



Berenson TM

Cabinet & Furniture Hardware



CYCLONE RANGE HOOD INSERTS

CYCLONE RANGE HOOD INSERTS

REAP THE BENEFITS

Did you know Berenson provides range hood inserts for a variety of applications? For over a decade, we have been a proud partner of Cyclone, a family-owned and Canadian operated business specializing in range hoods. Whether you're a cabinet manufacturer, dealer or homeowner, everyone benefits with Cyclone inserts, from showroom sales and cabinet production to installation and aftercare service.

TAKE CONTROL AND BUILD VALUE

Specification switches, botched installations, poor profit margins and nonexistent aftercare service are just a few of the costly challenges that can arise from homeowner sourced range hoods. By specifying Cyclone inserts early in your projects you can take full control of the range hood process to generate revenue, standardize hood manufacturing, and offer homeowners and your business first-class aftercare service. It's a simple, reliable and profitable solution.

FIRST CLASS WARRANTY & AFTERCARE SERVICE

Getting appliances serviced can be a headache inducing experience. In partnership with Cyclone, we proudly offer the best range hood warranty in the business. On top of it all, we can guarantee the fastest turnarounds on inspections, part replacements and aftercare service. You can depend on Berenson and Cyclone's high-quality products and first-class customer service to keep homeowners happy, and most importantly, healthy.

THE WARRANTY

- 2 years free parts and free in-home service
- 3rd year free parts and free in-store service
- Motors are covered for 10 years



All Cyclone range hoods have been tested and certified to meet CSA qualifications in Canada and the US



THE MODELS AT A GLANCE



BX600



BX215



BXB609/12

FEATURES & BENEFITS

- A range of CFM options for a variety of cooking applications.
- Inserts cannot be seen at eye level. Your hood design takes the spotlight!
- Built with 304 stainless steel, providing a sleek look with maximum durability.
- Bright, long-lasting lights illuminate the cooking area.
- Convenient, easy to access 3-speed fan controls.
- Multiple fan speeds save energy on lower ventilation settings.
- Baffle filters are dishwasher safe and easy for homeowners to maintain.
- Mesh filters efficiently purify the air while being simple to hand wash.
- Delay-off timers keep the fan running to continuously purify the air after cooking.
- A variety of insert sizes for different range and hood dimensions.
- Grease cups included on some models for safe and easy disposal of grease.

Item ID	Size	Cabinet Size	CFM	Duct Size	Noise Level	Lighting	Filter Type	Timer	Grease Cup
BX21528	28"	30"	550	6"	2-6 Sones	Halogen x2	Mesh	No	Yes
BX21534	34"	36"	550	6"	2-6 Sones	Halogen x2	Mesh	No	Yes
BX60028	28"	30"	600	6"	2-6 Sones	LED x2	Baffle	Yes	Yes
BX60034	34"	36"	600	6"	2-6 Sones	LED x2	Baffle	Yes	Yes
BXB60934	34"	36"	900	8"	2-10 Sones	LED x3	Baffle	Yes	No
BXB60940	40"	42"	900	8"	2-10 Sones	LED x3	Baffle	Yes	No
BXB60946	46"	48"	900	8"	2-10 Sones	LED x3	Baffle	Yes	No
BXB61234	34"	36"	1200	8"	2-14 Sones	LED x3	Baffle	Yes	No
BXB61240	40"	42"	1200	8"	2-14 Sones	LED x3	Baffle	Yes	No
BXB61246	46"	48"	1200	8"	2-14 Sones	LED x3	Baffle	Yes	No

BX600 | CLASSIC Collection



- Powered at 600 CFM, ideal for high-heat cooking on standard gas and electric ranges.
- Specialized angled baffle filters maximize ventilation and captured air.
- Delay-off timer keeps the fan running to continuously purify the air after cooking.
- Baffle filters are dishwasher safe, making them easy for homeowners to maintain.
- Grease cup included for safe and easy disposal of grease.

GREEN FEATURES



3 Speed Push Button Control Panel



Dishwasher Safe Baffle Filters



Long-lasting LED Light Bulbs



Grease Cup



Item ID	Size	Cabinet	CFM	Duct	Noise	Lights	Filters	Timer
BX60028	28"	30"	600	6"	2-6 Sones	LED x2	Baffle	Yes
BX60034	34"	36"	600	6"	2-6 Sones	LED x2	Baffle	Yes

Dimensions & Specifications

FEATURES

- 6" round duct adapter
- Non-stick aluminum fan blades
- 3 speed push button control
- Quick release dishwasher-safe baffle filters
- 2 LED light bulbs (2 x 1.4W GU10, 3000K)
- 3 minutes time-delay OFF feature
- Plug-in connection

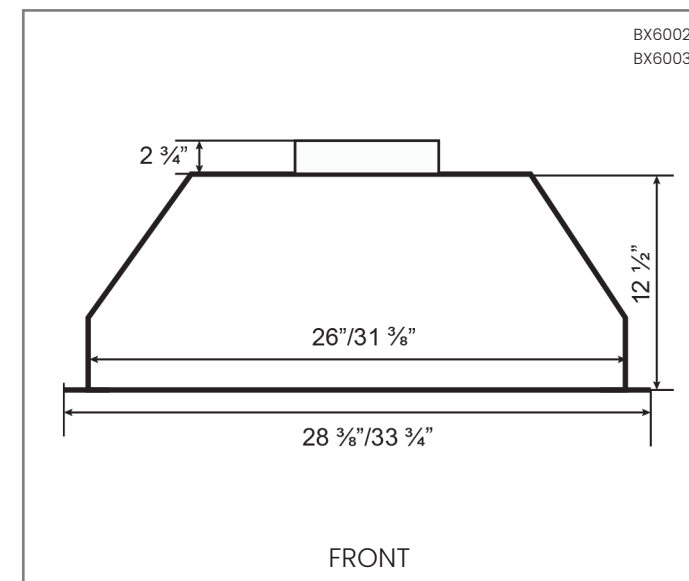
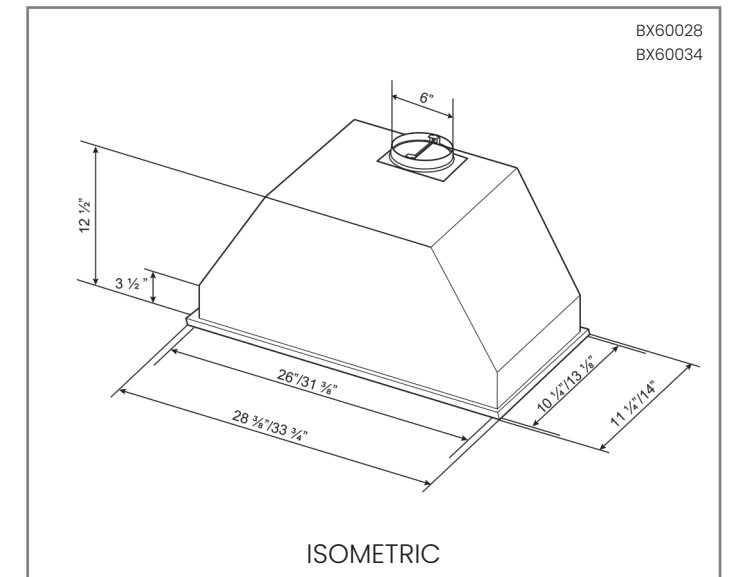

OPTIONS

- Widths: 28", 34"

SPECIFICATIONS

- Air Flow Volume: 600 CFM
- Electrical Connection: 120 V/60 Hz
- Power Consumption: 240 Watts
- Current: 2.0 Amps
- Fan Speed: 1599 RPM
- Fan Type: Centrifugal Blower
- Finishes: Stainless Steel
- Ducting: 6" Round
- Noise Level: Min. 2 Sones
Min. 6 Sones

For installation instructions, hood cutout dimensions, use and care guides, and detailed warranty information, please find these items on www.Berenson.ca

BXB609 | PRO Collection



- Powered at 900 CFM, ideal for high-heat cooking on large gas and electric ranges.
- Delay-off timer keeps the fan running to continuously purify the air after cooking.
- Baffle filters are dishwasher safe, making them easy for homeowners to maintain.

* May require installation with a make-up air kit or device. Please check your local building code or consult an HVAC professional.

GREEN FEATURES



3 Speed Push Button Control Panel



Dishwasher Safe Baffle Filters



Long-lasting LED Light Bulbs



Item ID	Size	Cabinet	CFM	Duct	Noise	Lights	Filters	Timer
BXB60934	34"	36"	900	8"	2-10 Sones	LED x3	Baffle	Yes
BXB60940	40"	42"	900	8"	2-10 Sones	LED x3	Baffle	Yes
BXB60946	46"	48"	900	8"	2-10 Sones	LED x3	Baffle	Yes

Dimensions & Specifications

FEATURES

- 8" round duct adapter
- Non-stick aluminum fan blades
- 3 speed push button control
- Quick release dishwasher-safe baffle filters
- 3 LED lights (x 1.4W, 4000K)
- 3 minutes time-delay OFF feature
- Plug-in connection

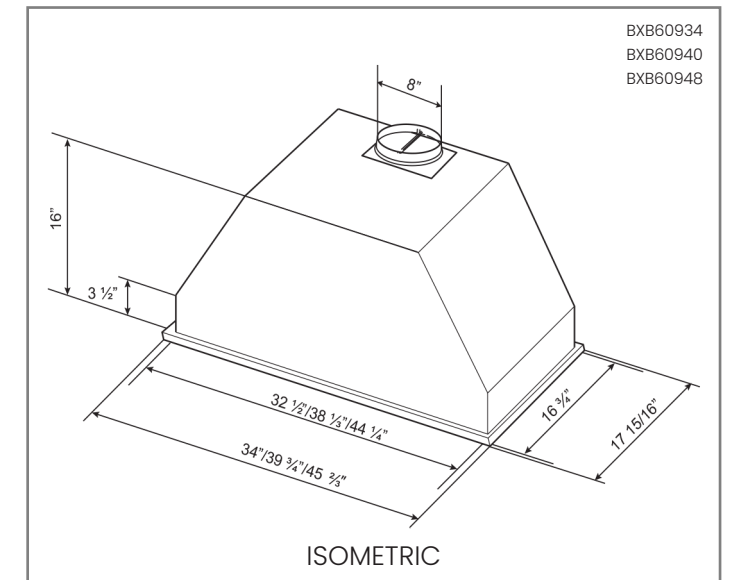

BXB60934
BXB60940
BXB60948

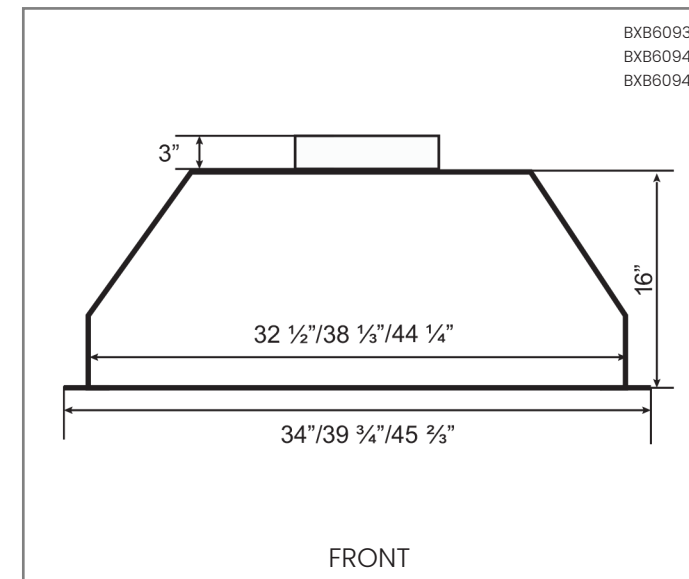

BXB60934
BXB60940
BXB60948

OPTIONS

- Widths: 34", 40", 46"

SPECIFICATIONS

- Air Flow Volume: 900 CFM
- Electrical Connection: 120 V/60 Hz
- Fan Type: Centrifugal Blower
- Finishes: Stainless Steel
- Ducting: 8" Round
- Noise Level: Min. 2 Max. 10

For installation instructions, hood cutout dimensions, use and care guides, and detailed warranty information, please find these items on www.Berenson.ca

BXB612 | PRO Collection



- Powered at 1200 CFM, ideal for multi-burner high-heat cooking on large gas and electric ranges.
- Delay-off timer keeps the fan running to continuously purify the air after cooking.
- Baffle filters are dishwasher safe, making them easy for homeowners to maintain.

* May require installation with a make-up air kit or device. Please check your local building code or consult an HVAC professional.

GREEN FEATURES



3 Speed Push Button Control Panel



Dishwasher Safe Baffle Filters



Long-Lasting LED Light Bulbs



Item ID	Size	Cabinet	CFM	Duct	Noise	Lights	Filters	Timer
BXB61234	34"	36"	1200	8"	2-14 Sones	LED x3	Baffle	Yes
BXB61240	40"	42"	1200	8"	2-14 Sones	LED x3	Baffle	Yes
BXB61246	46"	48"	1200	8"	2-14 Sones	LED x3	Baffle	Yes

Dimensions & Specifications

FEATURES

- 8" round duct adapter
- Non-stick aluminum fan blades
- 3 speed push button control
- Quick release dishwasher-safe baffle filters
- 3 LED lights (3 x 1.4W, 4000K)
- 3 minutes time-delay OFF feature
- Plug-in connection

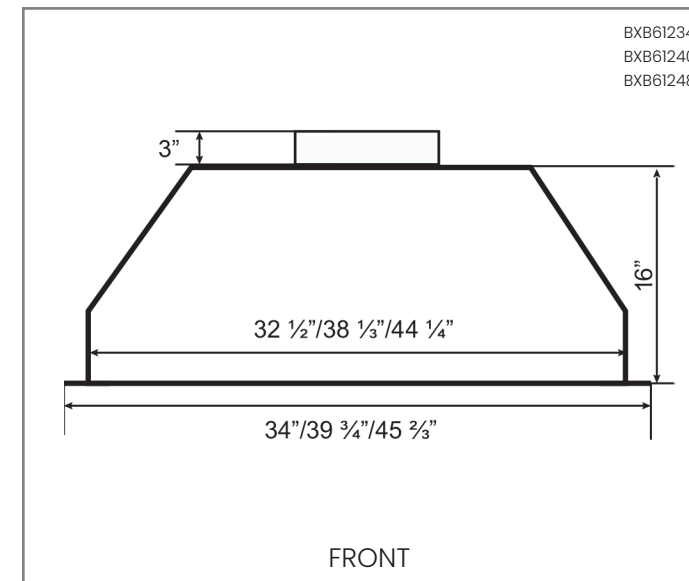
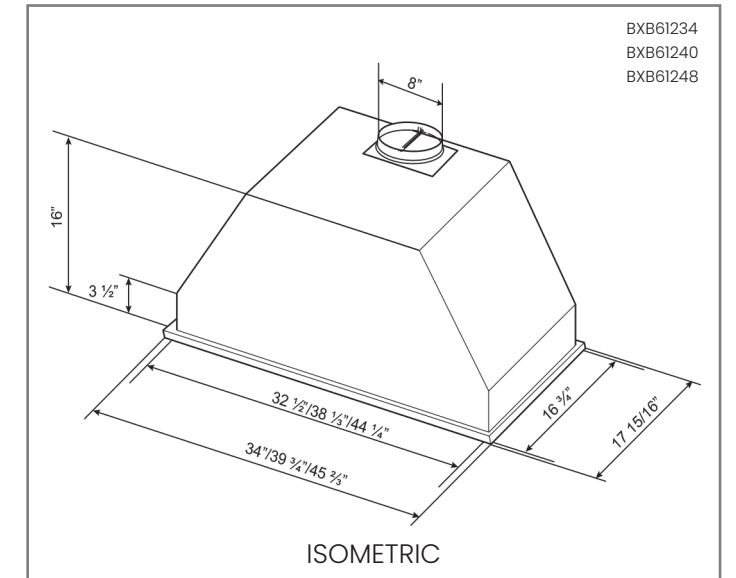

OPTIONS

- Widths: 34", 40", 46"

SPECIFICATIONS

- Air Flow Volume: 1200 CFM
- Electrical Connection: 120 V/60 Hz
- Fan Type: Centrifugal Blower
- Finishes: Stainless Steel
- Ducting: 8" Round
- Noise Level: Min. 2 Max. 14

For installation instructions, hood cutout dimensions, use and care guides, and detailed warranty information, please find these items on www.Berenson.ca

BX215 | CLASSIC Collection



- Powered at 550 CFM, ideal for high-heat cooking on standard electric ranges.
- Mesh filters efficiently purify the air while being simple to hand wash.
- Grease cup included for safe and easy disposal of grease.

GREEN FEATURES

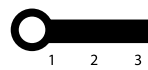

3 Speed Slide Control Panel



Grease Cup



Long-lasting Halogen Light Bulbs



Item ID	Size	Cabinet	CFM	Duct	Noise	Lights	Filters	Timer
BX21528	28"	30"	550	6"	2-6 Sones	Halogen x2	Mesh	No
BX21534	34"	36"	550	6"	2-6 Sones	Halogen x2	Mesh	No

Dimensions & Specifications

FEATURES

- 6" round duct adapter
- Non-stick aluminum fan blades
- 3 speed slide control
- Quick release aluminum mesh filters
- 2 halogen lights bulbs (2 x 25W E26)
- Plug-in connection

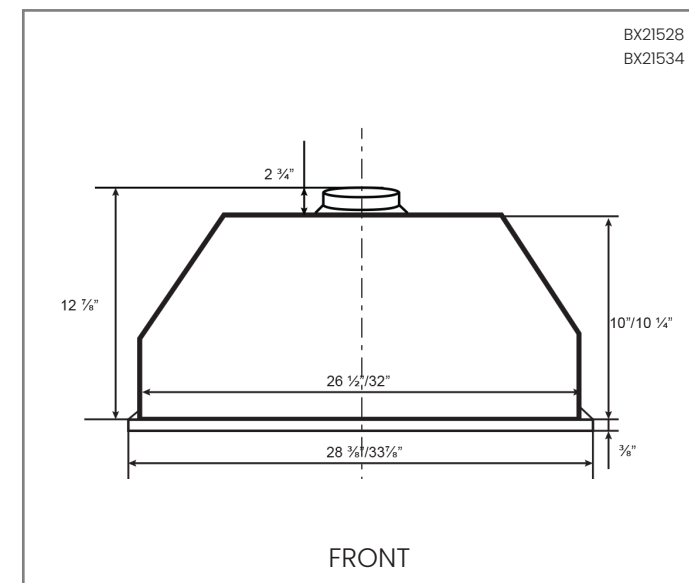
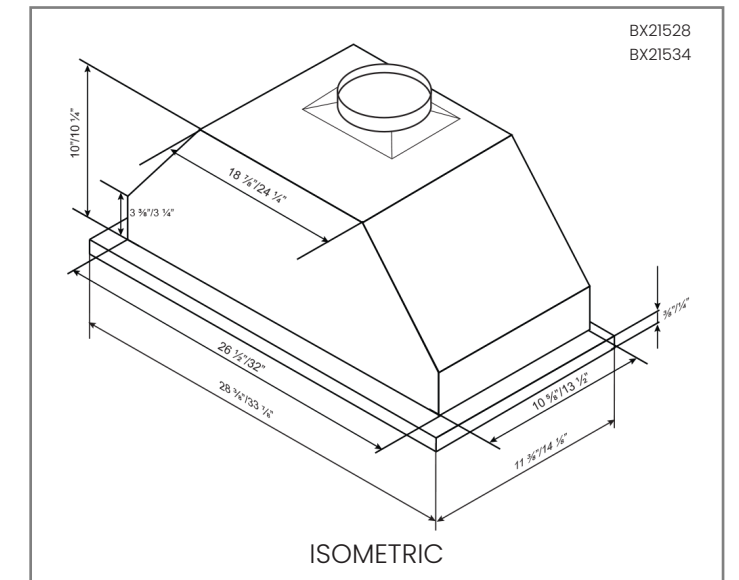

OPTIONS

- Widths: 28", 34"

SPECIFICATIONS

- Air Flow Volume: 550 CFM
- Electrical Connection: 120 V/60 Hz
- Power Consumption: 240 Watts
- Current: 2.0 Amps
- Fan Speed: 1599 RPM
- Fan Type: Centrifugal Blower
- Finishes: Stainless Steel
- Ducting: 6" Round
- Noise Level: Min. 2 Sones
Min. 6 Sones

For installation instructions, hood cutout dimensions, use and care guides, and detailed warranty information, please find these items on www.Berenson.ca



 **Berenson**  TM
Cabinet & Furniture Hardware

321 Hanlan Rd #1, Woodbridge, ON L4L 3R7
Phone: 800-268-0578 | Fax: 905-264-0360
Email: orders@berenson.ca
www.Berenson.ca



Look for Berenson Hardware Canada on Facebook, Instagram, LinkedIn, Pinterest, Tiktok, and Youtube

2024 Berenson Inc.