

***SALICE***





---

Dear Customer,

many years of work and experience have strengthened our presence on the market at the customers' service. This encourages us to improve and progress to win your confidence.

We hope that this new catalogue will contribute to facilitating our co-operation and developing our relationship; the knowledge of your requirements is at the base of our constant research and innovation.

Arturo Salice S.p.A.



**SALICE**

## The History



Salice workshop, end of the fifties  
Packing of products to be shipped

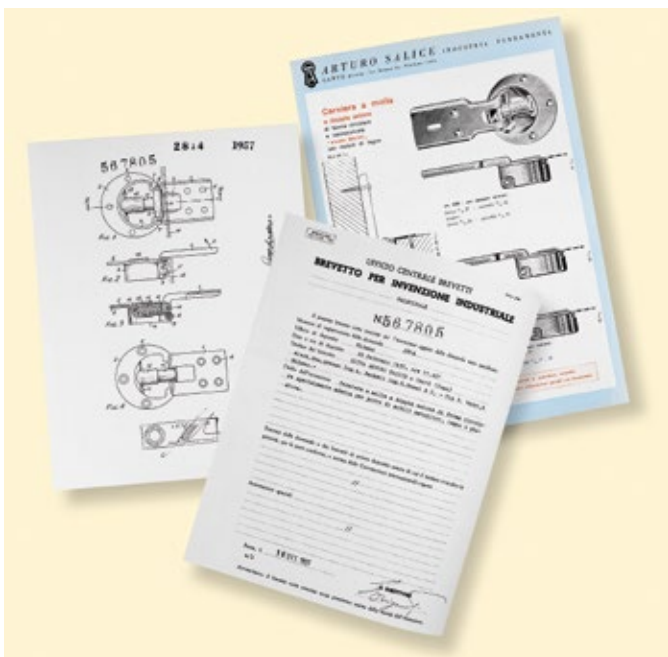

At the end of the fifties, the first factory is built in Cantù. Mr Arturo Salice starts the production of his own line of furniture hardware. His sons Giorgio and Luciano enter the company, supporting their father in the management and in upholding the typical values of the Lombard industrial tradition. On the 22nd February 1957 Salice registers the first patent covering a concealed, cylindrical and self-closing hinge for furniture; an authentic milestone of innovation and technology for the whole sector.

Thus Arturo Salice S.p.A. was born.



Salice, leader in the field of concealed hinges and accessories for furniture, produces a wide range of high quality products meant for industries specialized in the field of kitchen cabinets and furniture in general.

With 400 employees and 8 subsidiaries, Salice exports 65% of production to over 80 countries worldwide.

Its history begins in 1926 when Arturo Salice starts in Cantù, Como province, a trade activity for the retail distribution of furniture hardware produced in Italy or imported from foreign countries.

The activity, initially confined to the local area, soon extends to the whole of Italy.

Arturo Salice, end of the fifties



The rapid development of the company and the success that the Salice products achieve, both in Italy and abroad, require the construction of new production facilities.

In 1975, in Novedrate, on a 240.000 m<sup>2</sup> area the new factory is inaugurated, which is gradually enlarged and completed: today the built area covers 60.000 m<sup>2</sup>.

Since the year 2000 the company ADAR S.p.A., now known as SALICE GUIDE S.p.A., specialized in the production of runners and metal drawers and since 2010 the company BORTOLUZZI SISTEMI S.p.A., specialized in the production of sliding door systems, complete the wide range of products.

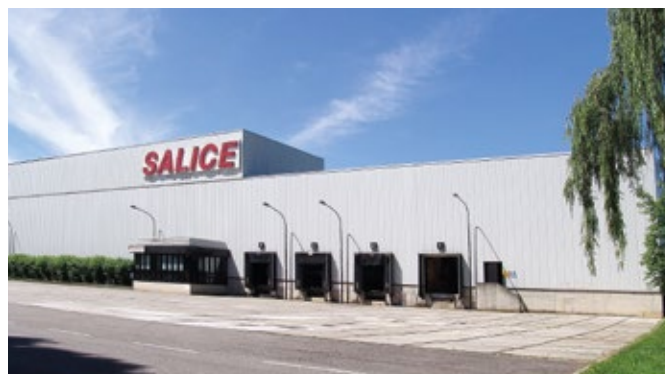



Deutsche Salice, Neckarwestheim founded in 1971



### The Subsidiaries

Salice is active in all the industrialized countries of the world through a network of exclusive distributors and agents. The sales and distribution functions are assisted by subsidiaries all over the world. In 1971 open the first two branches in Neckarwestheim, Germany and in Antibes, France. Meanwhile the company continues its evolution and in 1985 open the third branch in Huntingdon, England; between 1988 and 1989 Salice arrives in Mississauga, Canada and in Charlotte, United States. In 1993, in order to better support the German and American market, Salice decides to strengthen the services offered and open the branches in Löhne and in Los Angeles. Also in the Iberian peninsula Salice consolidates its presence in 2011 with the opening of Salice España in Barcelona.

Salice France founded in 1971



Salice UK founded in 1985



Salice Canada founded in 1988



Salice America, Charlotte founded in 1989



Deutsche Salice, Löhne founded in 1993



Salice America, Los Angeles founded in 1993



Salice España, founded in 2011



### The Certifications

To the certification obtained by Salice in 1993 for its “QUALITY MANAGEMENT SYSTEM ISO 9001”, in 1998 one for the “ENVIRONMENTAL MANAGEMENT SYSTEM ISO 14001” is added, to witness that the company is absolutely compliant with the laws that guarantee the safeguard of the environment. The certifications issued at the end of verifications, which Salice voluntarily underwent, guarantee its compliance to the rules set by the International Organization for Standardisation (ISO) and by the European Committee for Standardisation (CEN). The certification body chosen by Salice is DNV-Det Norske Veritas, a Norwegian control organisation founded in 1864 and internationally known for its professionalism and competence.





Salice Technological Centre in the Novedrate factory

## The Research

A team of highly qualified technicians is constantly seeking new and always more sophisticated products which must meet the demands of the markets with high-precision and high-quality technical and technological solutions.



Technological Centre: Research and Development



Technological Centre: Technical Office

## The Tooling Department

It operates inside the Technological Centre. In this department, the production equipment, tooling and assembly machines, resulting from the continual researches and computerized design of the Technical Office, are produced.

This enables the company to promptly respond to the customers' requests and to offer the market always innovative and quality products.

The close link between this department and the production cycle enables Salice to produce in large quantities, with the highest possible degree of automation, keeping the total and constant control over the quality standards.



## The Production

In 1957 Salice decides to concentrate all its energies on a single type of product: concealed hinges for furniture and relative accessories. This well-founded decision has allowed Salice to reach a high level of specialisation, supported by a policy of investments directed at innovation and rationalisation of production processes. The production cycle, on three shifts, is assured by workmanship of proven ability and competence. These characteristics have deservedly earned Salice the reputation of being the reliable and safe partner of the most prestigious furniture companies.

## The Logistics

All production phases, assemblies, movements and deliveries are assisted by computerized systems which assure the correct course of every single operation, thus guaranteeing the fast execution of the orders, correct management of the shipments and punctual deliveries. A further cornerstone of service to the customers.



## Customer Service

Salice primary goals are innovation, quality and customer service, to which Salice reserves the greatest attention. With the customer, Salice wishes to establish a close relationship of mutual collaboration. Every technical problem raised by the customer, existing or potential, is examined and evaluated by the experts of the Technical Office: a team of specialists who avail themselves of a C.A.D. system that integrates and assists the Research and Development department, analyses the problem and promptly solves it.



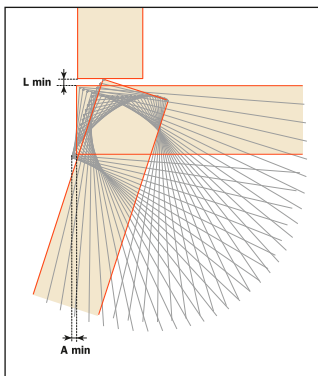

**Abbreviations**

page 11

**Explanatory notes and assembly instructions**

page 12

**Sideways adjustment**

page 14

**Depth adjustment**

page 15

**Height adjustment**

page 17



**Silentia**

*Hinges with integrated  
Soft-close*

Series 100  
Series 200 for thicker doors  
For metal profiles  
Series 700  
Series 800  
Series 900

page 20  
page 28  
page 40  
page 46  
page 60  
page 66



**Series 100**

*Hinges for doors with  
a minimum thickness  
of 10 mm*

Technical features  
105° opening  
155° opening  
Complementary hinges:  
for wooden doors with positive angled assembly  
crampon hinges

page 72  
page 74  
page 76  
page 78  
page 80



**Series 200**

Technical features  
94° opening for thicker doors  
110° opening  
120° opening  
155° opening  
155° opening for thicker doors  
165° opening  
Complementary hinges:  
for glass doors  
for glass doors with positive angled assembly  
crampon hinges for glass doors  
for fridge doors  
for wooden doors with positive angled assembly  
for wooden doors with negative angled assembly  
crampon hinges  
for corner cabinets  
Special angled assemblies

page 82  
page 84  
page 86  
page 88  
page 90  
page 92  
page 96  
page 98  
page 100  
page 100  
page 101  
page 102  
page 104  
page 105  
page 108  
page 110



**Series F**

*Hinges with cup diameter  
40 mm, for thicker doors  
and doors with moulded  
profiles*

Technical features  
94° opening  
Assembly examples

page 112  
page 114  
page 116

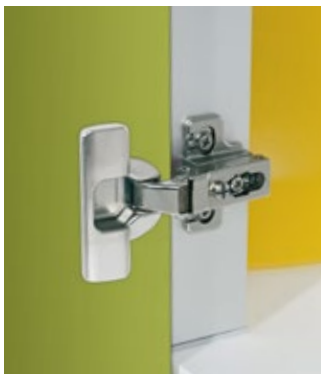

**Series 300**  
*Hinges with small operating profile*

Technical features  
94° opening

page 118  
page 120



**Series 800**

Technical features  
110° opening

page 124  
page 126



**Series 900**

Technical features  
94° opening  
110° opening

page 130  
page 132  
page 134



**For metal profiles**

Practical System  
Accessories for the frame assembly  
Assembly instructions  
Series 200  
Series 400

page 138  
page 142  
page 143  
page 144  
page 148



**Mini hinges**  
*Hinges with cup diameter 26 mm*

**Series 400**  
Technical features  
94° opening  
Complementary hinges:  
for wooden doors with angled assembly  
crampon hinges  
**Series 600**  
Technical features  
94° opening  
Complementary hinges:  
for wooden doors with positive angled assembly  
crampon hinges  
for glass doors  
for glass doors with positive angled assembly  
crampon hinges for glass doors

page 152  
page 154  
page 156  
page 156  
page 158  
page 160  
page 162  
page 163  
page 164  
page 165  
page 165



**Serie B**  
Hinges that need to be bonded to glass

**For glass doors**  
Technical features  
110° opening

page 168

page 169

**Serie B**  
Hinges for half-inset doors or doors with moulded profiles

**For wooden doors**  
Technical features  
110° opening  
Assembly examples

page 170  
page 172  
page 174



**Series M**  
Single pivot hinges

Technical features  
270° opening  
Assembly examples

page 178  
page 179  
page 180

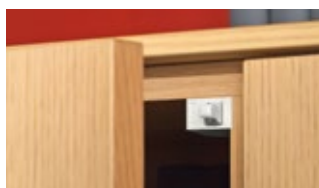

**Push**  
Push to open system for handle-less doors

**Mechanical Push**  
Retaining catches for wooden doors  
Retaining catches for aluminium-frame doors  
Adapters  
Spacers and insertion tool for retaining catch  
Assembly instructions and drillings

page 185  
page 188  
page 189  
page 190  
page 191  
page 192

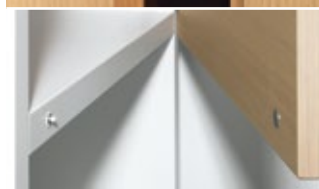

**Magnetic Push**  
Release devices and retaining catches  
Adapters  
Assembly instructions

page 198  
page 199  
page 200

**Push hinges**  
Series 200 hinges  
Hinges for metal profiles  
Series B hinges

page 206  
page 222  
page 230



**Domi snap-on mounting plates**

page 238



**Series 200 mounting plates with traditional assembly**

page 242





## Series 300 mounting plates

page 250



## Smove

*Soft-Close systems for doors*

### Adjustable

D0S\_SNG  
D0L\_SNG and D0L\_SNGR

page 252

page 258

### To be recessed

D005SN  
D006SN  
D008SN  
D009SN  
D010SN

page 262

page 263

page 264

page 265

page 266

### Adapters

page 268



## Sliding system for concertina doors

Technical features  
Elements of the system  
Adjustments  
Assembly instructions  
Packaging and code number

page 276

page 277

page 278

page 280

page 283



## Lift - Opening systems

Flap door  
Folding door  
Parallel opening door for doors  
from 360 mm to 440 mm height  
Parallel opening door for doors  
from 440 mm to 660 mm height  
Swing opening door

page 285

page 305

page 322

page 326

page 341



## Connecting fitting

page 353



## Accessories

Screw cover caps	page 358
Flange cover caps	page 359
Spacers, gange and fancy cover for Silentia hinges	page 359
Fancy covers for glassdoor hinge cup	page 360
Spacers for Series 200, F and 600 hinges	page 361
Stop devices	page 362

# Abbreviations

Application with full overlay door

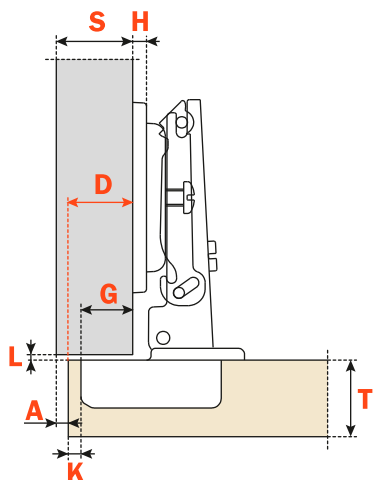

- S** = Thickness of the cabinet side
- D** = Required door overlay
- T** = Door thickness
- K** = Drilling distance
- A** = Reveal
- L** = Gap between door and carcass
- H** = Height of the mounting plate
- G** = Hinge constant

Whatever door overlay is required, you can select from our range the combination of both the type of hinge arm and the thickness of mounting plate necessary to solve your construction problem and avoid the need to stock too many different components.

Application with half overlay door

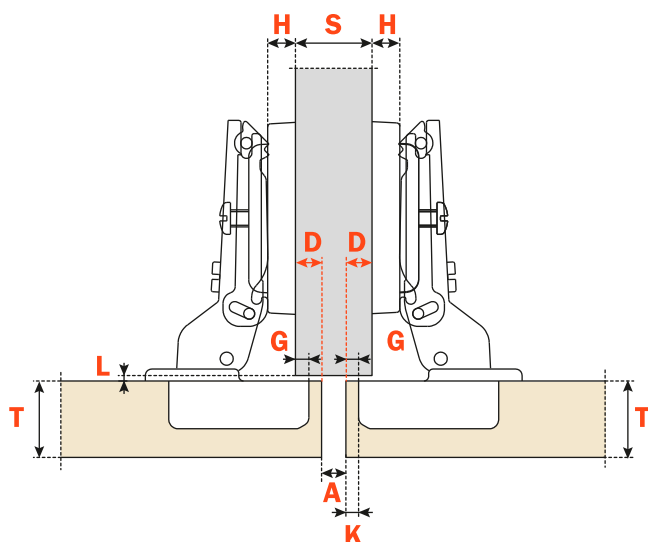

Application with inset door

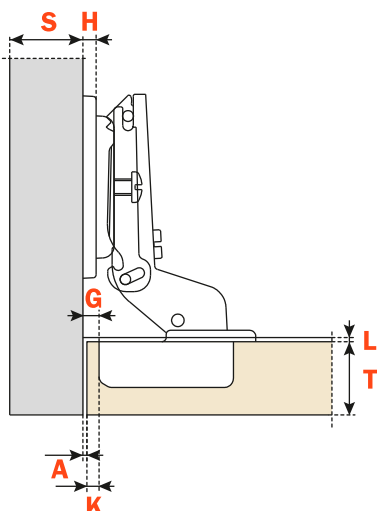

- S** = Thickness of the cabinet side
- T** = Door thickness
- K** = Drilling distance
- A** = Reveal
- L** = Gap between internal face of door and internal cabinet elements (e.g. shelves, drawers, etc.)
- H** = Height of the mounting plate
- G** = Hinge constant

Whatever door overlay is required, you can select from our range the combination of both the type of hinge arm and the thickness of mounting plate necessary to solve your construction problem and avoid the need to stock too many different components.

# Explanatory notes and assembly instructions

Simulation of the opening movement of a 110° hinge with full overlay door

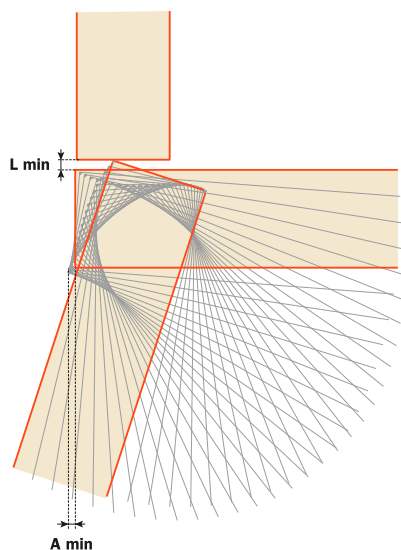

Simulation of the opening movement of a 110° hinge with half overlay door

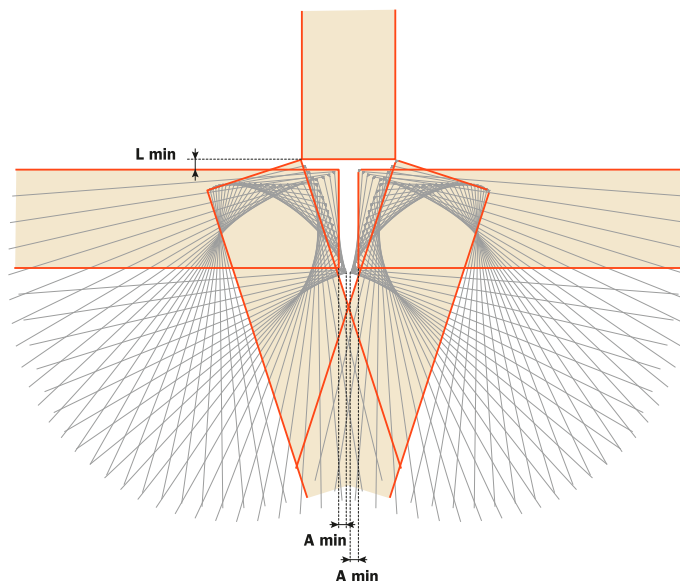

**For hinges Series 100, 200, F, 400, 600, B, M and Silentia**  
Traditional assembly with Series 200 mounting plates

Place the hinge onto the mounting plate. Push the hinge up to the pre-determined stop under the hinge arm.

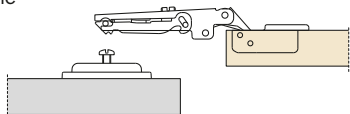

Tighten the fixing screw.

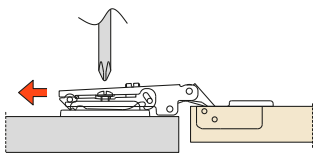

An "L" value of 0.7 mm between door and cabinet side is achieved on final assembly.

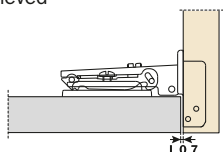

"Key hole" safety feature.

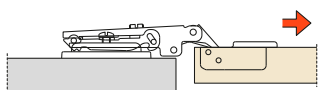

**For hinges Series 100, 200, F, 400, 600, B, M and Silentia**  
Assembly with Domi snap-on mounting plates

Locate the lugs on the mounting plate into the recesses beneath the arm.

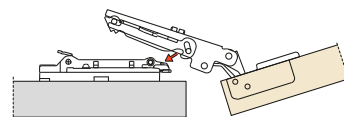

Gently rotate the door in the direction shown.

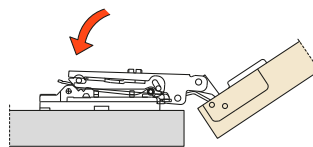

Then press lightly on the end of the arm to secure the catch.

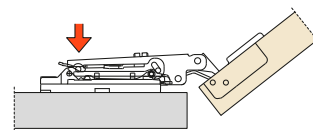

To remove the hinge from the mounting plate, press gently in the places shown by the arrows.

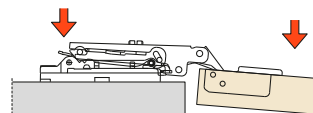

### For hinges Series 300

Traditional assembly with Series 300 mounting plates

Place the hinge onto the mounting plate. Push the hinge up to the pre-determined stop under the hinge arm.

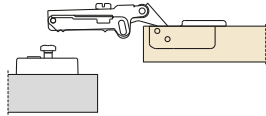

Tighten the fixing screw.

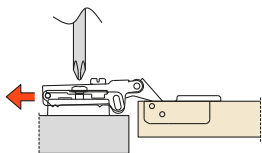

An "L" value of 0.7 mm between door and cabinet side is achieved on final assembly.

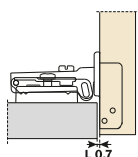

"Key hole" safety feature.

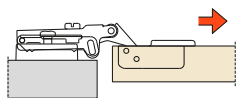

### For hinges Series 800

Assembly with Series 200 steel mounting plates

Locate the lugs on the mounting plate into the recesses beneath the arm.

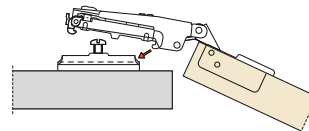

Gently rotate the door in the direction shown. Then press lightly on the end of the arm to secure the catch.

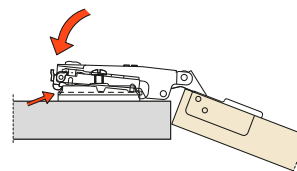

An "L" value of 0.7 mm between door and cabinet side is achieved on final assembly.

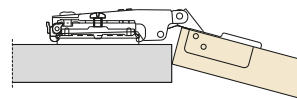

To remove the hinge from the mounting plate, press gently in the place shown by the arrows.

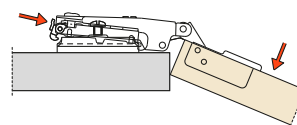

### For hinges Series 900

Traditional assembly with Series 200 mounting plates

Place the hinge onto the mounting plate. Push the hinge up to the pre-determined stop under the hinge arm.

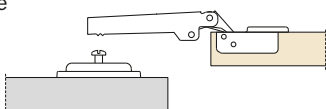

Tighten the fixing screw.

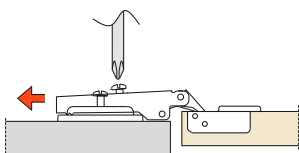

An "L" value of 0.7 mm between door and cabinet side is achieved on final assembly.

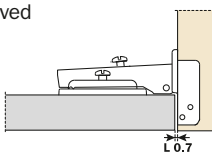

"Key hole" safety feature.

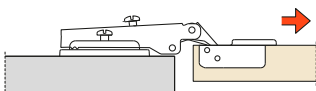

## Sideways adjustment of the door with Series 100, 200, 300, F, 400, B, M and Silentia hinges

A specially developed technical solution allows the sideways adjustment of the door while maintaining the gap behind the door ("L" value of 0.7 mm). The adjustment screw operates in conjunction with the inner leaf of the hinge arm. The door moves in only one direction - parallel to the carcass and without a gap developing between the door and the carcass. No further adjustments are necessary.

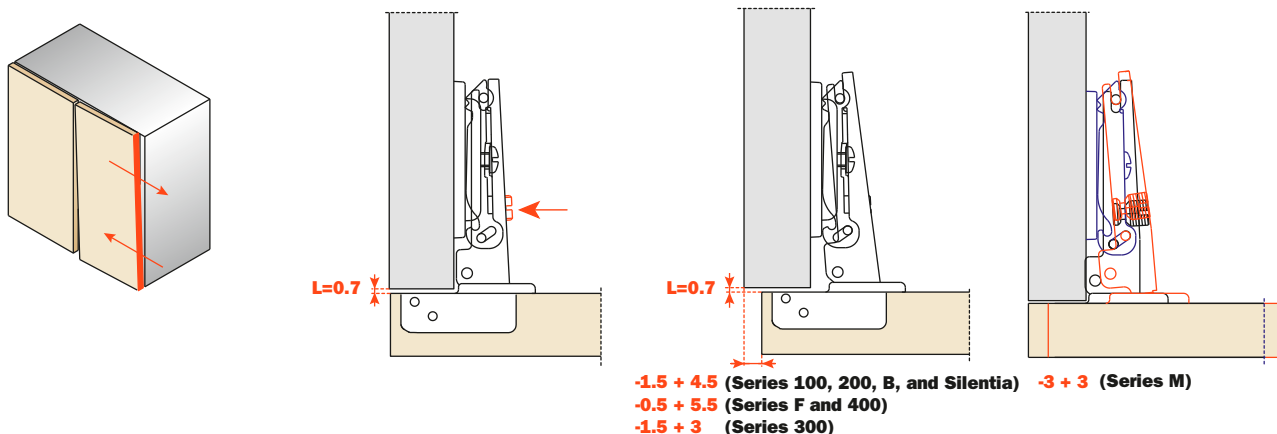

## Sideways adjustment of the door with Series 800 hinges and Silentia Series 800 hinges

Sideways adjustment of the door is made by using the indicated screw. It is possible to recover the gap behind the door (the initial "L" value of 0.7 mm) simply by using the assembly stop located on the underside of the hinge.

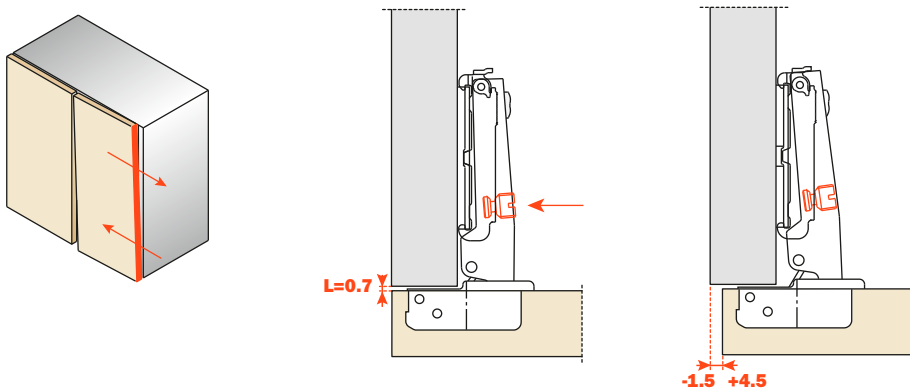

## Sideways adjustment of the door with Series 900 and 600 hinges and Silentia Series 900 hinges

Required sideways adjustment of the door is made by slackening the hinge fixing screw. It is possible to recover the gap behind the door (the initial "L" value 0.7 mm) simply by using the assembly stop located on the underside of the hinge. Finally the fixing screw must be retightened.

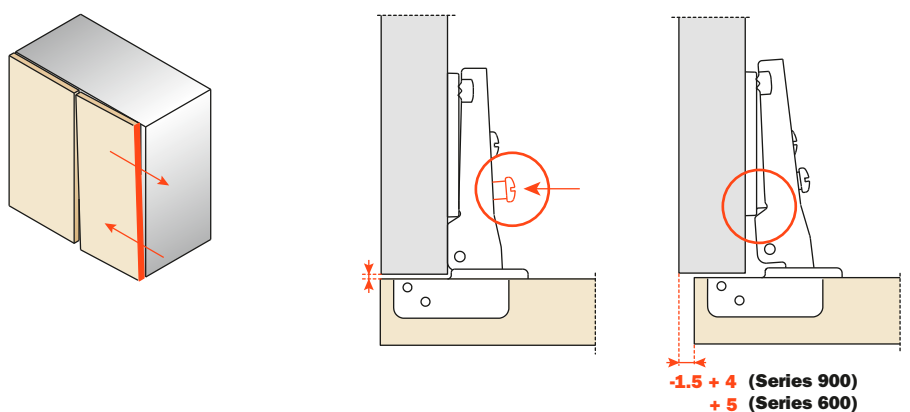

## Traditional depth adjustment

The hinge fixing screw is slacked and an oval slot on the arm of the hinge enables the door to be adjusted frontally by + 2.8 mm. Finally the fixing screw must be retightened.

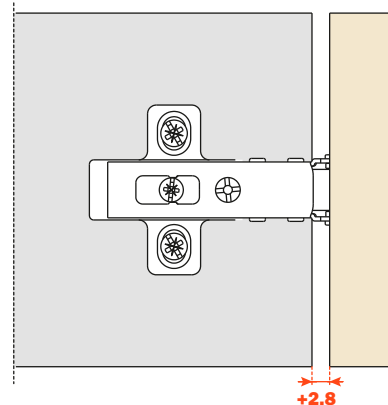
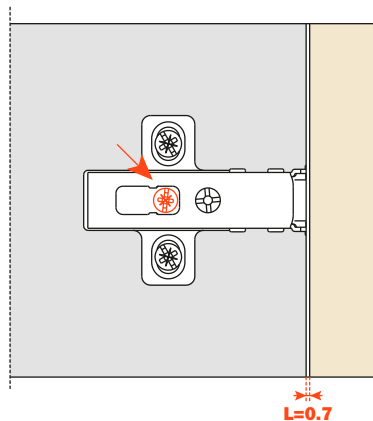
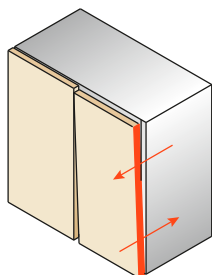

## Traditional depth adjustment with Series 800 hinges

The hinge fixing screw is slacked and an oval slot on the arm of the hinge enables the door to be adjusted frontally from -1.5 mm to +3 mm. Finally the fixing screw must be retightened.

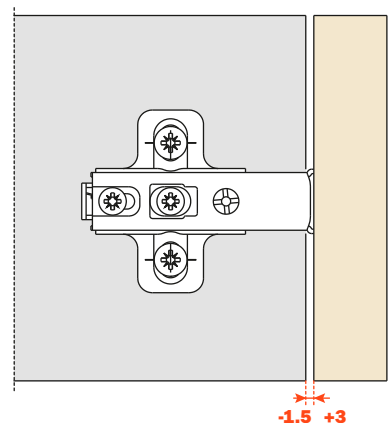
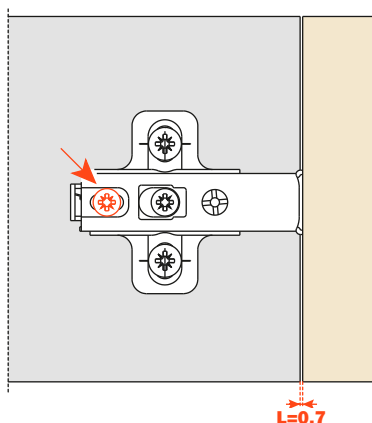
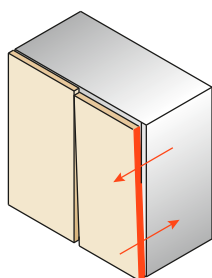

## Depth adjustment with Domi snap-on mounting plates - Model BAV

Depth adjustment is made without loosening any screws. The door can be moved frontally from -0.5 mm to +2.8 mm simply by rotating the cam adjuster in this range of mounting plates.

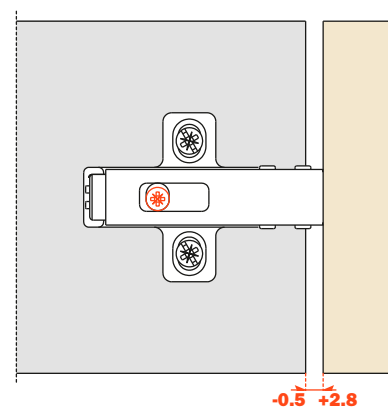
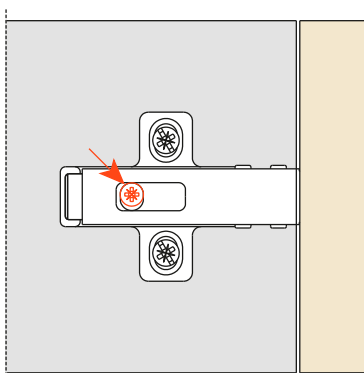
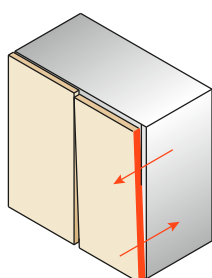

## Depth adjustment with Domi snap-on mounting plates - Models BAPXR and BARXR

Depth adjustment is made without loosening any screws. The door can be moved frontally from -0.5 mm to +2.8 mm simply by rotating the cam adjuster in this range of mounting plates.

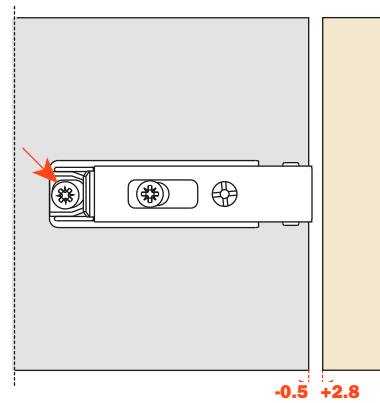
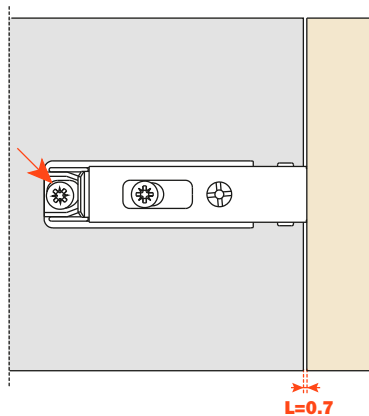
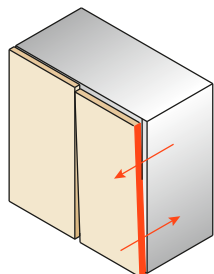



# Height adjustment

## Height adjustment with Domi snap-on mounting plates - Model BAV - Series 200

By loosening the two fixing screws it is possible to adjust the door vertically by  $\pm 2$  mm. The oval holes allow the mounting plate to slide freely in both directions. Finally, the screws must be retightened.

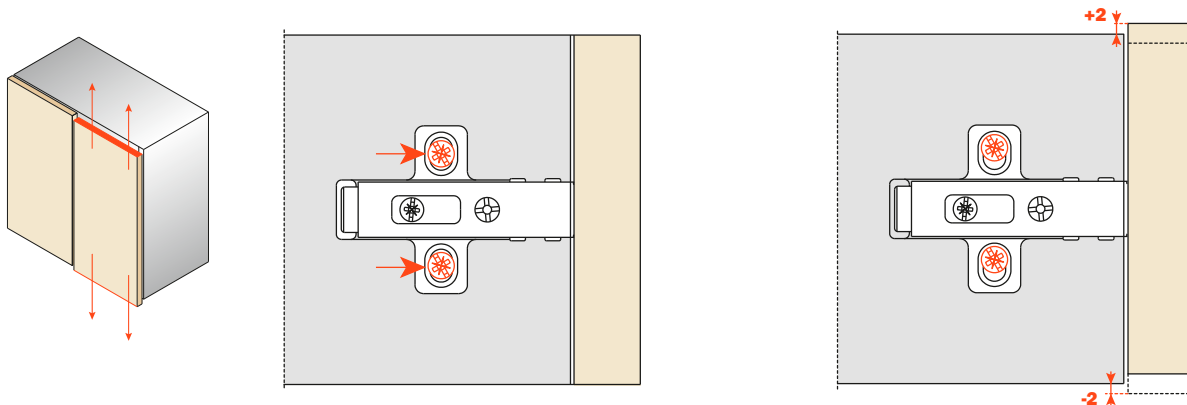

## Height adjustment with Series 200 mounting plates - Models B2RXE and B2PXE

Height adjustment is made without loosening any screws. The door can be moved vertically by  $\pm 2$  mm simply by rotating the cam adjuster in this range of mounting plates.

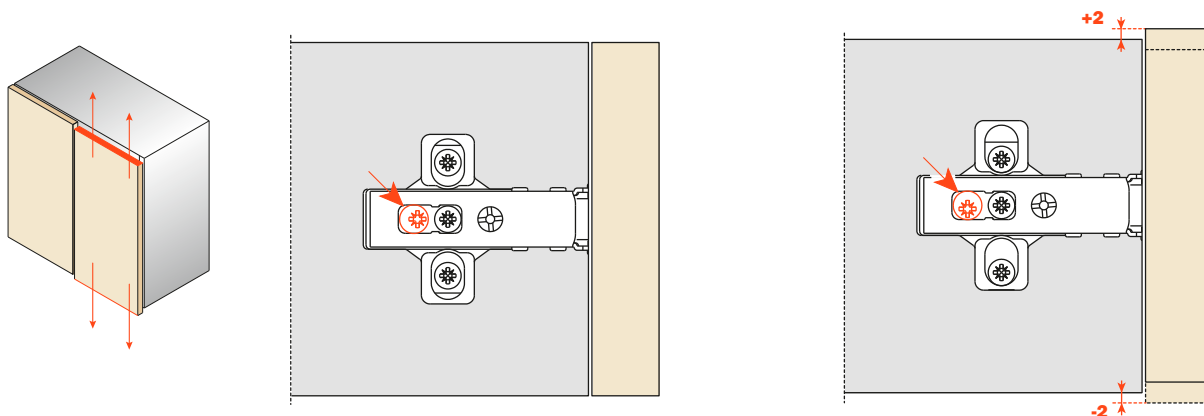

## Height adjustment with Domi snap-on mounting plates - Models BAPXR and BARXR

Height adjustment is made without loosening any screws. The door can be moved vertically by  $\pm 2$  mm simply by rotating the cam adjuster in this range of mounting plates.

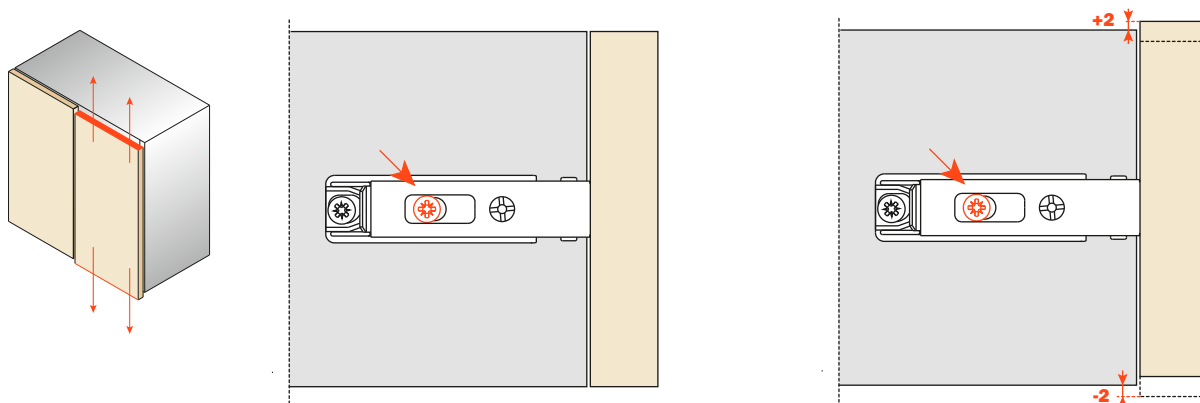



## Silentia - Series 100



Hinges with integrated soft-close mechanism in the hinge cup.

Bright nickel plated steel cup and arm.  
 Dimensions of the Ø 35 mm cup.  
 Hinges for doors of small weight and thickness.

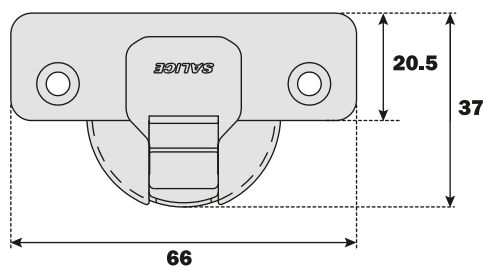

Constant "L" value of 0.7 mm (it does not change during side adjustment).

Approx. number of hinges required according to the door dimension and weight.

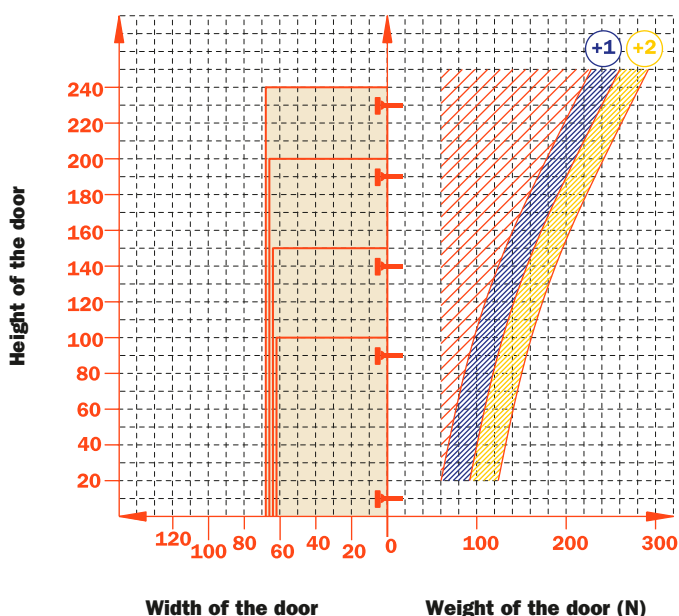





### Adjustments

Compensated side adjustment from -1.5 mm to +4.5 mm.  
 Height adjustment  $\pm 2$  mm.  
 Depth adjustment with Series 200 mounting plates +2.8 mm.  
 Depth adjustment with Domi snap-on mounting plates from -0.5 mm to +2.8 mm.  
 Anti-sliding safety stop.

### Mounting plates

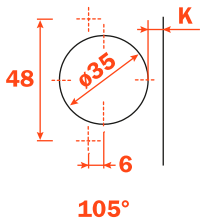
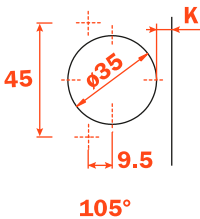
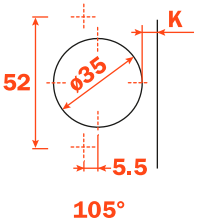
Symmetrical and asymmetrical bright nickel plated steel or die-cast Series 200 mounting plates.  
 Snap-on assembly on Domi mounting plates.  
 Positioning with pre-determined stop on traditional Series 200 mounting plates.

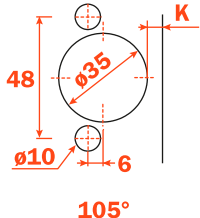
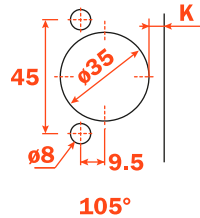
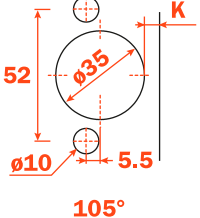
N.B. : Use POZIDRIVE No. 2 screwdrivers for all screws.

			
Wood screw 	A	P	U
			
Rapido 	6	7	2
Dowel 	B	R	W

Use this table to identify the available drillings and fixings.  
 Fill the third position of the hinge code number with the letter or the number corresponding to your choice. I.e.: C1\_6AD9.

↑  
 Fill this position with the chosen letter or number.

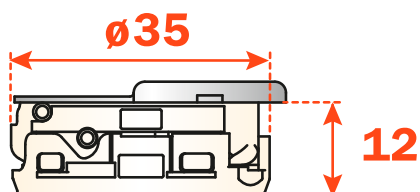

**105° opening  
 and complementary hinges**



**Attention:**  
 it is essential to drill the door as specified for  
 the perfect functioning of the hinge.



**Technical information**

**Hinges with integrated soft-close mechanism in the hinge cup.**

**Hinges for doors of small weight and thickness.  
12 mm deep cup.  
105° opening.**

Possible drilling distance on the door (K): from 3 to 6 mm.  
Compatible with all traditional Series 200 mounting plates and with all Domi snap-on mounting plates.

**Space needed to open the door**

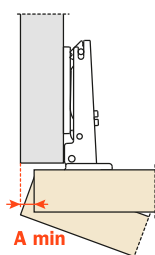

	T=	15	16	17	18	19	20
K=3	<b>A=</b>	1.0	1.0	1.2	1.4	1.6	1.9
K=4	<b>A=</b>	0.9	1.0	1.2	1.3	1.5	1.8
K=5	<b>A=</b>	0.9	1.0	1.1	1.2	1.5	1.8
K=6	<b>A=</b>	0.9	1.0	1.1	1.2	1.4	1.7

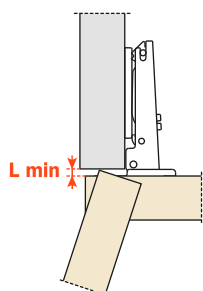

	T=	15	16	17	18	19	20
K=3	<b>L=</b>	0.0	0.0	0.0	0.0	0.1	0.3
K=4	<b>L=</b>	0.4	0.6	0.7	0.9	1.1	1.2
K=5	<b>L=</b>	1.0	1.0	1.2	1.8	2.0	2.0
K=6	<b>L=</b>	1.6	1.8	2.0	2.1	2.3	2.5

**The above values are calculated on the assumption that the doors have square edges. They are reduced if the doors have radiussed edges.**

**Projection of the door**

Projection of the door from the cabinet side at the max. opening. The figures are based on a straight arm hinge, H=0 mm thickness of mounting plate and K value = 3 mm.

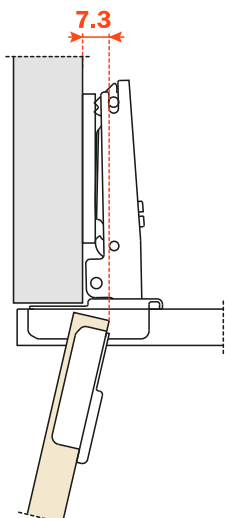

**“C” value**

With this formula you can obtain the max. thickness of the moulded door that can be opened without touching adjacent carcass sides, doors or walls, whilst bearing in mind the above L-K-T values.

$$C = 20.5 + K + A$$

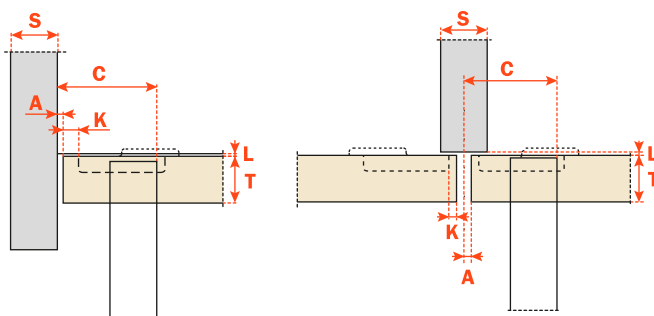

**Packing**

Boxes 300 pcs.  
Pallets 7.200 pcs.

Use these formulas to determine the type of hinge arm, the drilling distance "K" and the height of the mounting plate "H" which is necessary to solve each application problem.

Use the tables "Drillings and fixings" at page 21 to complete the code number of the desired hinge.

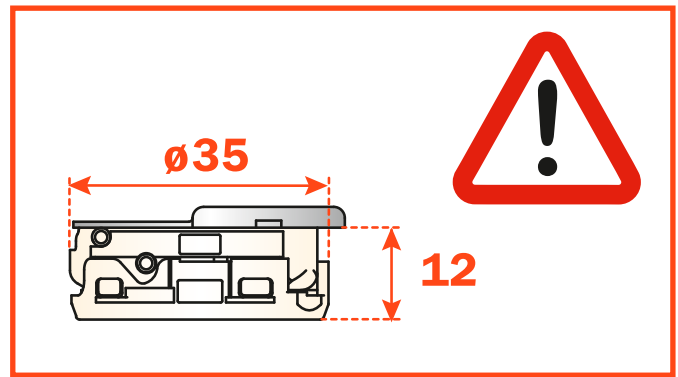
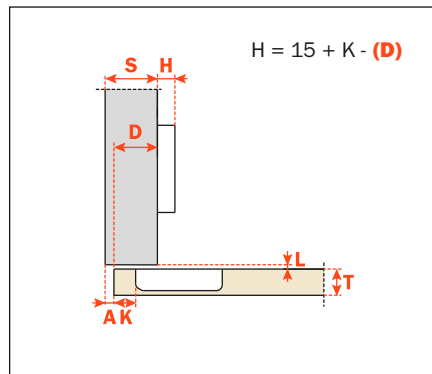
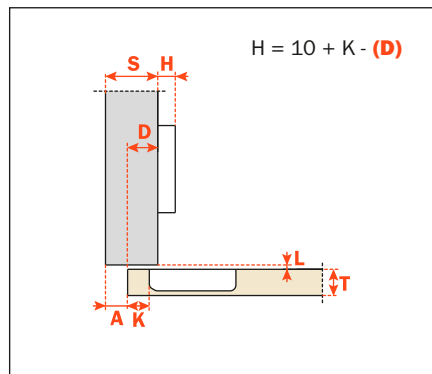
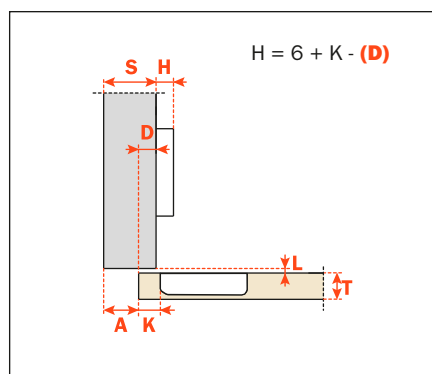
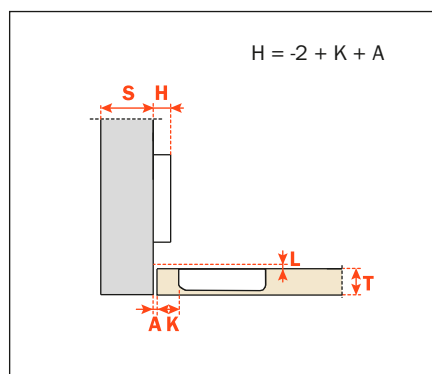
**Arm 0****C1\_6AD9****Arm 5****C1\_6DD9****Arm 9****C1\_6GD9****Arm 17****C1\_6PD9**



**Technical Information**

**Hinges with integrated soft-close mechanism in the hinge cup.**

**For wooden doors with positive angled assembly.  
Hinges for doors of small weight and thickness.  
12 mm deep cup.**

105° opening.

Possible drilling distance on the door (K): from 3 to 6 mm.

Compatible with all traditional Series 200 mounting plates and with all Domi snap-on mounting plates.

**Packing**

Boxes 150 pcs.

Pallets 3.600 pcs.

The solution of assembly problems where doors are mounted at a positive angle requires the verification of drilling distances by a practical trial. Please do not hesitate to consult our technical support department for assistance.

Use the tables "Drillings and fixings" at page 21 to complete the code number of the desired hinge.

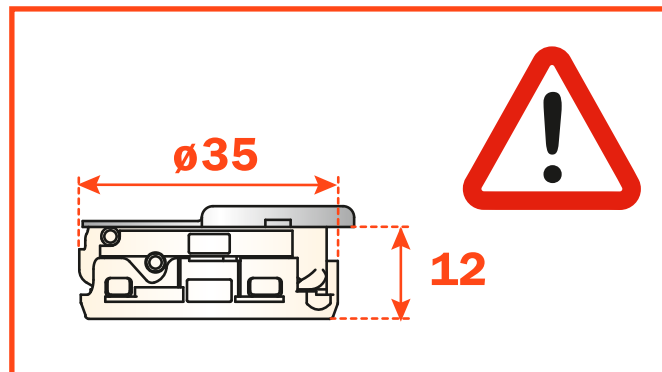

**Arm 15°**

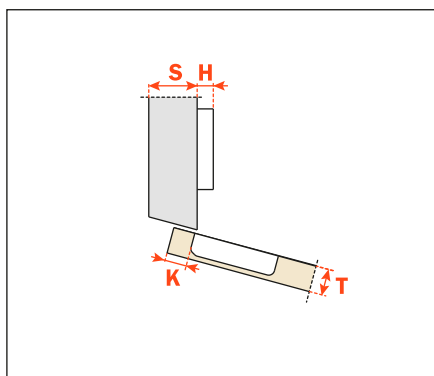

**C1\_6ZD9**

**Arm 24°**

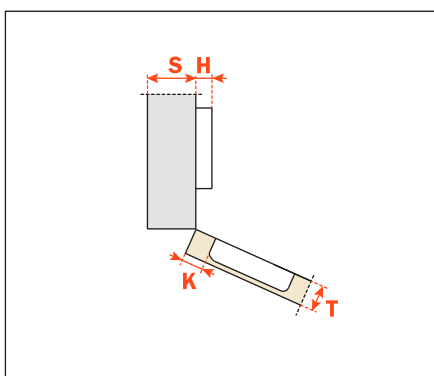

**C1\_6UD9**

**Arm 30°**

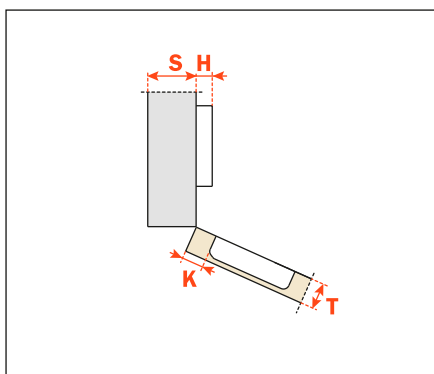

**C1\_6ED9**



Arm 30°

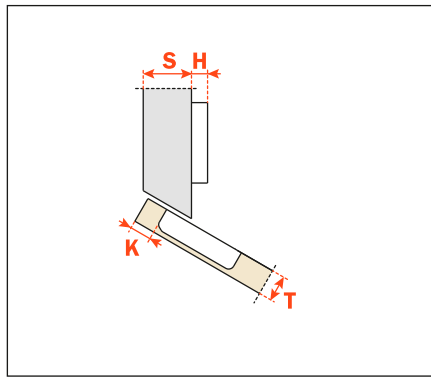

**C1\_6TD9**

Arm 37°

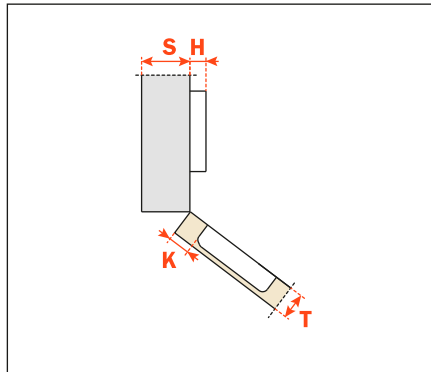

**C1\_6KD9**

Arm 45°

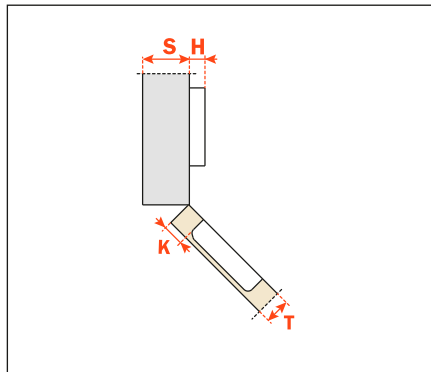

**C1\_6MD9**

Arm 45°

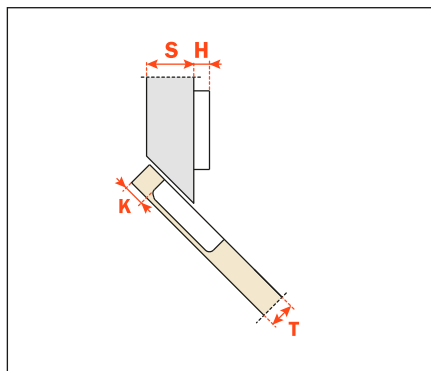

**C1\_6VD9**

Arm 45°

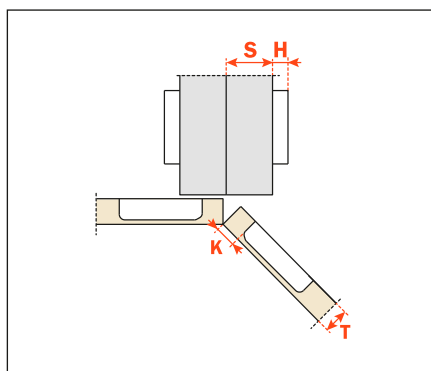

**C1\_6MD9AC**



**Technical Information**

**Hinges with integrated soft-close mechanism in the hinge cup.**

**Crampon hinges.**  
**For cabinet sides with 37x32 standard drilling.**  
**Hinges for doors of small weight and thickness.**  
**12 mm deep cup.**

105° opening.  
 Possible drilling distance on the door (K): from 3 to 6 mm.  
 Compatible with all traditional Series 200 mounting plates and with all Domi snap-on mounting plates.

**Packing**

Boxes 150 pcs.  
 Pallets 3.600 pcs.

**E min:**

61 mm for Series 200 mounting plates.  
 70 mm for Domi snap-on mounting plates.  
 74 mm for Domi snap-on mounting plates with back cam.

Use the tables "Drillings and fixings" at page 21 to complete the code number of the desired hinge.

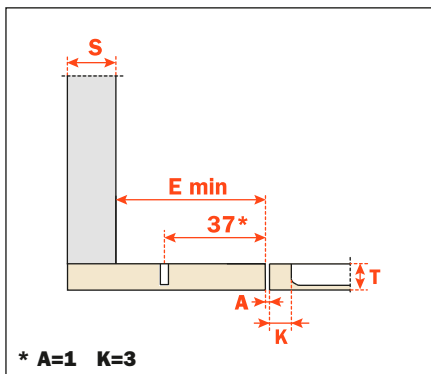
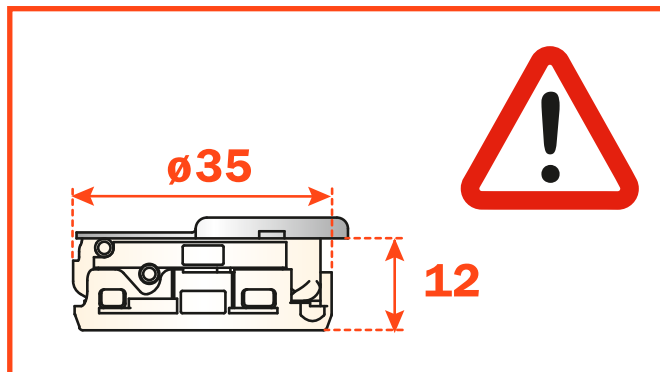

**C1\_6ND9AC**

Heights of mounting plates for every assembly.

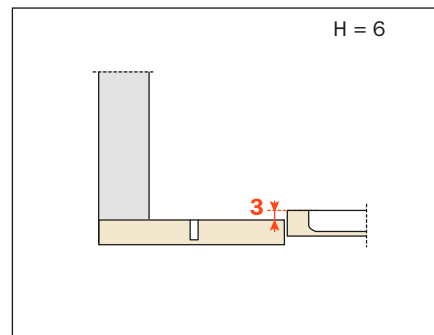
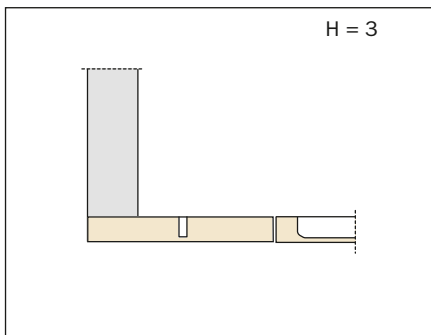
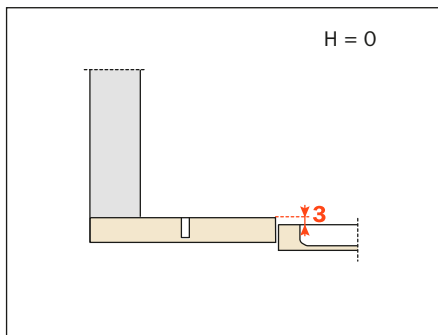

## Silentia - Series 200 for thicker doors



**Hinges with integrated soft-close mechanism in the hinge cup.**

**Bright nickel plated steel cup and arm.**  
**Dimensions of the Ø 35 mm cup.**

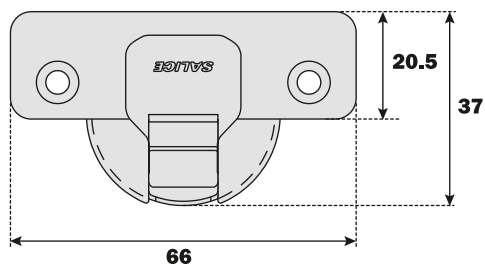

Constant "L" value of 0.7 mm (it does not change during side adjustment).

Approx. number of hinges required according to the door dimension and weight.

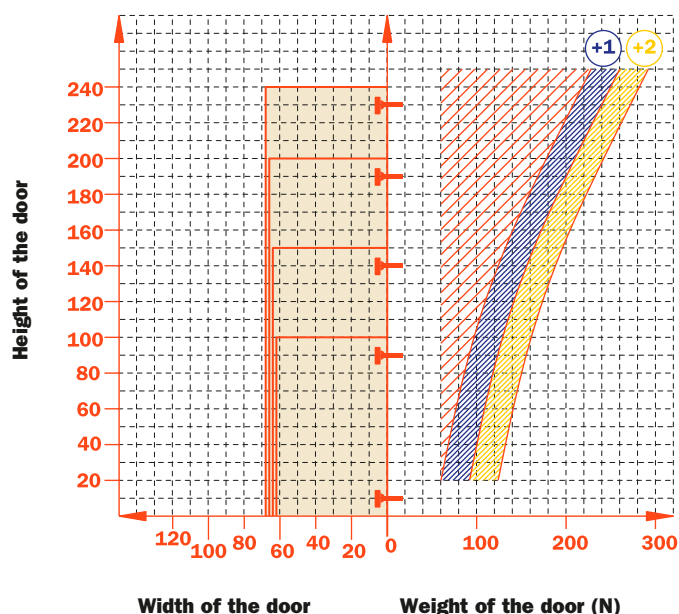



## Adjustments

Compensating side adjustment from -1.5 mm to +4.5 mm.  
 Height adjustment  $\pm 2$  mm.  
 Depth adjustment with Series 200 mounting plates +2.8 mm.  
 Depth adjustment with Domi snap-on mounting plates from -0.5 mm to +2.8 mm.  
 Anti-sliding safety stop.

## Mounting plates

Symmetrical and asymmetrical bright nickel plated steel or die-cast Series 200 mounting plates.  
 Snap-on assembly on Domi mounting plates.  
 Positioning with pre-determined stop on traditional Series 200 mounting plates.

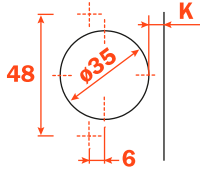
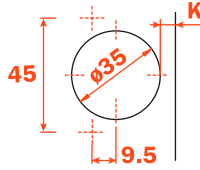
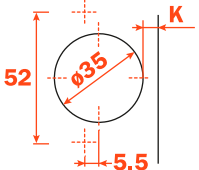
N.B. : Use POZIDRIVE No. 2 screwdrivers for all screws.

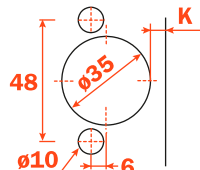
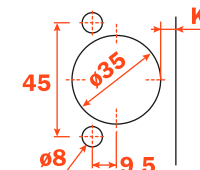
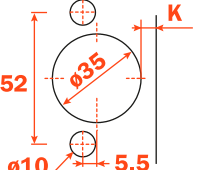
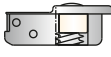
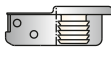
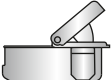
						
<b>Wood screw</b> 	<b>A</b>	<b>A</b>	<b>P</b>	<b>P</b>	<b>U</b>	<b>U</b>
						
<b>Rapido</b> 	<b>6</b>	<b>6</b>	<b>7</b>	<b>7</b>	<b>2</b>	<b>2</b>
<b>Dowel</b> 	<b>B</b>	<b>B</b>	<b>R</b>	<b>R</b>	<b>W</b>	<b>W</b>
<b>Logica</b> 	<b>I</b>	<b>I</b>	<b>J</b>	<b>J</b>	<b>Q</b>	<b>Q</b>

Use this table to identify the available drillings and fixings.

Fill the third position of the hinge code number with the letter or the number corresponding to your choice. I.e.: C2\_BAD9.



Fill this position with the chosen letter or number.

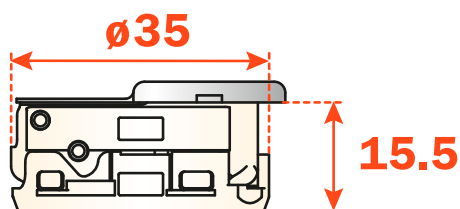

**94°, 155° opening  
and complementary hinges**



**Attention:**  
it is essential to drill the door as specified for the perfect functioning of the hinge.



**Technical information**

**Hinges with integrated soft-close mechanism in the hinge cup.**

**Hinges for min. 18 mm thick doors.  
15.5 mm deep cup.**

94° opening.  
Possible drilling distance on the door (K): from 3 to 9 mm.  
Compatible with all traditional Series 200 mounting plates and with all Domi snap-on mounting plates.

**Space needed to open the door**

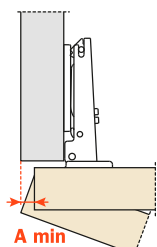

T=	19	20	21	22	23	24	25	26	27	28	29	30	31	32	33	34	35
K=3	<b>A=</b> 0.1	0.2	0.3	0.4	0.5	0.7	0.8	1.0	1.6	2.6	3.5	4.5	5.4	6.4	7.4	8.3	9.3
K=4	<b>A=</b> 0.1	0.2	0.3	0.4	0.5	0.7	0.8	1.0	1.2	1.9	2.8	3.8	4.7	5.7	6.6	7.6	8.6
K=5	<b>A=</b> 0.1	0.2	0.3	0.4	0.5	0.7	0.8	1.0	1.2	1.4	2.2	3.1	4.1	5.0	5.9	6.9	7.8
K=6	<b>A=</b> 0.1	0.2	0.3	0.4	0.5	0.6	0.8	1.0	1.2	1.4	1.7	2.6	3.5	4.4	5.3	6.2	7.2
K=7	<b>A=</b> 0.1	0.2	0.3	0.4	0.5	0.6	0.8	1.0	1.1	1.3	1.6	2.1	3.0	3.8	4.7	5.6	6.5
K=8	<b>A=</b> 0.1	0.2	0.3	0.4	0.5	0.6	0.8	0.9	1.1	1.3	1.6	1.8	2.5	3.3	4.2	5.1	6.0
k=9	<b>A=</b> 0.1	0.2	0.3	0.4	0.5	0.6	0.8	0.9	1.1	1.3	1.5	1.8	2.1	2.9	3.7	4.6	5.4

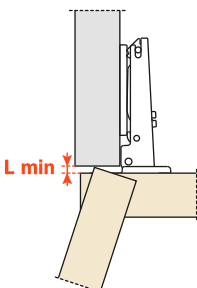

K	3	4	5	6	7	8	9
<b>L=</b>	0.0	0.0	0.0	0.0	0.0	0.3	1.3

The above values are calculated on the assumption that the doors have square edges. They are reduced if the doors have radiussed edges.

**Projection of the door**

Projection of the door from the cabinet side at the max. opening. The figures are based on a straight arm hinge, H=0 mm thickness of mounting plate and K value = 3 mm.

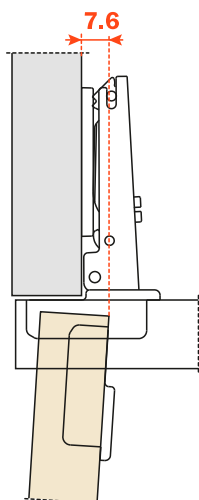

**“C” value**

With this formula you can obtain the max. thickness of the moulded door that can be opened without touching adjacent carcase sides, doors or walls, whilst bearing in mind the above L-K-T values.

$$C = 23 + K + A$$

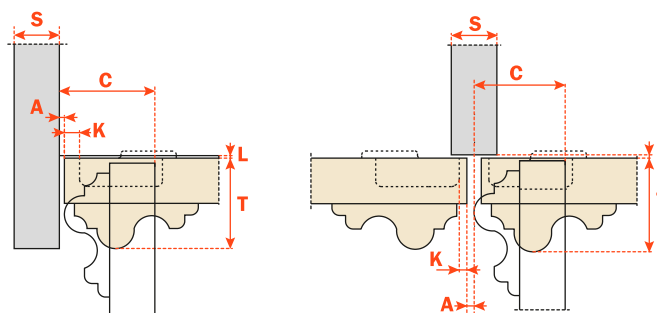

**Packing**

Boxes 300 pcs.  
Pallets 7.200 pcs.

Use these formulas to determine the type of hinge arm, the drilling distance "K" and the height of the mounting plate "H" which is necessary to solve each application problem.

Use the tables "Drillings and fixings" at page 29 to complete the code number of the desired hinge.

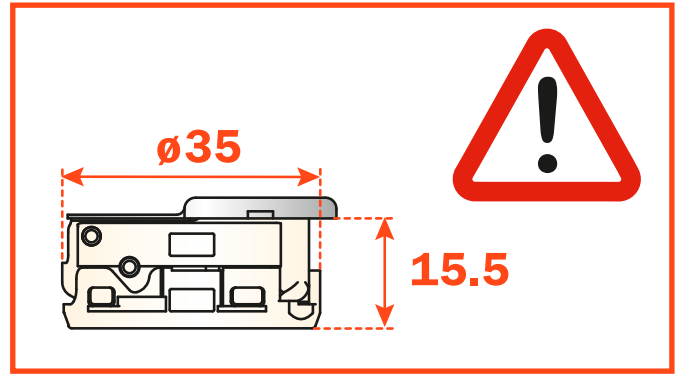
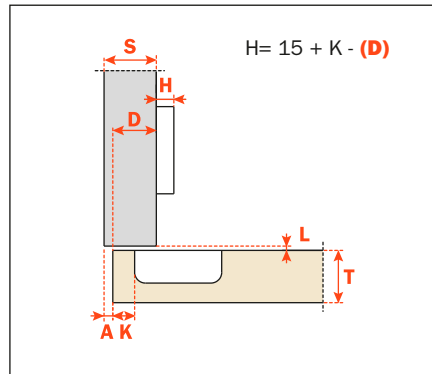
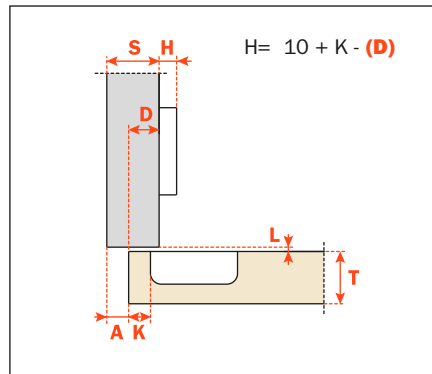
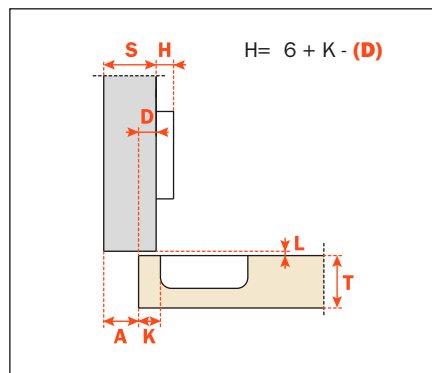
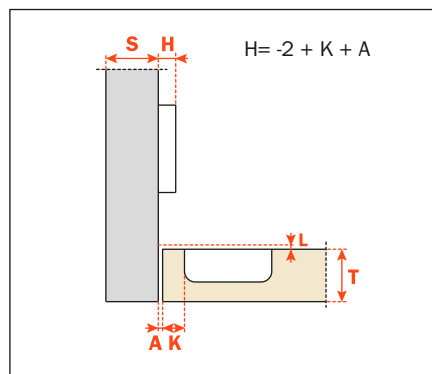
**Arm 0****C2\_BAD9****Arm 5****C2\_BDD9****Arm 9****C2\_BGD9****Arm 17****C2\_BPD9**



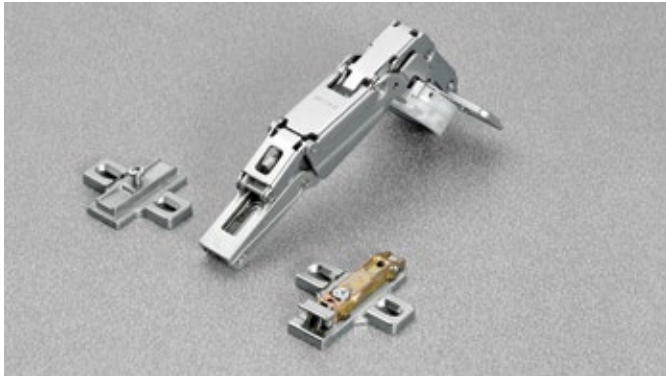

**Technical information**

**Hinges with integrated soft-close mechanism in the hinge cup.**

**Hinges for min. 18 mm thick doors.  
15.5 mm deep cup.**

155° opening.  
Possible drilling distance on the door (K): from 3 to 9 mm.  
Compatible with all traditional Series 200 mounting plates and with all Domi snap-on mounting plates.

**Space needed to open the door**

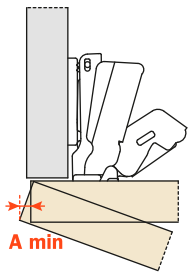

T=	26	27	28	29	30	31	32	33	34	35
K=3	<b>A=</b> 0.0	0.0	0.0	0.8	3.0	4.8	7.1	11.7	16.4	20.7
K=4	<b>A=</b> 0.0	0.0	0.0	0.8	2.5	4.0	6.2	10.6	15.0	19.7
K=5	<b>A=</b> 0.0	0.0	0.0	0.8	2.0	3.4	4.8	9.8	14.1	18.4
K=6	<b>A=</b> 0.0	0.0	0.0	0.8	1.5	2.8	4.2	8.7	13.2	17.8
K=7	<b>A=</b> 0.0	0.0	0.0	0.8	1.4	2.3	3.0	7.8	12.0	16.7
K=8	<b>A=</b> 0.0	0.0	0.0	0.2	0.9	1.9	2.7	7.0	11.2	15.7
K=9	<b>A=</b> 0.0	0.0	0.0	0.2	0.7	1.5	2.1	5.9	10.4	15.0

**The above values are calculated on the assumption that the doors have square edges. They are reduced if the doors have radiussed edges.**

**“C” value**

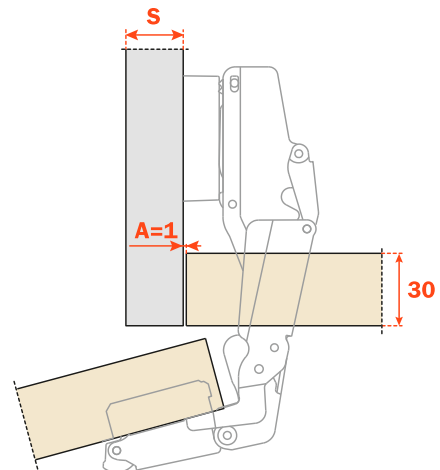
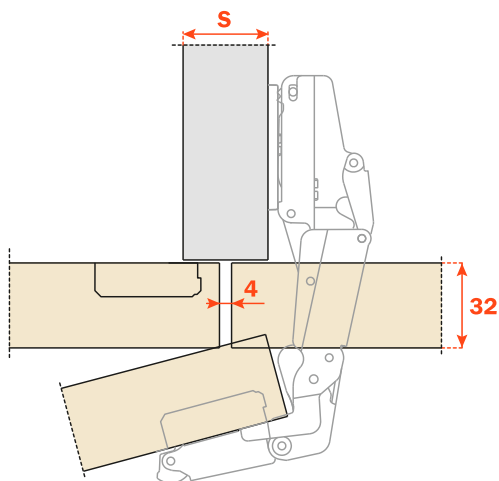



**Packing**

Boxes 100 pcs.  
Pallets 2.400 pcs.

Use these formulas to determine the type of hinge arm, the drilling distance "K" and the height of the mounting plate "H" which is necessary to solve each application problem.

To limit the opening of the hinge, see page 362 chapter "Accessories".

Use the tables "Drillings and fixings" at page 29 to complete the code number of the desired hinge.

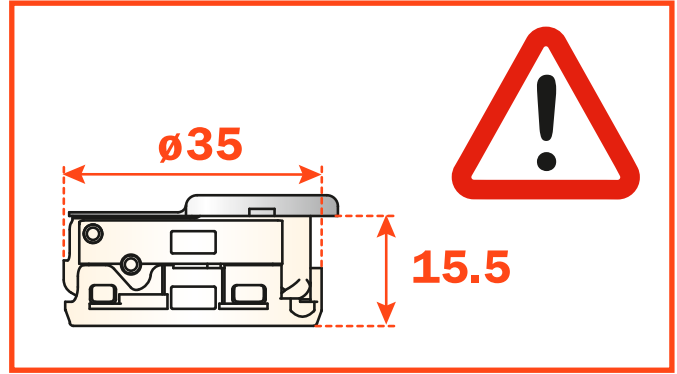

**Arm 0**

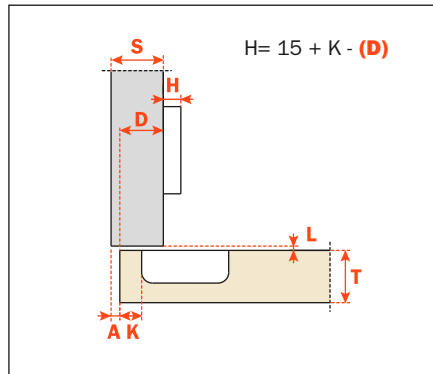
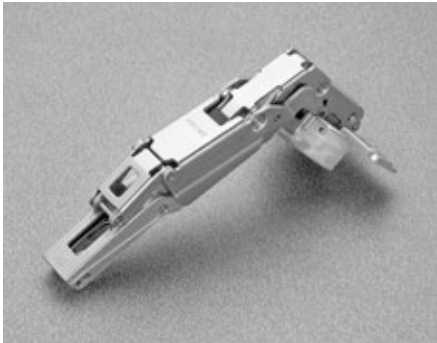

**C2\_DAD9**

**Arm 5**

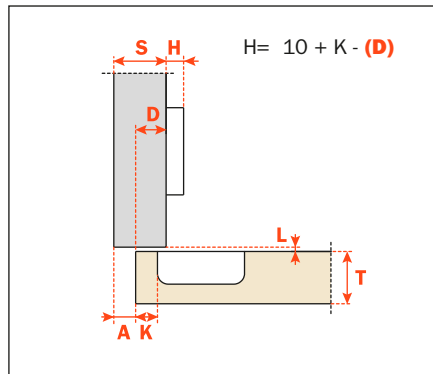
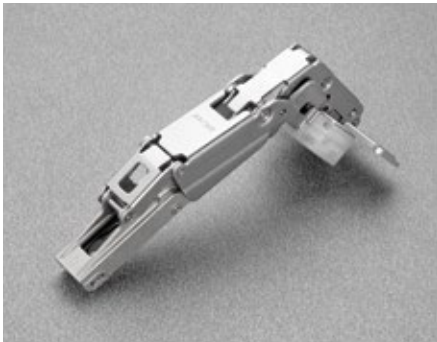

**C2\_DDD9**

**Arm 9**

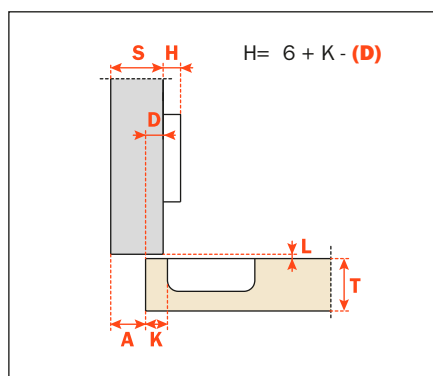

**C2\_DGD9**



**Technical information**

**Hinges with integrated soft-close mechanism in the hinge cup.**

**For wooden doors with positive angled assembly.**

**Hinges for min. 18 mm thick doors.**

**15.5 mm deep cup.**

94° opening.

Possible drilling distance on the door (K): from 3 to 9 mm.

Compatible with all traditional Series 200 mounting plates and with all Domi snap-on mounting plates.

**Packing**

Boxes 150 pcs.

Pallets 3.600 pcs.

The solution of assembly problems where doors are mounted at a positive angle requires the verification of drilling distances by a practical trial. Please do not hesitate to consult our technical support department for assistance.

Use the tables "Drillings and fixings" at page 29 to complete the code number of the desired hinge.

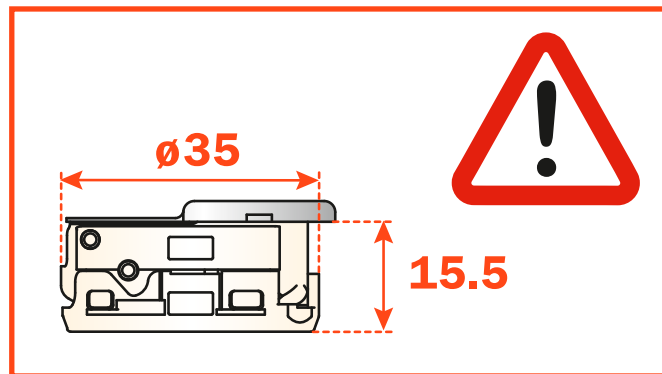

**Arm 15°**

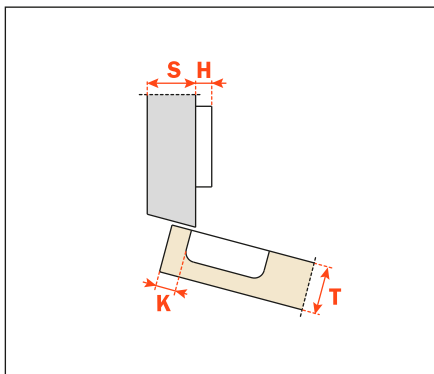

**C2\_BZD9**

**Arm 24°**

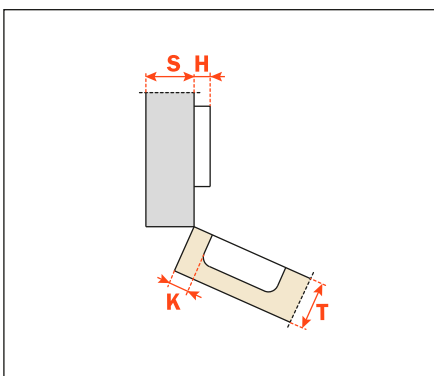

**C2\_BUD9**

**Arm 30°**

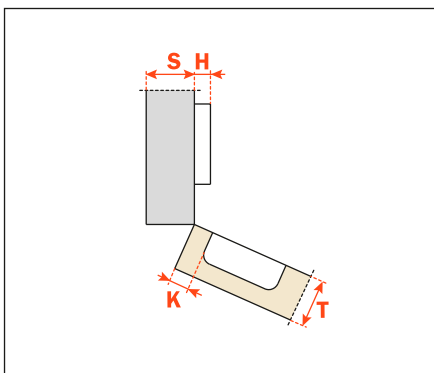

**C2\_BED9**

Arm 30°

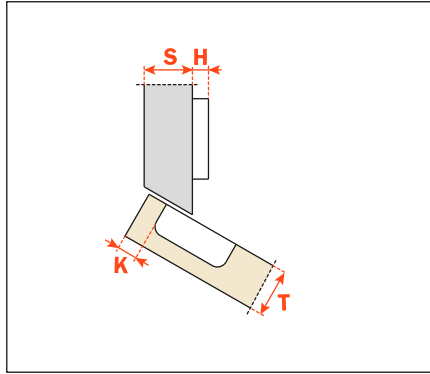

**C2\_BTD9**

Arm 37°

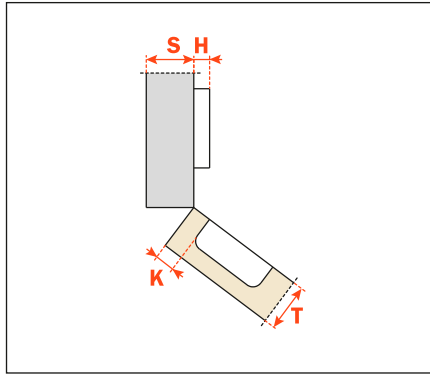

**C2\_BKD9**

Arm 45°

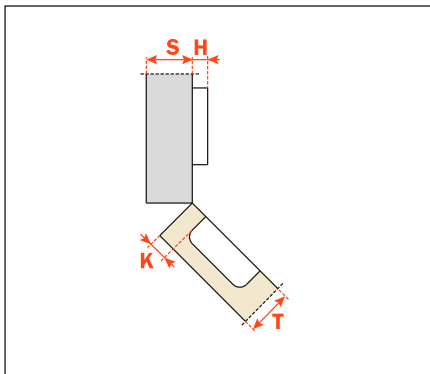

**C2\_BMD9**

Arm 45°

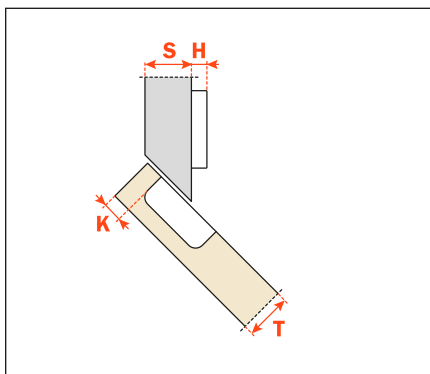

**C2\_BVD9**

Arm 45°

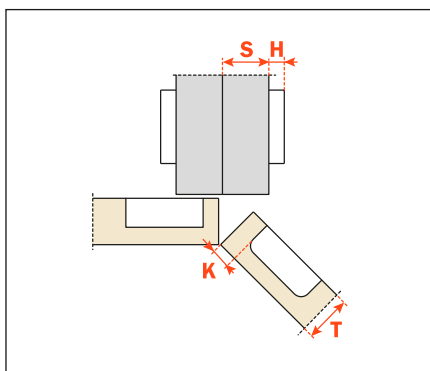

**C2\_BMD9AC**



**Technical information**

**Hinges with integrated soft-close mechanism in the hinge cup.**

**Crampon hinges.**  
**For cabinet sides with 37x32 mm standard drilling.**  
**Hinges for min. 18 mm thick doors.**  
**15.5 mm deep cup.**

94° opening.  
 Possible drilling distance on the door (K): from 3 to 9 m.  
 Compatible with all traditional Series 200 mounting plates and with all Domi snap-on mounting plates.

**Packing**

Boxes 150 pcs.  
 Pallets 3.600 pcs.

**E min:**

61 mm for Series 200 mounting plates.  
 70 mm for Domi snap-on mounting plates.  
 74 mm for Domi snap-on mounting plates with back cam.

Use the tables "Drillings and fixings" at page 29 to complete the code number of the desired hinge.

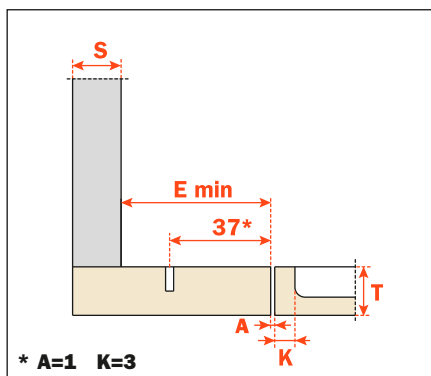
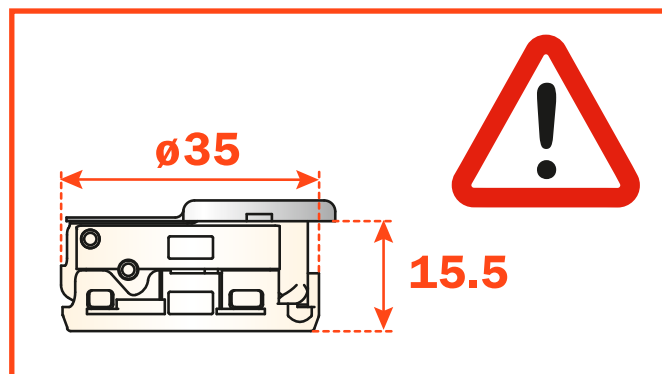

**C2\_BND9AC**

Heights of mounting plates for every assembly.

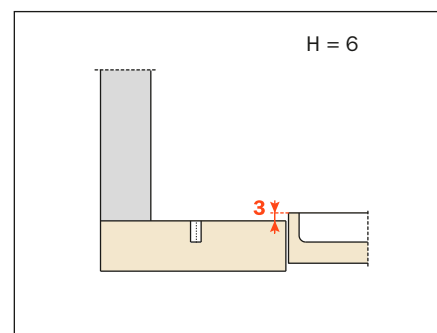
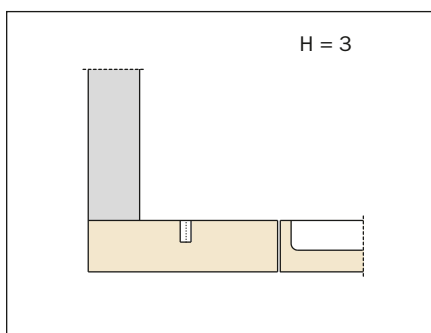
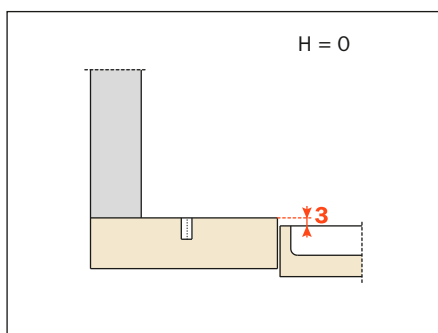

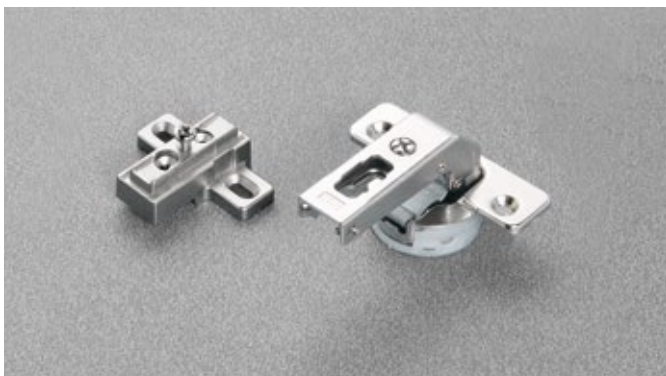

## Technical information

Hinges with integrated soft-close mechanism in the hinge cup.

### Crampon hinges.

For smaller spaces with 15x32 mm drilling.

Hinges for min. 18 mm thick doors.

15.5 mm deep cup.

94° opening.

Possible drilling distance on the door (K): from 3 to 9 mm.

Compatible with all traditional Series 200 mounting plates,

28x32 mm drilling.

**NOT COMPATIBLE** with Domi snap-on mounting plates.

### Packing

Boxes 150 pcs.

Pallets 3.600 pcs.

Use the tables "Drillings and fixings" at page 29 to complete the code number of the desired hinge.

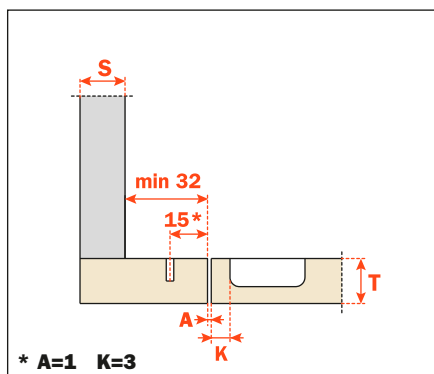
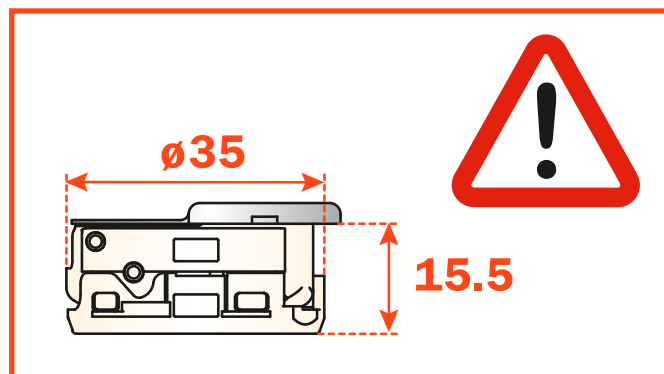

**C2\_BND9**

Heights of mounting plates for every assembly.

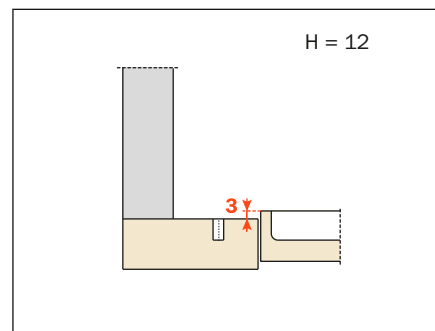
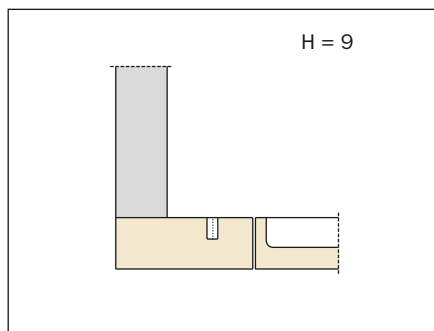
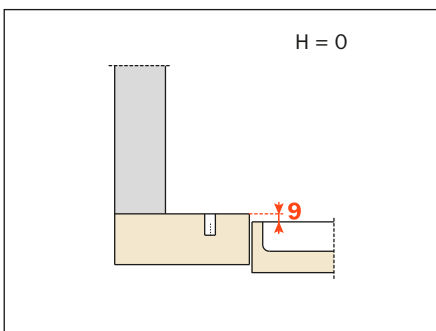



## Silentia - For metal profiles



Silentia - For metal profiles





## Technical information

**Hinges with integrated soft-close mechanism in the hinge cup.**

**Hinges specially developed for use with metal profiles.**

105° opening.

We recommend the use of countersunk flat head self tapping screws  $\varnothing 2.9 \times 6.5$  UNI 6955 DIN 7982 to fix C1Z6 hinges.

Compatible with all traditional Series 200 mounting plates and with all Domi snap-on mounting plates.

### Packing

Boxes 150 pcs.

Pallets 3.600 pcs.

Arm 0

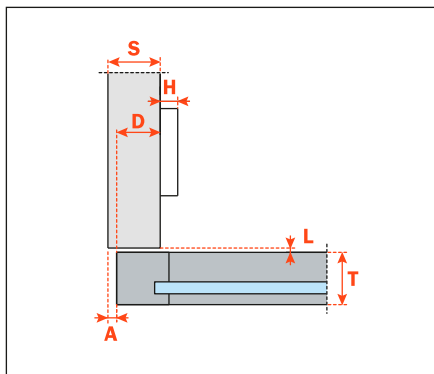

**C1Z6AD9**

Arm 5

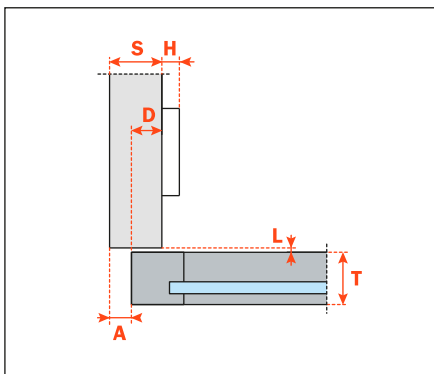

**C1Z6DD9**

Arm 9

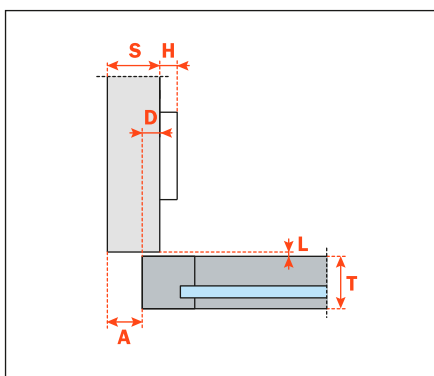

**C1Z6GD9**

Arm 17

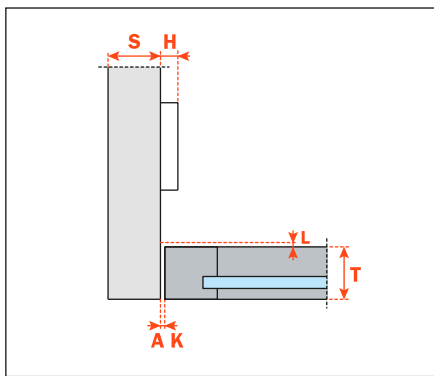

**C1Z6PD9**





**Technical information**

**Hinges with integrated soft-close mechanism in the hinge cup.**

**For doors with positive angled assembly.**

**Hinges specially developed for use with metal profiles.**

105° opening.

We recommend the use of countersunk flat head self tapping screws  $\varnothing$  2.9 x 6.5 UNI 6955 DIN 7982 to fix C1Z6 hinges.

Compatible with all traditional Series 200 mounting plates and with all Domi snap-on mounting plates.

**Packing**

Boxes 150 pcs.

Pallets 3.600 pcs.

Arm 30°

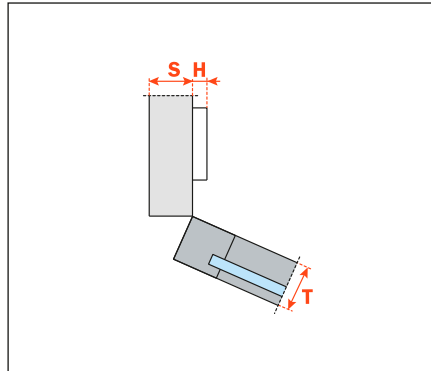

**C1Z6ED9**

Arm 45°

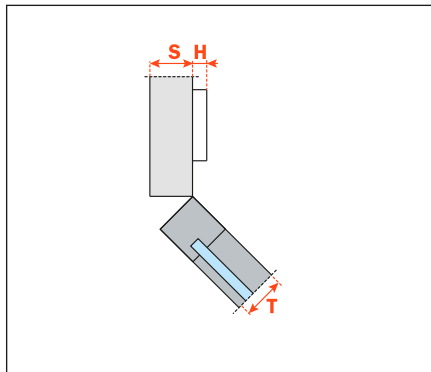

**C1Z6MD9**



Fancy cover for hinge (should be ordered separately)

**D1Z6HSK**



**Technical information**

**Hinges with integrated soft-close mechanism in the hinge cup.**

**Crampon hinges.**

**For cabinet sides with 37x32 mm standard drilling.**  
**Hinges specially developed for use with metal profiles.**

105° opening.

We recommend the use of countersunk flat head self tapping screws  $\varnothing$  2.9 x 6.5 UNI 6955 DIN 7982 to fix C1Z6 hinges.

Compatible with all traditional Series 200 mounting plates and with all Domi snap-on mounting plates.

**Packing**

Boxes 150 pcs.  
 Pallets 3.600 pcs.

**E min:**

61 mm for Series 200 mounting plates.

70 mm for Domi snap-on mounting plates.

74 mm for Domi snap-on mounting plates with back cam.

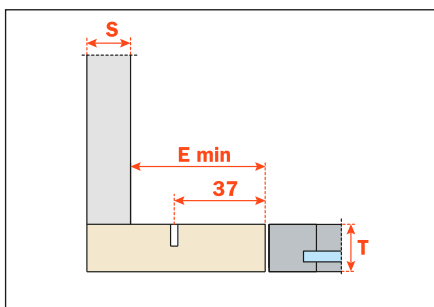

**C1Z6ND9AC**



Fancy cover for hinge (should be ordered separately)

**D1Z6HSK**



**Technical information**

**Hinges with integrated soft-close mechanism in the hinge cup.**

**Crampon hinges.**

**For smaller spaces with 15x32 mm drilling.**

**Hinges specially developed for use with metal profiles.**

105° opening.

We recommend the use of countersunk flat head self tapping screws  $\varnothing$  2.9 x 6.5 UNI 6955 DIN 7982 to fix C1Z6 hinges.

Compatible with all traditional Series 200 mounting plates, drilling 28x32 mm.

**NOT COMPATIBLE** with Domi snap-on mounting plates.

**Packing**

Boxes 150 pcs.  
 Pallets 3.600 pcs.

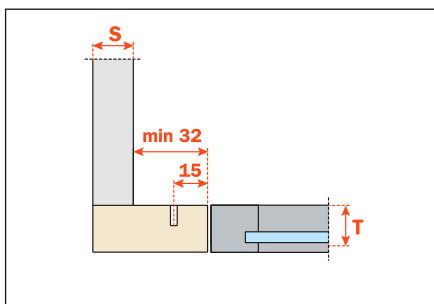

**C1Z6ND9**



Fancy cover for hinge (should be ordered separately)

**D1Z6HSK**

## Drilling of the metal profile

Countersunk flat head self tapping screws  $\varnothing 2.9 \times 6.5$  UNI 6955 - DIN 7982

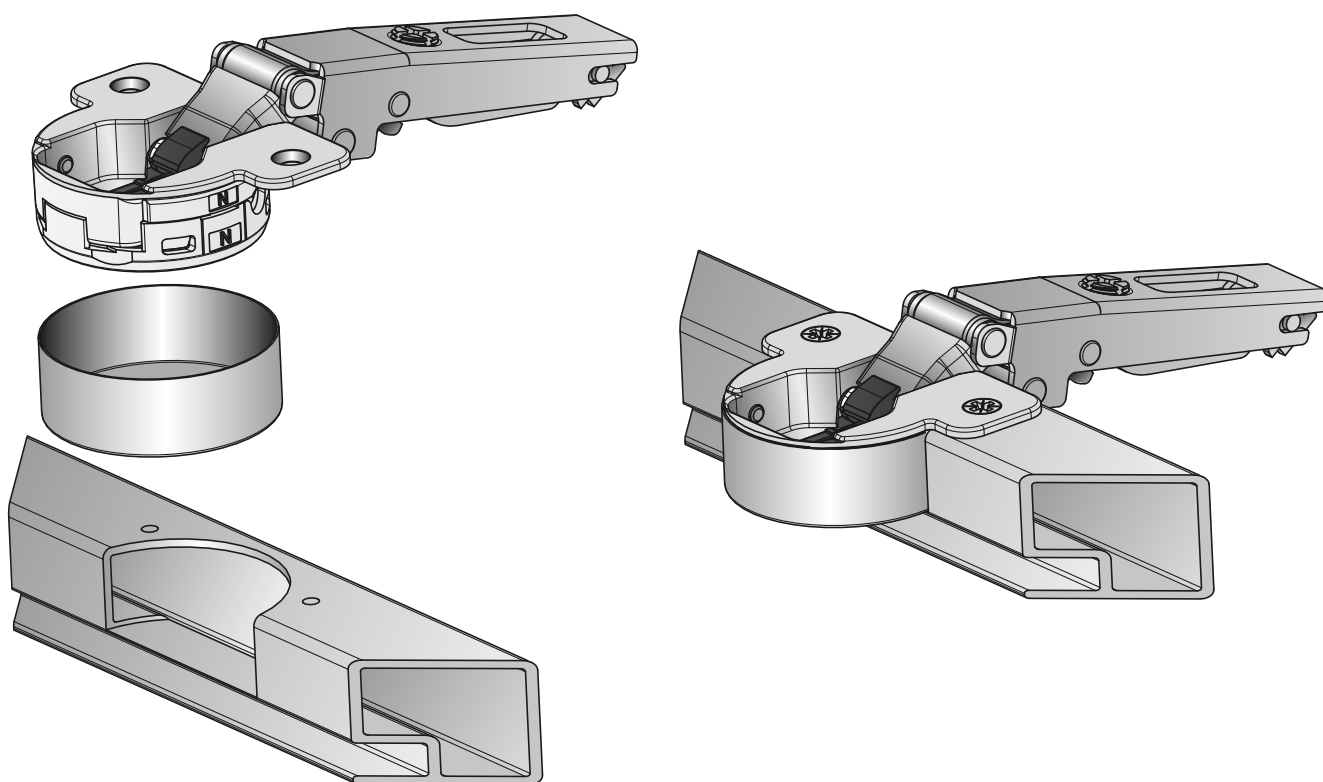
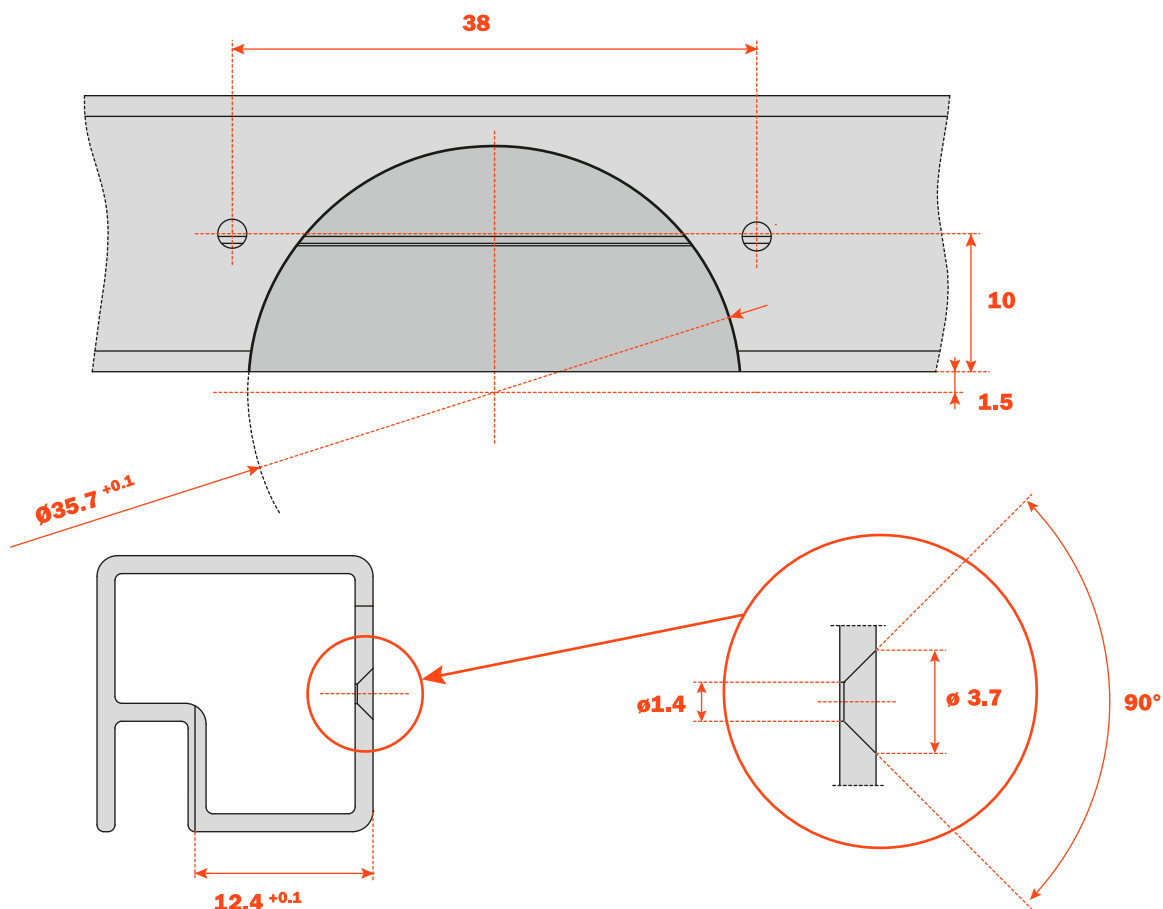



## Silentia - Series 700



**Hinges with integrated soft-close mechanism in the hinge cup.**

**Bright nickel plated steel cup and arm.**  
**Dimensions of the Ø 35 mm cup.**

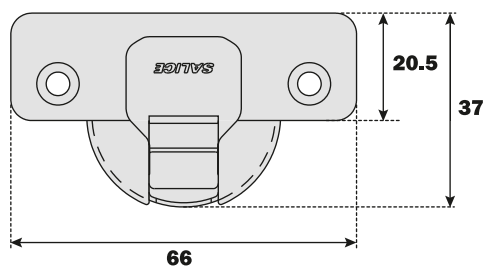

Constant "L" value of 0.7 mm (it does not change during side adjustment).

Approx. number of hinges required according to the door dimension and weight.

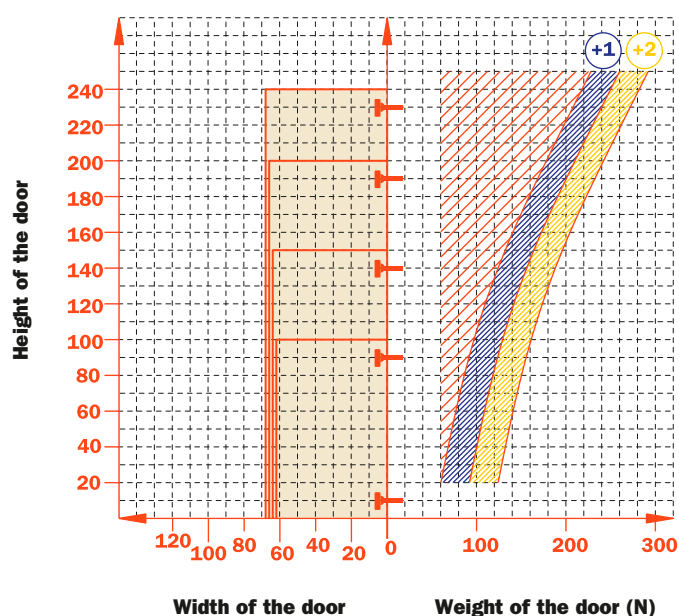

### Adjustments

Compensated side adjustment from -1.5 mm to +4.5 mm.  
 Height adjustment  $\pm 2$  mm.  
 Depth adjustment with Series 200 mounting plates +2.8 mm.  
 Depth adjustment with Domi snap-on mounting plates from -0.5 mm to +2.8 mm.  
 Anti-sliding safety stop.

### Mounting plates

Symmetrical and asymmetrical bright nickel plated steel or die-cast Series 200 mounting plates.  
 Snap-on assembly on Domi mounting plates.  
 Positioning with pre-determined stop on traditional Series 200 mounting plates.

N.B. : Use POZIDRIVE No. 2 screwdrivers for all screws.

<b>Wood screw</b>		A	A	P	P	U	U
<b>Rapido</b>		6	6	7	7	2	2
<b>Dowel</b>		B	B	R	R	W	W
<b>Logica</b>		I	I	J	J	Q	Q

Use this table to identify the available drillings and fixings.

Fill the third position of the hinge code number with the letter or the number corresponding to your choice. I.e.: C7\_6AD9.

↑  
Fill this position with the chosen letter or number.

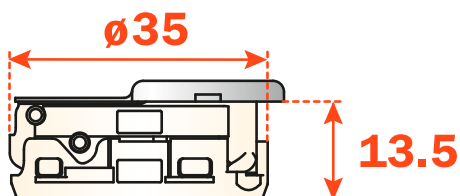

**110°, 155° opening  
and complementary hinges**



**Attention:**  
it is essential to drill the door as specified for the perfect functioning of the hinge.



**Technical information**

**Hinges with integrated soft-close mechanism in the hinge cup.**

**Hinges for min. 16 mm thick doors.  
13.5 mm deep cup.**

110° opening.  
Possible drilling distance on the door (K): from 3 to 6 mm.  
Compatible with all traditional Series 200 mounting plates and with all Domi snap-on mounting plates.

**Space needed to open the door**

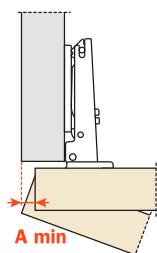

	T=	16	17	18	19	20	21	22	23	24	25	26
K=3	<b>A=</b>	0.7	0.9	1.1	1.3	1.6	1.9	2.2	2.6	3.2	4.4	5.7
K=4	<b>A=</b>	0.6	0.8	1.1	1.3	1.6	1.8	2.2	2.5	2.9	3.4	4.7
K=5	<b>A=</b>	0.6	0.8	1.0	1.3	1.5	1.8	2.1	2.4	2.8	3.2	3.7
K=6	<b>A=</b>	0.6	0.8	1.0	1.2	1.5	1.8	2.1	2.4	2.7	3.1	3.6

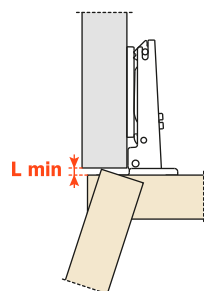

	T=	16	17	18	19	20	21	22	23	24	25	26
K=3	<b>L=</b>	0.0	0.0	0.0	0.0	0.0	0.0	0.0	0.2	0.4	0.6	0.9
K=4	<b>L=</b>	0.0	0.0	0.0	0.3	0.5	0.7	0.9	1.1	1.4	1.6	1.8
K=5	<b>L=</b>	0.6	0.8	1.0	1.2	1.5	1.7	1.9	2.1	2.4	2.6	2.8
K=6	<b>L=</b>	1.5	1.8	2.0	2.2	2.4	2.7	2.9	3.1	3.3	3.6	3.8

**The above values are calculated on the assumption that the doors have square edges. They are reduced if the doors have radiussed edges.**

**Projection of the door**

Projection of the door from the cabinet side at the max. opening. The figures are based on a straight arm hinge, H=0 mm thickness of mounting plate and K value = 3 mm.

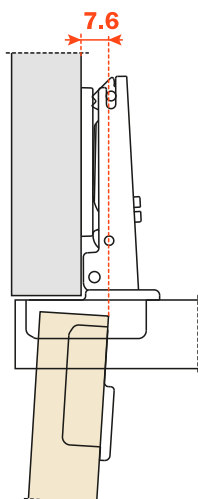

**“C” value**

With this formula you can obtain the max. thickness of the moulded door that can be opened without touching adjacent carcass sides, doors or walls, whilst bearing in mind the above L-K-T values.

$C = 22.5 + K + A$

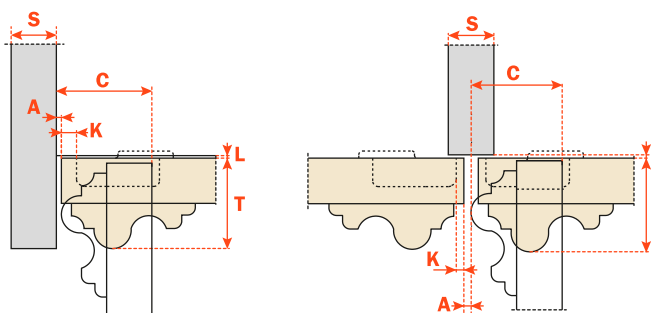



**Packing**

Boxes 300 pcs.  
Pallets 7.200 pcs.

Use these formulas to determine the type of hinge arm, the drilling distance "K" and the height of the mounting plate "H" which is necessary to solve each application problem.

Use the tables "Drillings and fixings" at page 47 to complete the code number of the desired hinge.

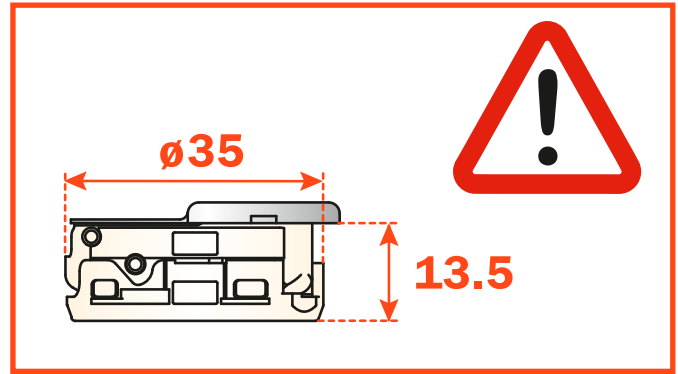
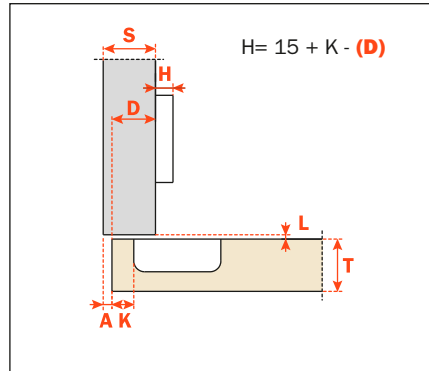
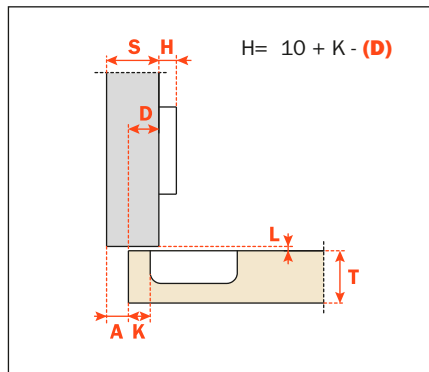
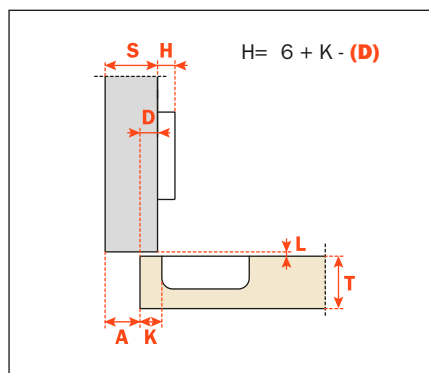
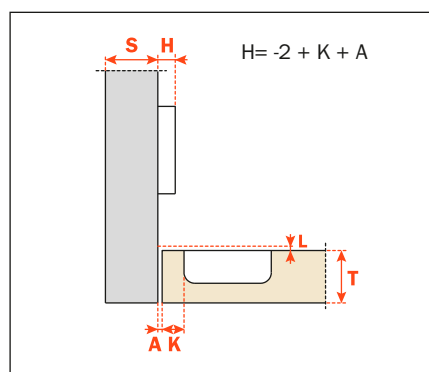
**Arm 0****C7\_6AD9****Arm 5****C7\_6DD9****Arm 9****C7\_6GD9****Arm 17****C7\_6PD9**

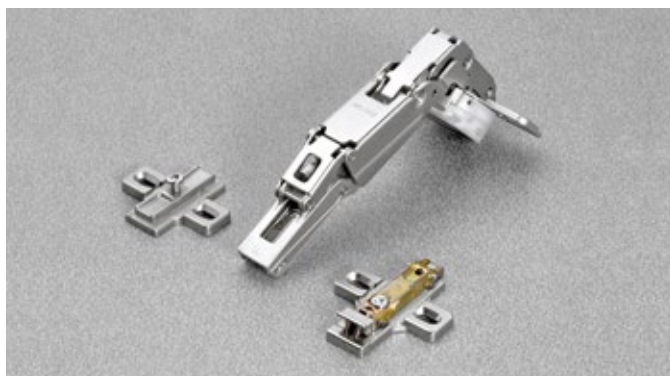

**Technical information**

**Hinges with integrated soft-close mechanism in the hinge cup.**

**Hinges for thick doors 16 mm min.  
13.5 mm deep cup.**

155° opening.  
Possible drilling distance on the door (K): from 3 to 8 mm.  
Compatible with all traditional Series 200 mounting plates and with all Domi snap-on mounting plates.

**Space needed to open the door**

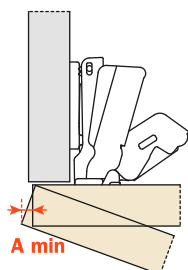

T=	16	18	20	22
K=3 <b>A=</b>	0.0	0.0	0.3	1.2
K=4 <b>A=</b>	0.0	0.4	0.4	1.3
K=5 <b>A=</b>	0.0	0.1	0.5	1.6
K=6 <b>A=</b>	0.0	0.1	1.2	3.0
K=7 <b>A=</b>	0.0	0.1	0.7	2.5
K=8 <b>A=</b>	0.0	0.0	0.6	1.9

**The above values are calculated on the assumption that the doors have square edges. They are reduced if the doors have radiussed edges.**

**“C” value**

For spaces with removable components. The door combined with a mounting plate H=0 and a straight arm hinge opens at 90° with lateral door protrusion of 2 mm.

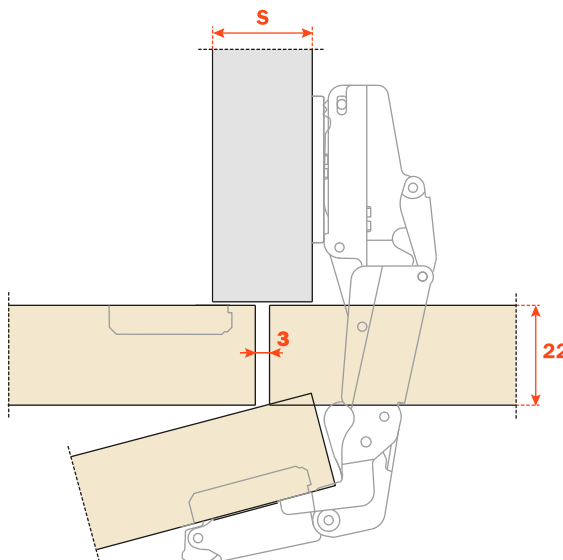
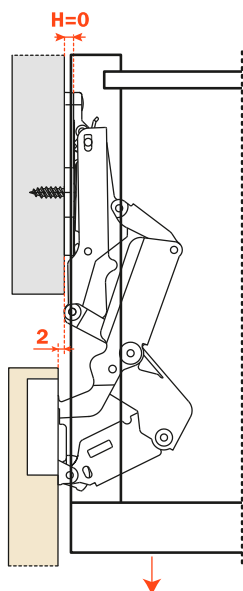

**Packing**

Boxes 100 pcs.  
Pallets 2.400 pcs.

Use these formulas to determine the type of hinge arm, the drilling distance "K" and the height of the mounting plate "H" which is necessary to solve each application problem.

To limit the opening of the hinge, see page 362 chapter "Accessories".

Use the tables "Drillings and fixings" at page 47 to complete the code number of the desired hinge.

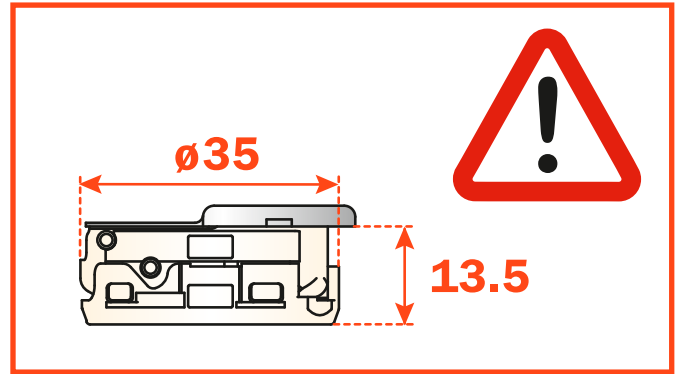
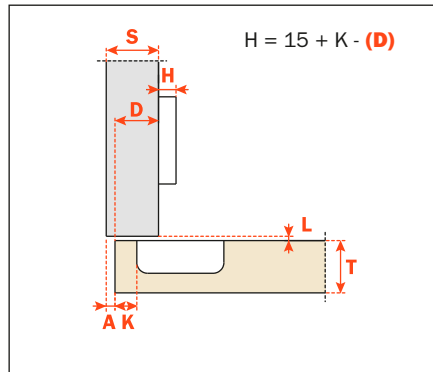
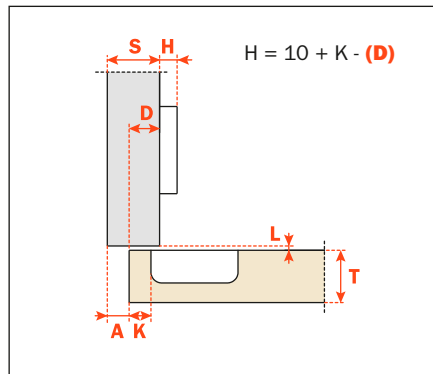
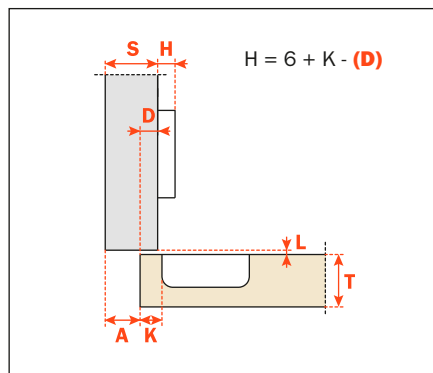
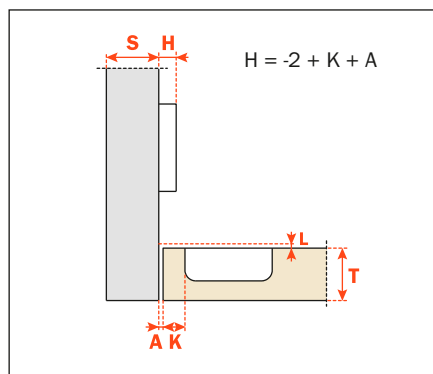
**Arm 0****C2\_MAD9****Arm 5****C2\_MDD9****Arm 9****C2\_MGD9****Arm 17****C2\_MPD9**



**Technical information**

**Hinges with integrated soft-close mechanism in the hinge cup.**

**For wooden doors with positive angled assembly.**

**Hinges for min. 16 mm thick doors.**

**13.5 mm deep cup.**

110° opening.

Possible drilling distance on the door (K): from 3 to 6 mm.

Compatible with all traditional Series 200 mounting plates and with all Domi snap-on mounting plates.

**Packing**

Boxes 150 pcs.

Pallets 3.600 pcs.

The solution of assembly problems where doors are mounted at a positive angle requires the verification of drilling distances by a practical trial. Please do not hesitate to consult our technical support department for assistance.

Use the tables "Drillings and fixings" at page 47 to complete the code number of the desired hinge.

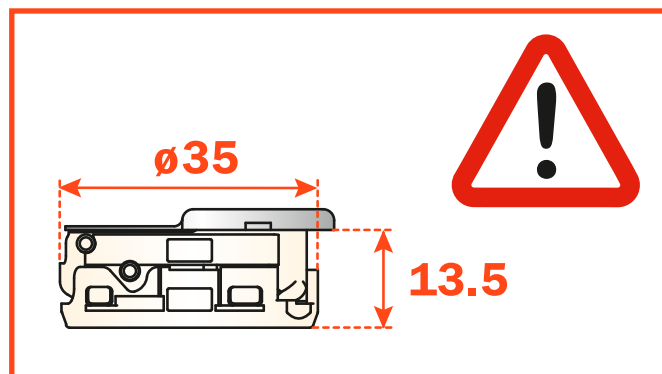

Arm **15°**

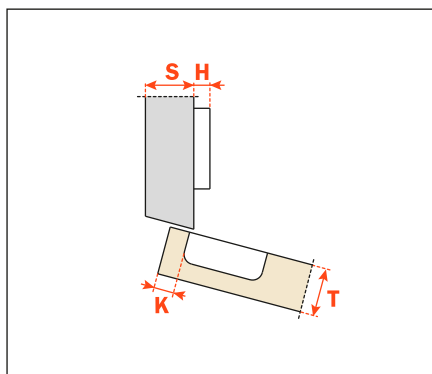

**C7\_6ZD9**

Arm **24°**

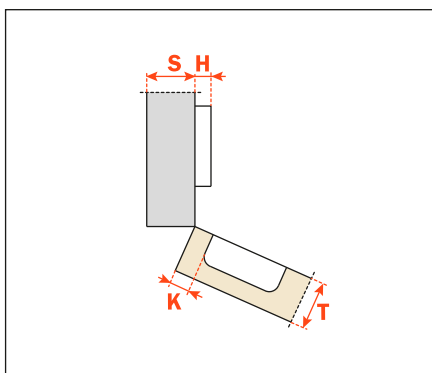

**C7\_6UD9**

Arm **30°**

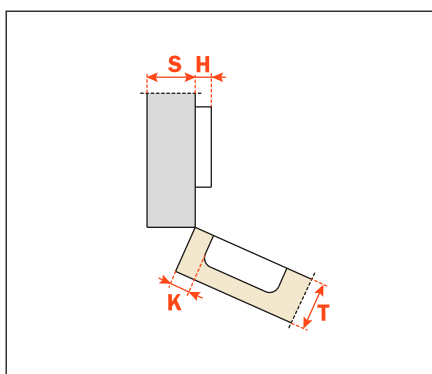

**C7\_6ED9**

Arm 30°

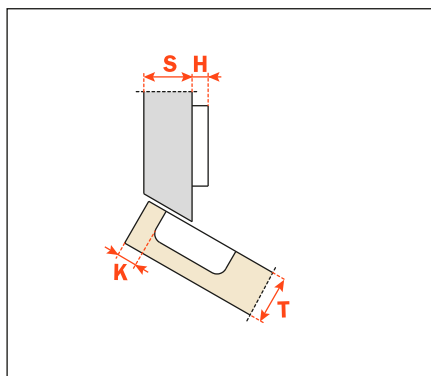

**C7\_6TD9**

Arm 37°

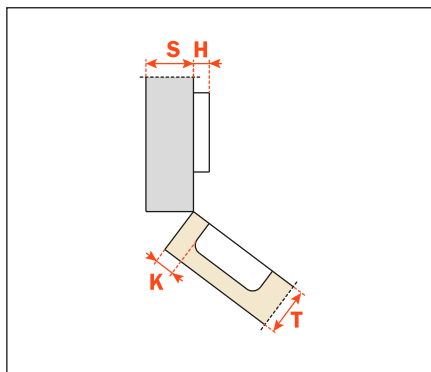

**C7\_6KD9**

Arm 45°

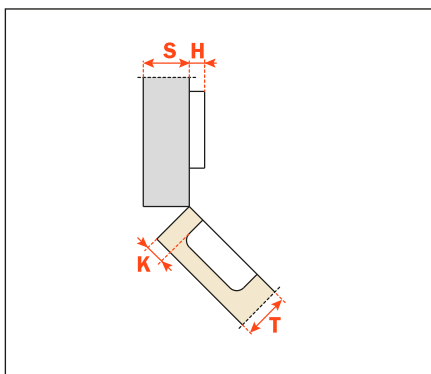

**C7\_6MD9**

Arm 45°

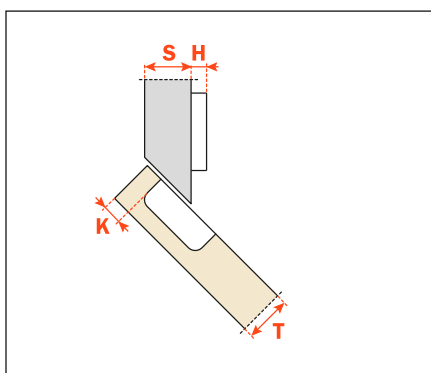

**C7\_6VD9**

Arm 45°

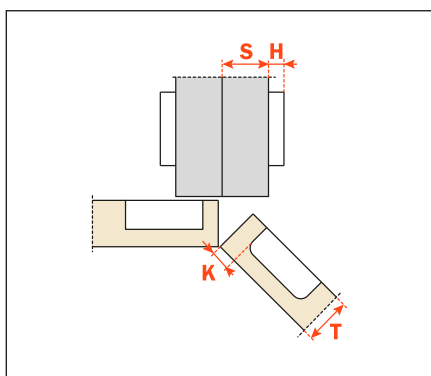

**C7\_6MD9AC**





**Technical information**

**Hinges with integrated soft-close mechanism in the hinge cup.**

**For wooden doors with negative angled assembly.**

**Hinges for min. 16 mm thick doors.**

**13.5 mm deep cup.**

110° opening.

Possible drilling distance on the door (K): from 3 to 6 mm.

Compatible with all traditional Series 200 mounting plates and with all Domi snap-on mounting plates.

**Packing**

Boxes 150 pcs.

Pallets 3.600 pcs.

The solution of assembly problems where doors are mounted at a negative angle requires the verification of drilling distances by a practical trial. Please do not hesitate to consult our technical support department for assistance.

Use the tables "Drillings and fixings" at page 47 to complete the code number of the desired hinge.

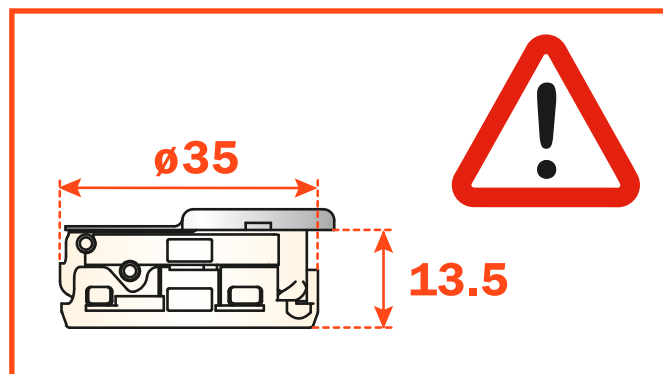

Arm **-30°**

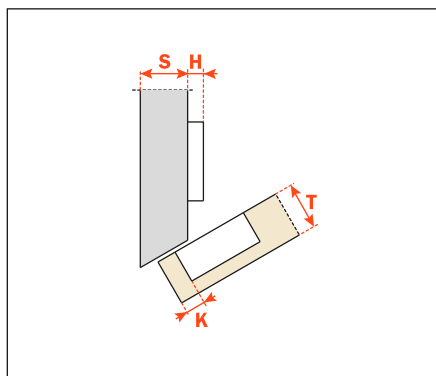
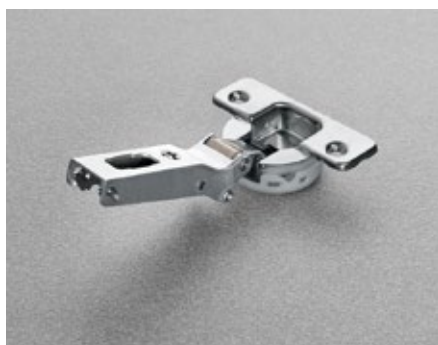

**C7\_6WD9**



## Technical information

Hinges with integrated soft-close mechanism in the hinge cup.

**Crampon hinges.**

**For cabinet sides with 37x32 mm standard drilling.**

**Hinges for min. 16 mm thick doors.**

**13.5 mm deep cup.**

110° opening.

Possible drilling distance on the door (K): from 3 to 6 mm.

Compatible with all traditional Series 200 mounting plates and with all Domi snap-on mounting plates.

### Packing

Boxes 150 pcs.

Pallets 3.600 pcs.

### E min:

61 mm for Series 200 mounting plates.

70 mm for Domi snap-on mounting plates.

74 mm for Domi snap-on mounting plates with back cam.

Use the tables "Drillings and fixings" at page 47 to complete the code number of the desired hinge.

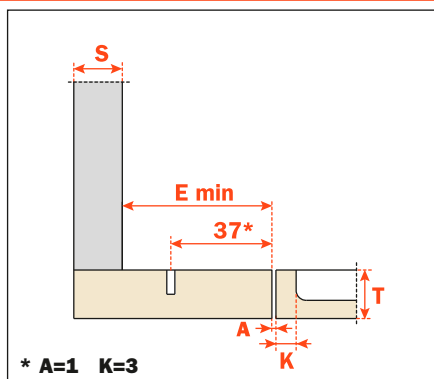
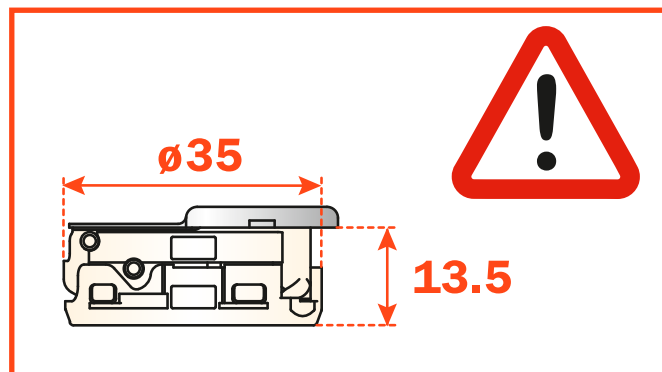

**C7\_6ND9AC**

Heights of mounting plates for every assembly.

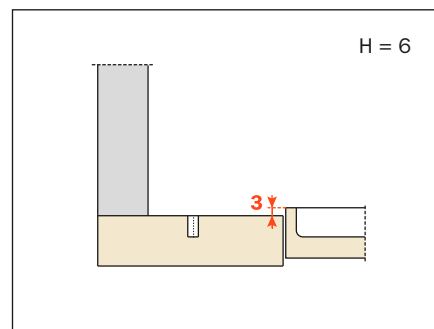
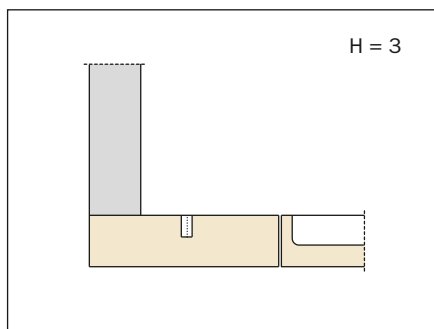
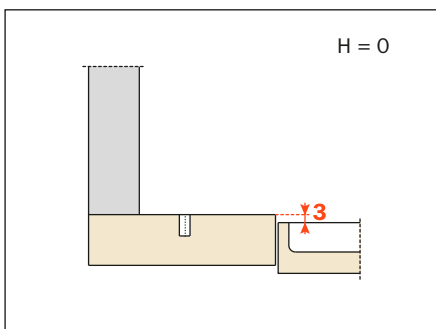



**Technical information**

**Hinges with integrated soft-close mechanism in the hinge cup.**

**Long crampton hinges.  
Hinges for min. 16 mm thick doors.  
13.5 mm deep cup.**

110° opening.  
Possible drilling distance on the door (K): from 3 to 6 m.  
Compatible with all traditional Series 200 mounting plates and with all Domi snap-on mounting plates.

**Packing**

Boxes 150 pcs.  
Pallets 3.600 pcs.

**E min:**

61 mm for Series 200 mounting plates.  
70 mm for Domi snap-on mounting plates.  
74 mm for Domi snap-on mounting plates with back cam.

Use the tables "Drillings and fixings" at page 47 to complete the code number of the desired hinge.

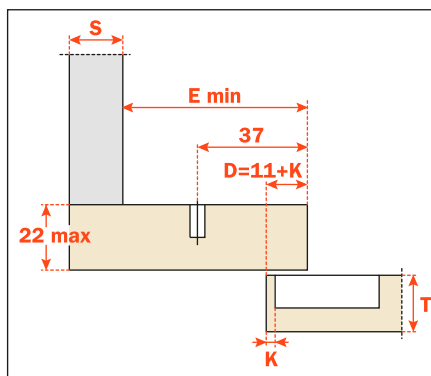
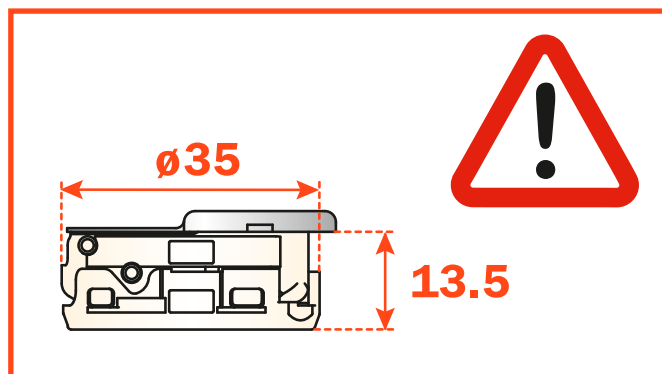

**C7\_6ND9AM**

Heights of mounting plates for every assembly.

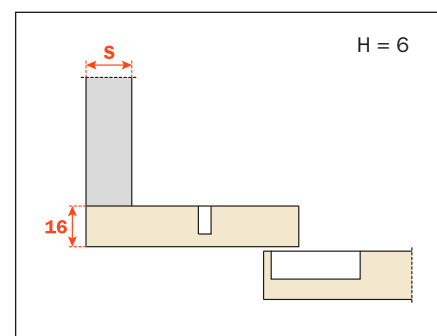
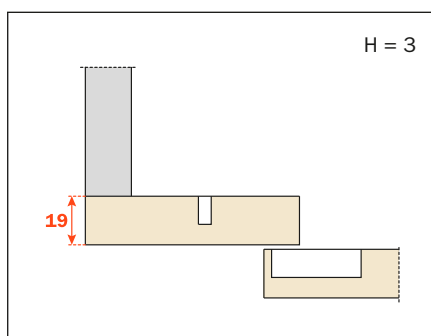
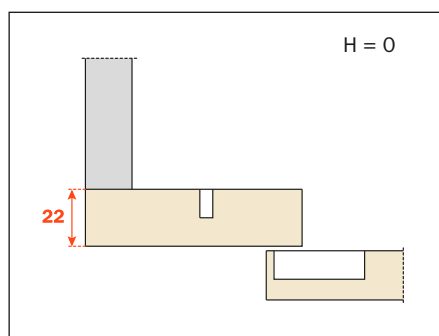



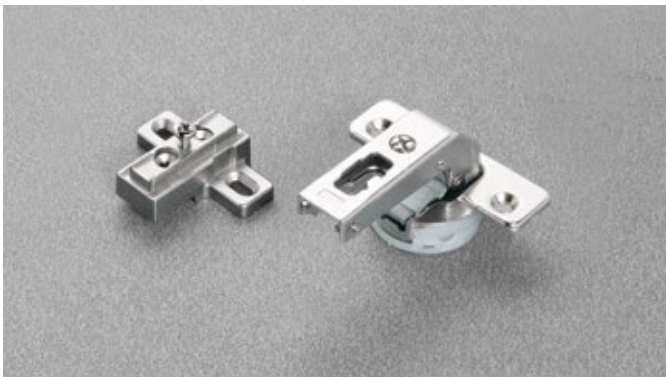

## Technical information

### Hinges with integrated soft-close mechanism in the hinge cup.

#### Crampon hinges.

For smaller spaces with 15x32 mm drilling.

Hinges for min. 16 mm thick doors.

13.5 mm deep cup.

110° opening.

Possible drilling distance on the door (K): from 3 to 6 mm.

Compatible with all traditional Series 200 mounting plates,

28x32 mm drilling.

**NOT COMPATIBLE** with Domi snap-on mounting plates.

### Packing

Boxes 150 pcs.

Pallets 3.600 pcs.

Use the tables "Drillings and fixings" at page 47 to complete the code number of the desired hinge.

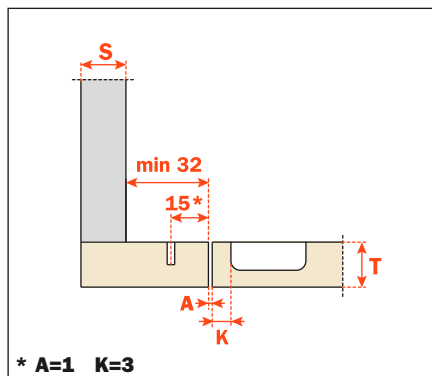
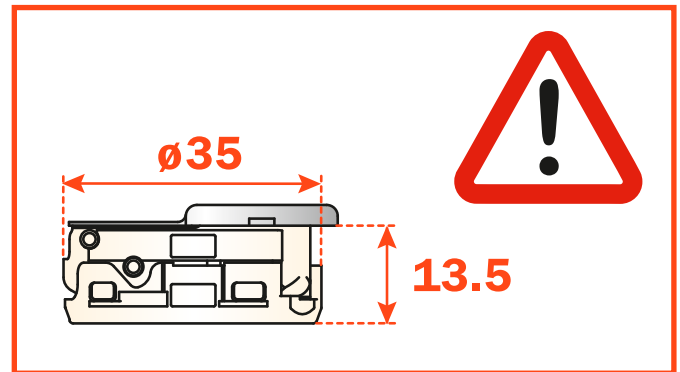

**C7\_6ND9**

Heights of mounting plates for every assembly.

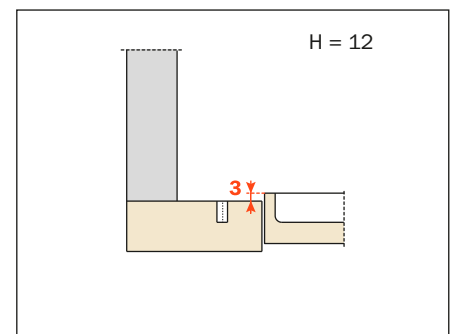
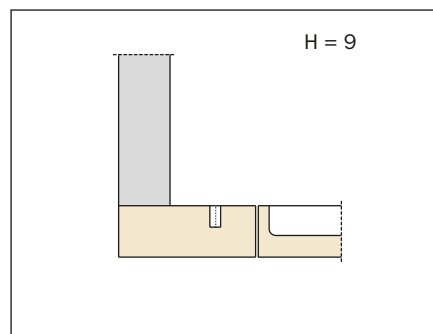
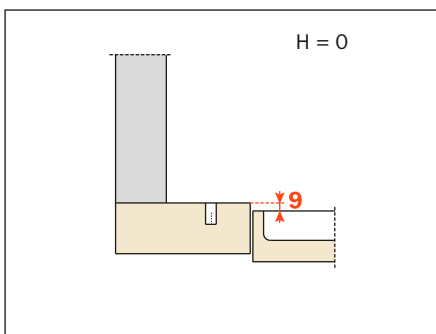



## Silentia - Series 800



Hinges with integrated soft-close mechanism in the hinge cup.

Bright nickel plated steel cup and arm.  
Dimensions of the Ø 35 mm cup.

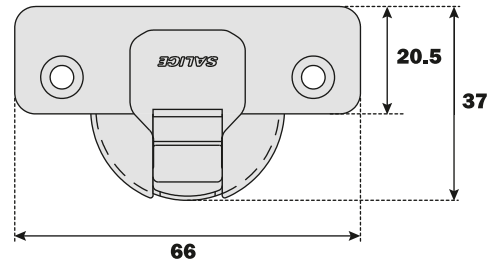

Approx. number of hinges required according to the door dimension and weight.

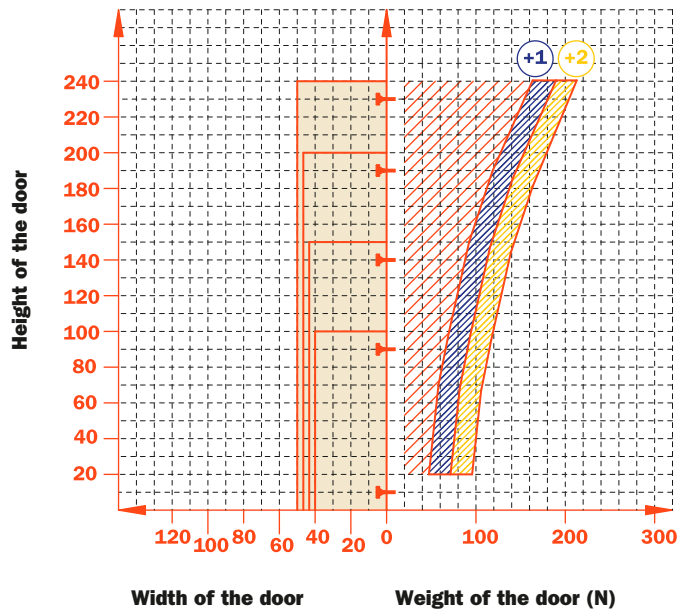



### Adjustments

Side adjustment from -1.5 mm to +4.5 mm.  
Height adjustment  $\pm 2$  mm.  
Depth adjustment from -1.5 mm to +3 mm.

### Mounting plates

Symmetrical and asymmetrical bright nickel plated steel Series 200 mounting plates.  
**NOT COMPATIBLE** with Series 200 mounting plates with negative height.

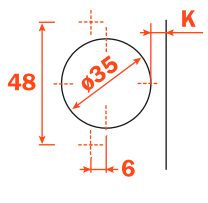
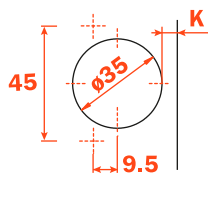
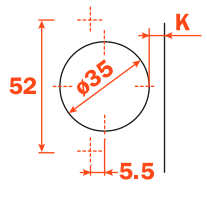
N.B. : Use POZIDRIVE No. 2 screwdrivers for all screws.

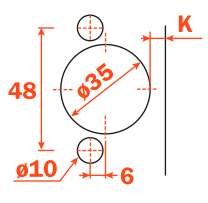
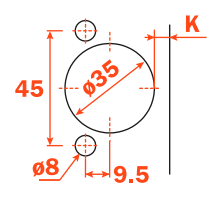
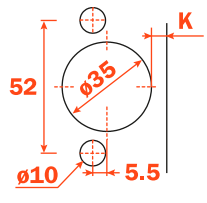
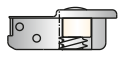
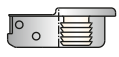
			
Wood screw 	A	P	U
			
Rapido 	6	7	2
Dowel 	B	R	W

Use this table to identify the available drillings and fixings.  
 Fill the third position of the hinge code number with the letter or the number corresponding to your choice. I.e.: C8\_6CD9.

↑  
 Fill this position with the chosen letter or number.

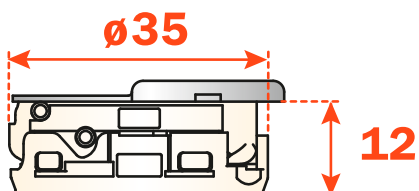

105° opening



**Attention:**  
 it is essential to drill the door as specified for the perfect functioning of the hinge.



**Technical information**

**Hinges with integrated soft-close mechanism in the hinge cup.**

**Hinges for doors of small weight and thickness.  
12 mm deep cup.**

105° opening.  
Possible drilling distance on the door (K): from 3 to 6 mm.  
Compatible with all traditional steel Series 200 mounting plates.

**Space needed to open the door**

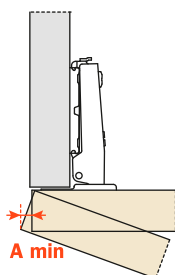

	T=	15	16	17	18	19	20
K=3	<b>A=</b>	1.0	1.0	1.2	1.4	1.6	1.9
K=4	<b>A=</b>	0.9	1.0	1.2	1.3	1.5	1.8
K=5	<b>A=</b>	0.9	1.0	1.1	1.2	1.5	1.8
K=6	<b>A=</b>	0.9	1.0	1.1	1.2	1.4	1.7

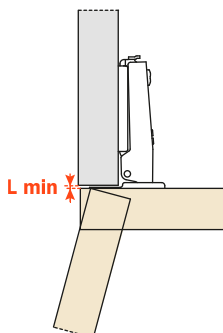

	T=	15	16	17	18	19	20
K=3	<b>L=</b>	0.0	0.0	0.0	0.0	0.1	0.3
K=4	<b>L=</b>	0.4	0.6	0.7	0.9	1.1	1.2
K=5	<b>L=</b>	1.0	1.0	1.2	1.8	2.0	2.0
K=6	<b>L=</b>	1.6	1.8	2.0	2.1	2.3	2.5

**The above values are calculated on the assumption that the doors have square edges. They are reduced if the doors have radiussed edges.**

**Projection of the door**

Projection of the door from the cabinet side at the max. opening. The figures are based on a straight arm hinge, H=0 mm thickness of mounting plate and K value = 3 mm.

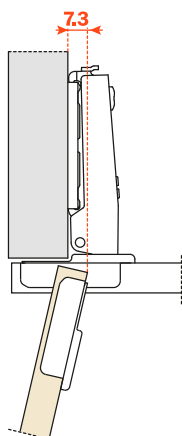

**“C” value**

With this formula you can obtain the max. thickness of the moulded door that can be opened without touching adjacent carcass sides, doors or walls, whilst bearing in mind the above L-K-T values.

$$C = 20.5 + K + A$$

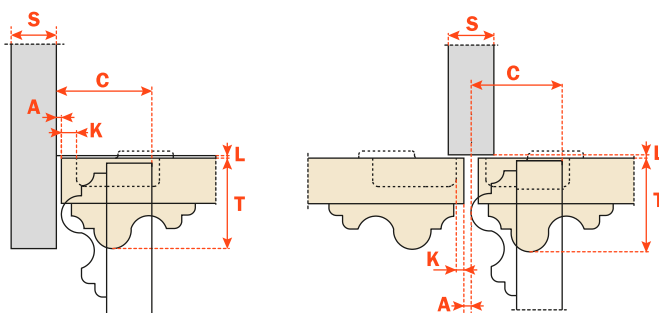



**Packing**

Boxes 300 pcs.  
 Pallets 7.200 pcs.

Use these formulas to determine the type of hinge arm, the drilling distance "K" and the height of the mounting plate "H" which is necessary to solve each application problem.

Use the tables "Drillings and fixings" at page 61 to complete the code number of the desired hinge.

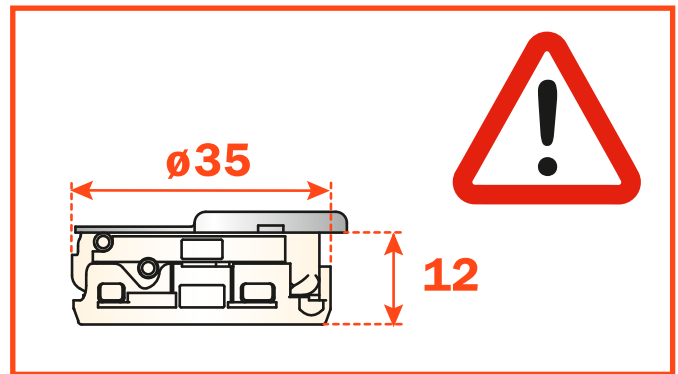
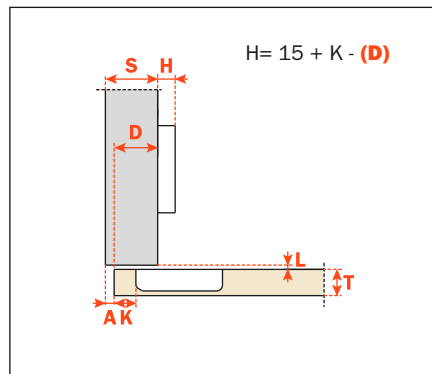
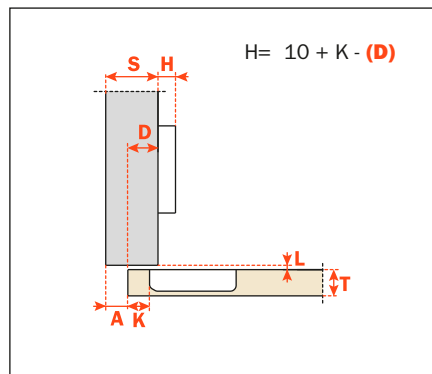
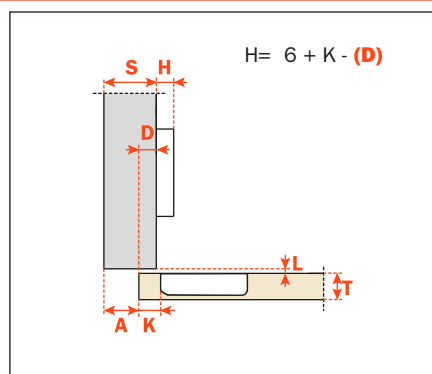
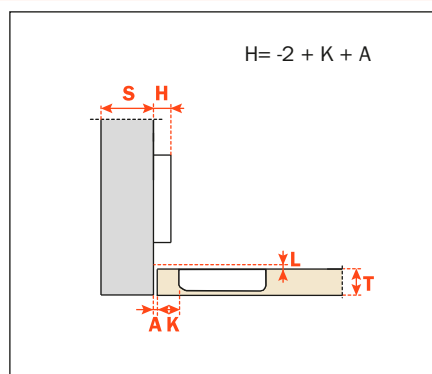
**Arm 0****C8\_6CD9****Arm 5****C8\_6JD9****Arm 9****C8\_6LD9****Arm 17****C8\_6SD9**



## Silentia - Series 900



Hinges with integrated soft-close mechanism in the hinge cup.

Bright nickel plated steel cup and arm.  
Dimensions of the Ø 35 mm cup.

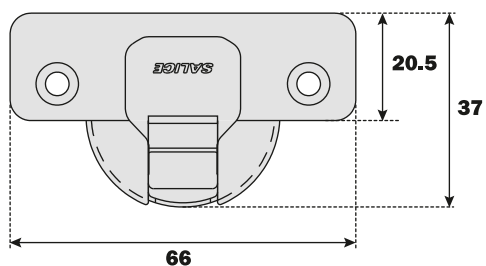

Approx. number of hinges required according to the door dimension and weight.

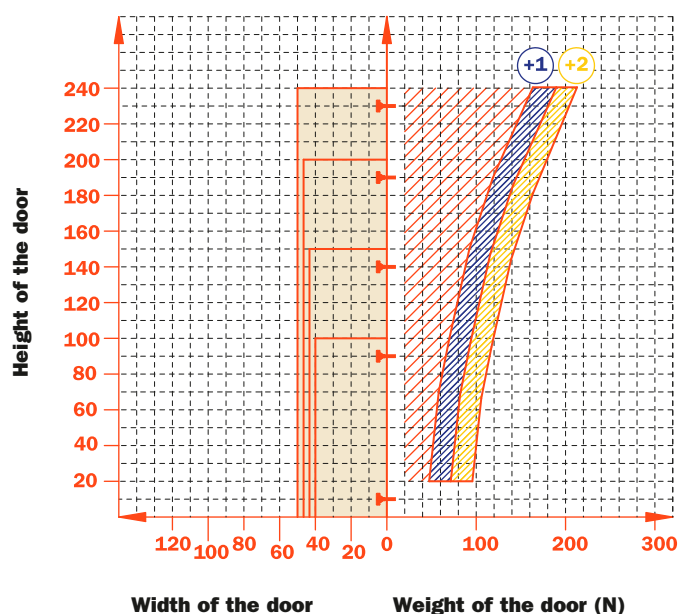



### Adjustments

Side adjustment from -1.5 mm to +4 mm.  
Height adjustment ±2 mm.  
Depth adjustment +2.5 mm.

### Mounting plates

Symmetrical and asymmetrical bright nickel plated steel or die-cast Series 200 mounting plates.  
**NOT COMPATIBLE** with Series 200 mounting plates with negative height.

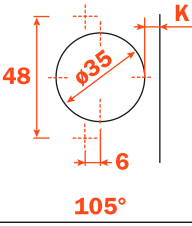
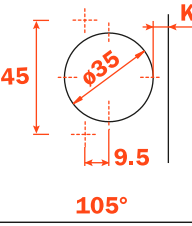
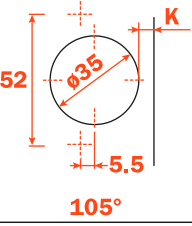
N.B. : Use POZIDRIVE No. 2 screwdrivers for all screws.

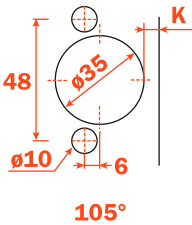
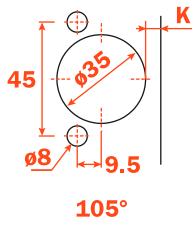
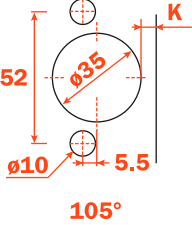
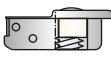
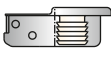
			
Wood screw 	A	P	U
			
Rapido 	6	7	2
Dowel 	B	R	W

Use this table to identify the available drillings and fixings.

Fill the third position of the hinge code number with the letter or the number corresponding to your choice. I.e.: C9\_6CD9.



Fill this position with the chosen letter or number.

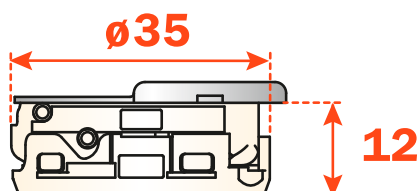

105° opening



**Attention:**

it is essential to drill the door as specified for the perfect functioning of the hinge.



**Technical information**

**Hinges with integrated soft-close mechanism in the hinge cup.**

**Hinges for doors of small weight and thickness.  
12 mm deep cup.**

105° opening.  
Possible drilling distance on the door (K): from 3 to 6 mm.  
Compatible with all traditional Series 200 mounting plates.  
**NOT COMPATIBLE** with Domi snap-on mounting plates.

**Space needed to open the door**

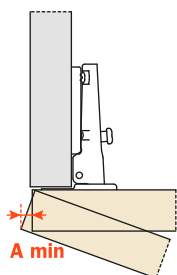

	T=	15	16	17	18	19	20
K=3	<b>A=</b>	1.0	1.0	1.2	1.4	1.6	1.9
K=4	<b>A=</b>	0.9	1.0	1.2	1.3	1.5	1.8
K=5	<b>A=</b>	0.9	1.0	1.1	1.2	1.5	1.8
K=6	<b>A=</b>	0.9	1.0	1.1	1.2	1.4	1.7

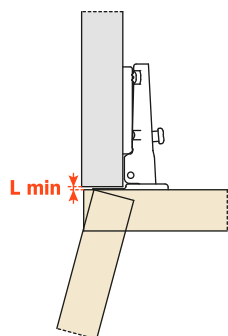

	T=	15	16	17	18	19	20
K=3	<b>L=</b>	0.0	0.0	0.0	0.0	0.1	0.3
K=4	<b>L=</b>	0.4	0.6	0.7	0.9	1.1	1.2
K=5	<b>L=</b>	1.0	1.0	1.2	1.8	2.0	2.0
K=6	<b>L=</b>	1.6	1.8	2.0	2.1	2.3	2.5

**The above values are calculated on the assumption that the doors have square edges. They are reduced if the doors have radiussed edges.**

**Projection of the door**

Projection of the door from the cabinet side at the max. opening. The figures are based on a straight arm hinge, H=0 mm thickness of mounting plate and K value = 3 mm.

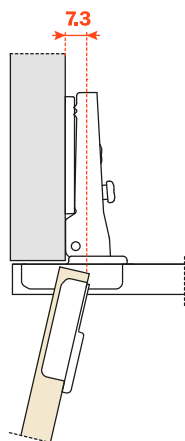

**“C” value**

With this formula you can obtain the max. thickness of the moulded door that can be opened without touching adjacent carcass sides, doors or walls, whilst bearing in mind the above L-K-T values.

$$C = 20.5 + K + A$$

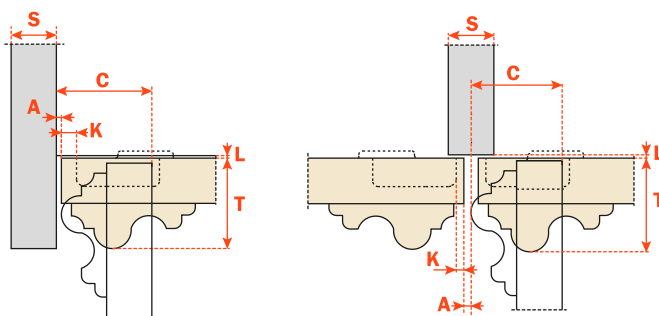



**Packing**

Boxes 300 pcs.  
Pallets 7.200 pcs.

Use these formulas to determine the type of hinge arm, the drilling distance "K" and the height of the mounting plate "H" which is necessary to solve each application problem.

Use the tables "Drillings and fixings" at page 67 to complete the code number of the desired hinge.

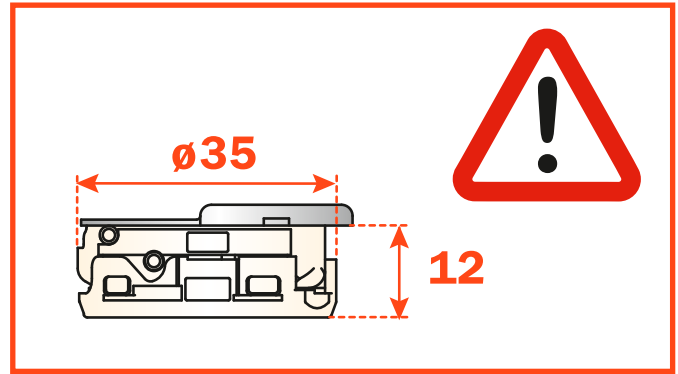
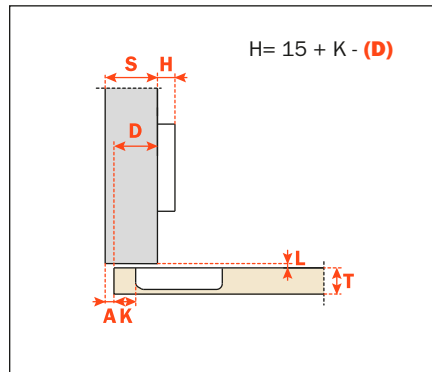
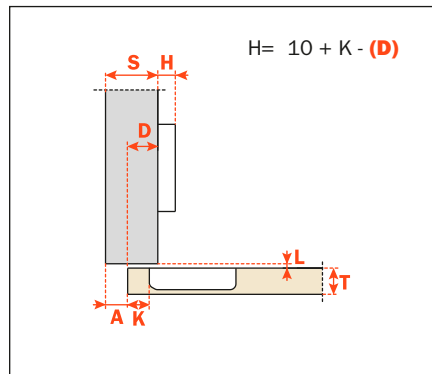
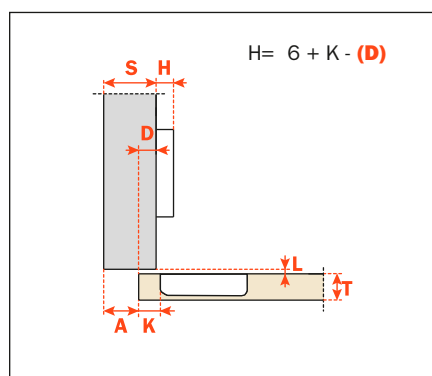
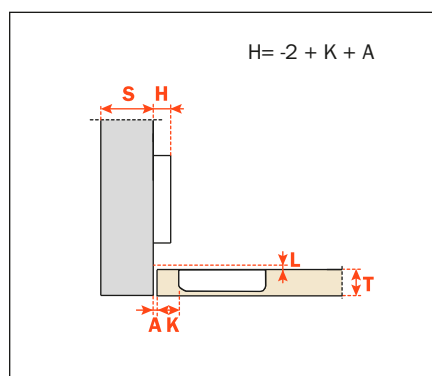
**Arm 0****C9\_6CD9****Arm 5****C9\_6JD9****Arm 9****C9\_6LD9****Arm 17****C9\_6SD9**



## Series 100



**Hinges for thinner door.**

**Bright nickel plated steel cup and arm.  
Dimensions of the Ø 35 mm cup.**

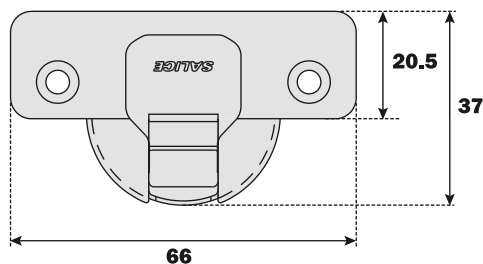

Constant "L" value of 0.7 mm (it does not change during side adjustment).

Approx. number of hinges required according to the door dimension and weight.

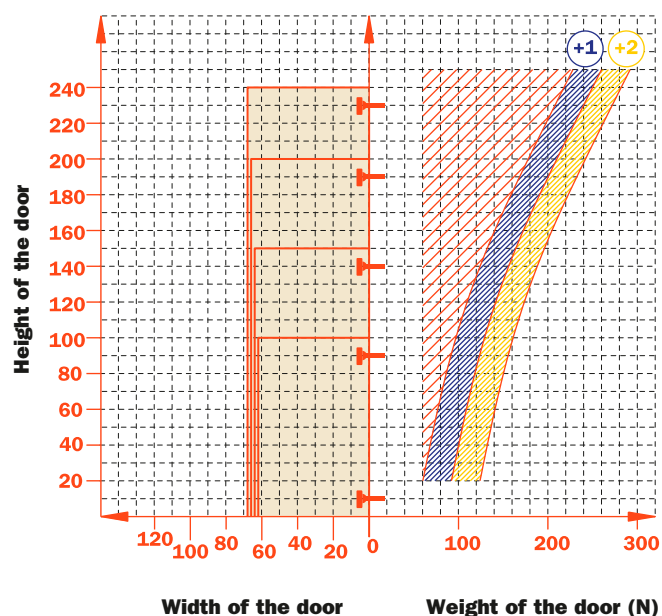

**Adjustments**

Compensated side adjustment from -1.5 mm to +4.5 mm.  
Height adjustment  $\pm 2$  mm.  
Depth adjustment with Series 200 mounting plates +2.8 mm.  
Depth adjustment with Domi snap-on mounting plates from -0.5 mm to +2.8 mm.  
Anti-sliding safety stop.

**Mounting plates**

Symmetrical and asymmetrical bright nickel plated steel or die-cast Series 200 mounting plates.  
Snap-on assembly on Domi mounting plates.  
Positioning with pre-determined stop on traditional Series 200 mounting plates.

N.B. : Use POZIDRIVE No. 2 screwdrivers for all screws.

<b>Wood screw</b>		<b>105°</b>	<b>155°</b>	
		<b>A</b>	<b>A</b>	
		<b>105°</b>	<b>155°</b>	
		<b>P</b>	<b>P</b>	
		<b>105°</b>	<b>155°</b>	
		<b>U</b>	<b>U</b>	

<b>Dowel</b>		<b>105°</b>	<b>155°</b>
		<b>B</b>	<b>B</b>

Use this table to identify the available drillings and fixings.  
 Fill the third position of the hinge code number with the letter or the number corresponding to your choice. I.e.: C1\_6A99.

↑  
 Fill this position with the chosen letter or number.



**Technical information**

**For min. 10 mm thick doors.**  
 8 mm deep metal cup.  
 105° opening.  
 Possible drilling distance on the door (K): from 3 to 6 mm.  
 Compatible with all traditional Series 200 mounting plates and with all Domi snap-on mounting plates.

**Space needed to open the door**

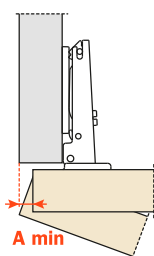

	T=	10	11	12	13	14	15	16	17	18	19	20
K=3	<b>A=</b>	0.2	0.3	0.4	0.6	0.8	1.0	1.3	1.6	1.9	2.3	2.7
K=4	<b>A=</b>	0.2	0.3	0.4	0.6	0.8	1.0	1.3	1.6	1.9	2.2	2.6
K=5	<b>A=</b>	0.1	0.3	0.4	0.6	0.8	1.0	1.2	1.5	1.8	2.1	2.5
K=6	<b>A=</b>	0.1	0.2	0.4	0.5	0.7	1.0	1.2	1.5	1.8	2.1	2.4

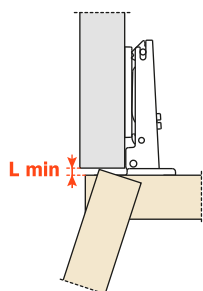

	T=	10	11	12	13	14	15	16	17	18	19	20
K=3	<b>L=</b>	0.0	0.0	0.0	0.0	0.0	0.0	0.0	0.0	0.0	0.1	0.3
K=4	<b>L=</b>	0.0	0.0	0.0	0.0	0.2	0.4	0.6	0.7	0.9	1.1	1.2
K=5	<b>L=</b>	0.5	0.7	0.9	1.0	1.2	1.4	1.5	1.7	1.9	2.1	2.2
K=6	<b>L=</b>	1.5	1.7	1.8	2.0	2.2	2.4	2.5	2.7	2.9	3.1	3.2

**The above values are calculated on the assumption that the doors have square edges. They are reduced if the doors have radiussed edges.**

**Projection of the door**

Projection of the door from the cabinet side at the max. opening. The figures are based on a straight arm hinge, H=0 mm thickness of mounting plate and K value = 3 mm.

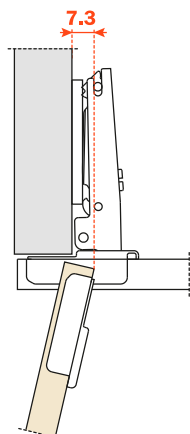

**“C” value**

With this formula you can obtain the max. thickness of the moulded door that can be opened without touching adjacent carcass sides, doors or walls, whilst bearing in mind the above L-K-T values.

$$C = 20.5 + K + A$$

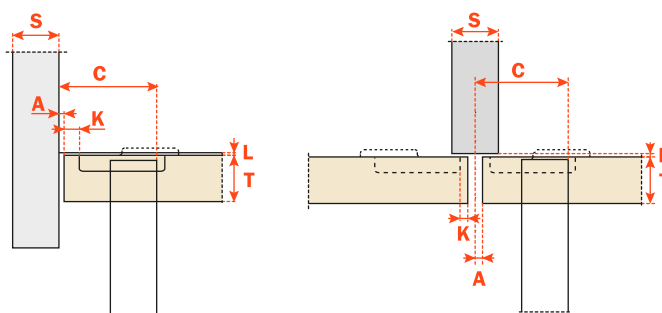



**Packing**

Boxes 300 pcs.  
Pallets 7.200 pcs.

**CA** sprung hinge

**CL** unsprung hinge

Use these formulas to determine the type of hinge arm, the drilling distance "K" and the height of the mounting plate "H" which is necessary to solve each application problem.

Use the tables "Drillings and fixings" at page 73 to complete the code number of the desired hinge.

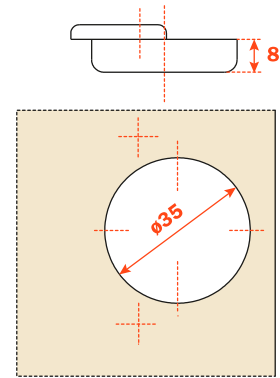
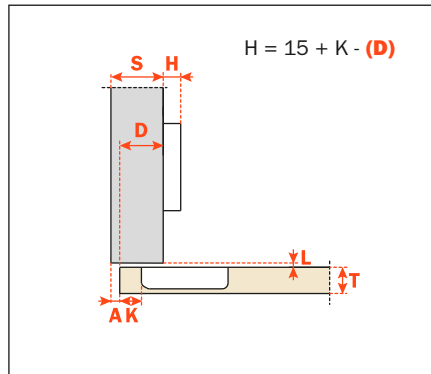
**Arm 0**

**CA - C1\_6A99**

**CL - C1\_4A99**

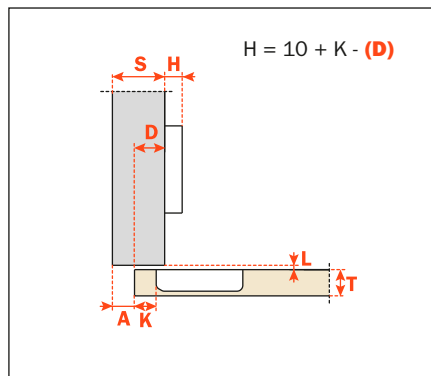
**Arm 5**

**CA - C1\_6D99**

**CL - C1\_4D99**

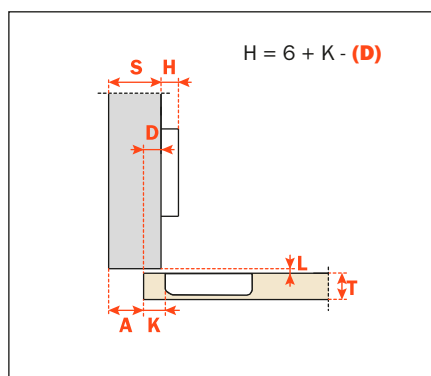
**Arm 9**

**CA - C1\_6G99**

**CL - C1\_4G99**

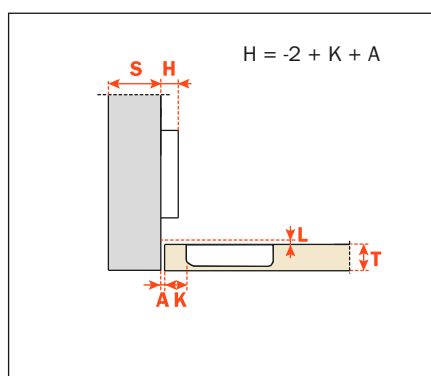
**Arm 17**

**CA - C1\_6P99**

**CL - C1\_4P99**

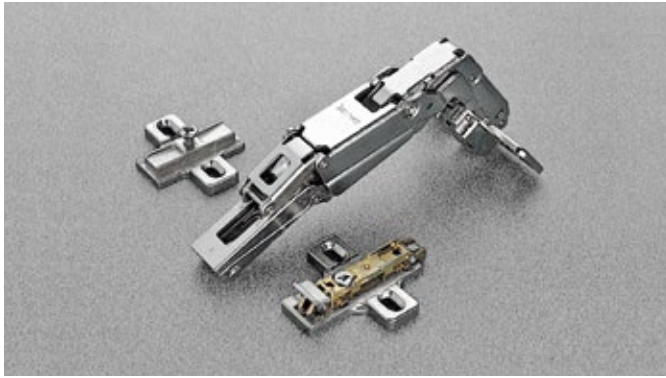

**Technical information**

**For min. 10 mm thick doors.**

8 mm deep die-cast cup.

155° opening.

Possible drilling distance on the door (K): from 3 to 8 mm.

Compatible with all traditional Series 200 mounting plates and with all Domi snap-on mounting plates.

**Space needed to open the door**

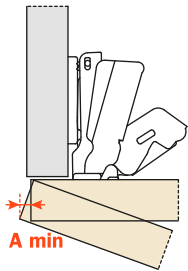

T=	16	18	20	22
K=3	<b>A=</b> 0.0	0.0	0.3	1.2
K=4	<b>A=</b> 0.0	0.4	0.4	1.3
K=5	<b>A=</b> 0.0	0.1	0.5	1.6
K=6	<b>A=</b> 0.0	0.1	1.2	3.0
K=7	<b>A=</b> 0.0	0.1	0.7	2.5
K=8	<b>A=</b> 0.0	0.1	0.6	1.9

**The above values are calculated on the assumption that the doors have square edges. They are reduced if the doors have radiussed edges.**

**“C” value**

For spaces with removable components. The door combined with a mounting plate H=0 opens at 90° with lateral door protrusion of 2 mm.

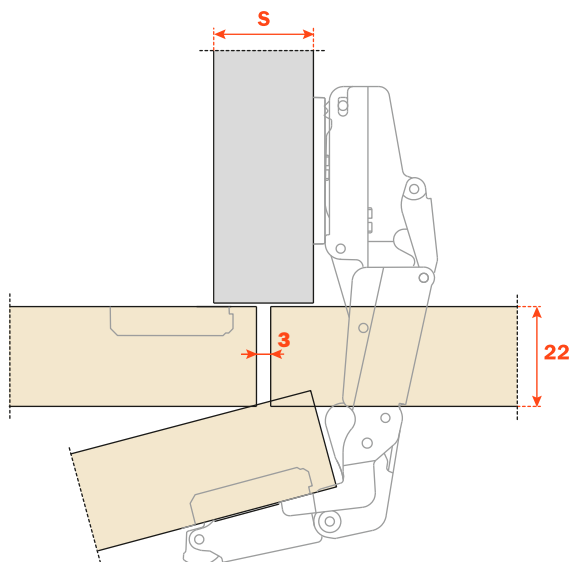
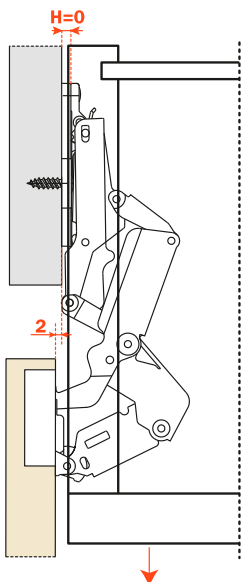

**Packing**

Boxes 100 pcs.  
Pallets 2.400 pcs.

**CA sprung hinge**

Use these formulas to determine the type of hinge arm, the drilling distance "K" and the height of the mounting plate "H" which is necessary to solve each application problem.

To limit the opening of the hinge, see page 362 chapter "Accessories".

Use the tables "Drillings and fixings" at page 73 to complete the code number of the desired hinge.

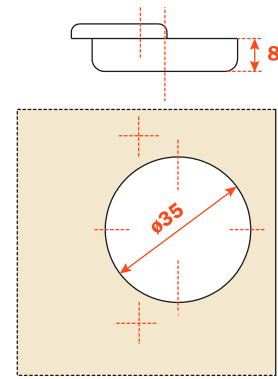
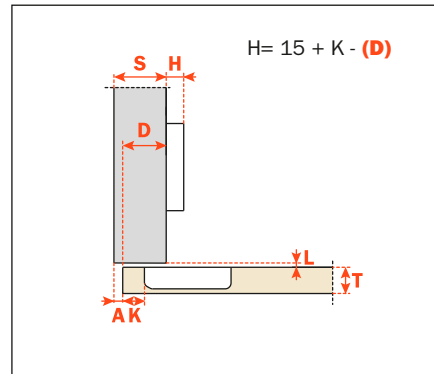
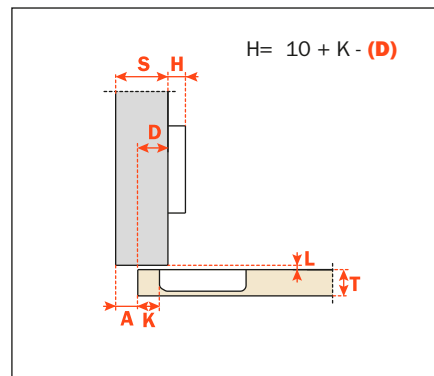
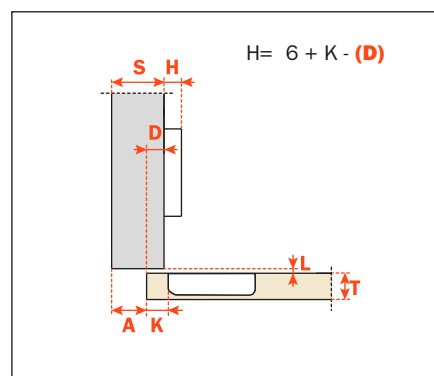
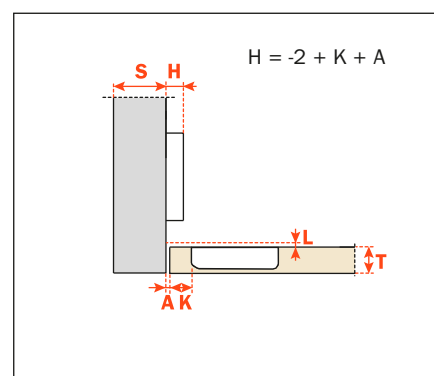
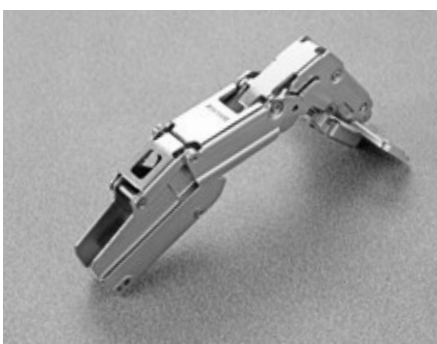
**Arm 0****CA - C2\_MA99****Arm 5****CA - C2\_MD99****Arm 9****CA - C2\_MG99****Arm 17****CA - C2\_MP99**



**Technical information**

**Hinges for wooden doors with positive angled assembly.  
For min. 10 mm thick doors.**

8mm deep metal cup.

105° opening.

Possible drilling distance on the door (K): from 3 to 6 mm.

Compatible with all traditional Series 200 mounting plates and with all Domi snap-on mounting plates.

**Packing**

Boxes 150 pcs.

Pallets 3.600 pcs.

**CA** sprung hinge

The solution of assembly problems where doors are mounted at a positive angle requires the verification of drilling distances by a practical trial. Please do not hesitate to consult our technical support department for assistance.

Use the tables "Drillings and fixings" at page 73 to complete the code number of the desired hinge.

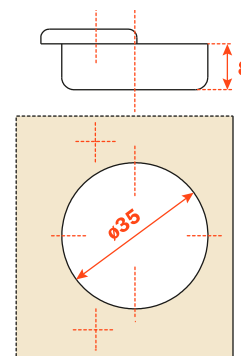

Arm **15°**

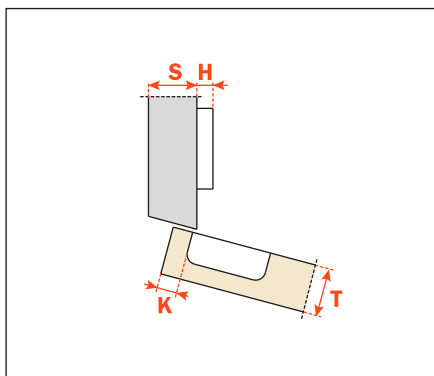

**CA - C1\_6Z99**

Arm **24°**

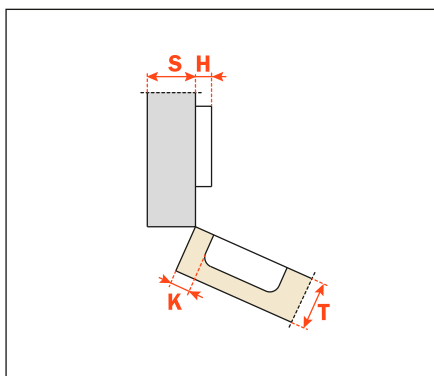

**CA - C1\_6U99**

Arm **30°**

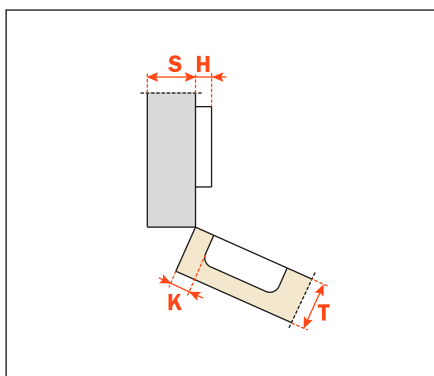

**CA - C1\_6E99**

Arm 30°

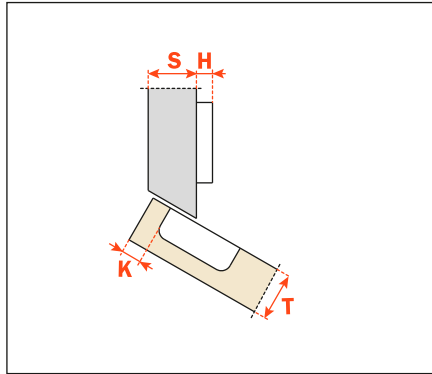

**CA - C1\_6T99**

Arm 37°

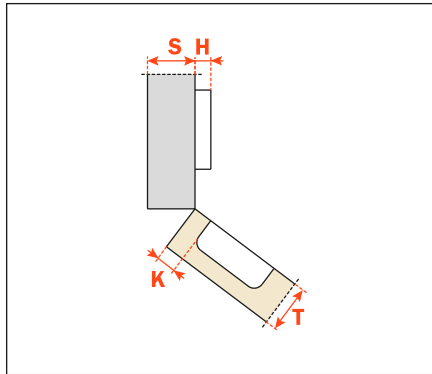

**CA - C1\_6K99**

Arm 45°

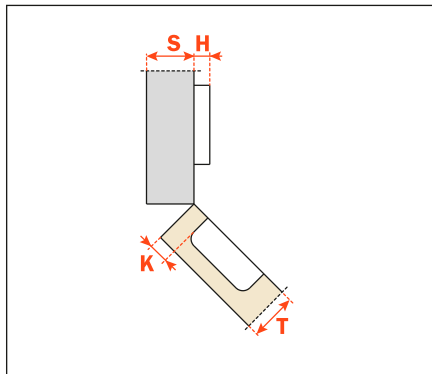

**CA - C1\_6M99**

Arm 45°

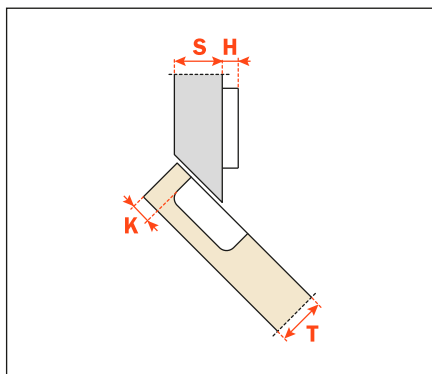

**CA - C1\_6V99**

Arm 45°

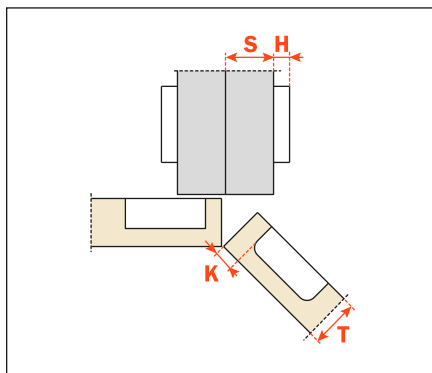

**CA - C1\_6M99AC**





**Technical information**

**Crampon hinges.**  
**For cabinet sides with 37x32 mm standard drilling.**  
**For min. 10 mm thick doors.**  
 8 mm deep metal cup.  
 105° opening.  
 Possible drilling distance on the door (K): from 3 to 6 mm.  
 Compatible with all traditional Series 200 mounting plates and with all Domi snap-on mounting plates.

**Packing**

Boxes 150 pcs.  
 Pallets 3.600 pcs.

**CA sprung hinge**

**E min:**

61 mm for Series 200 mounting plates.  
 70 mm for Domi snap-on mounting plates.  
 74 mm for Domi snap-on mounting plates with back cam.

Use the tables "Drillings and fixings" at page 73 to complete the code number of the desired hinge.

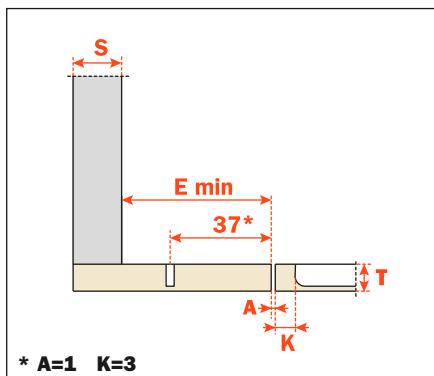
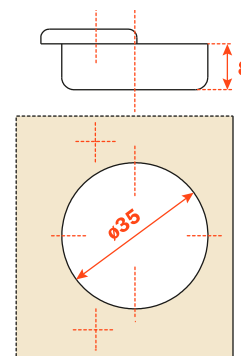

**CA - C1\_6N99AC**

Heights of mounting plates for every assembly.

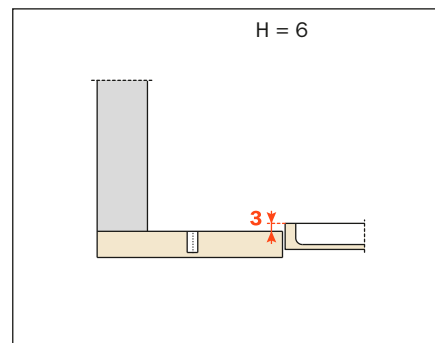
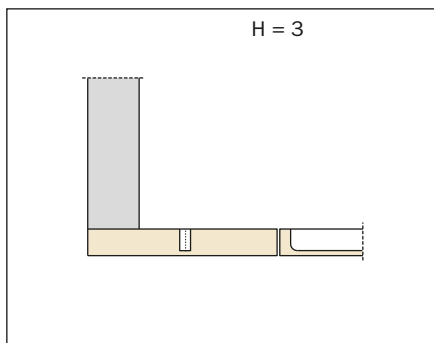
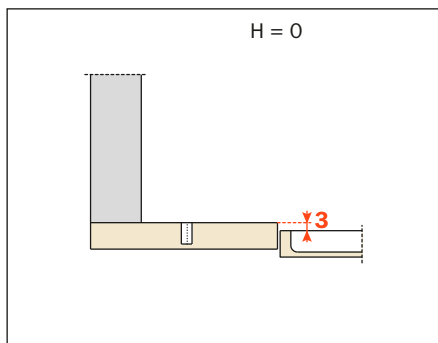



## Series 200



Series 200

The Series 200 make up an integrated system of hinges developed to provide a solution to any situation involving concealed hinges.

Bright nickel plated steel cup and arm.

Dimensions of the Ø 35 mm cup.

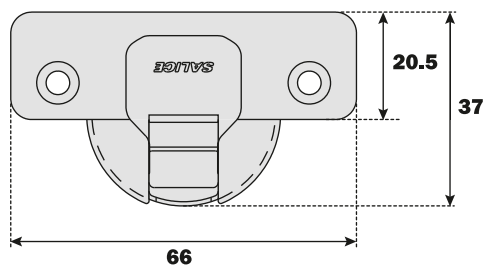

Constant "L" value of 0.7 mm (it does not change during side adjustment).

Approx. number of hinges required according to the door dimension and weight.

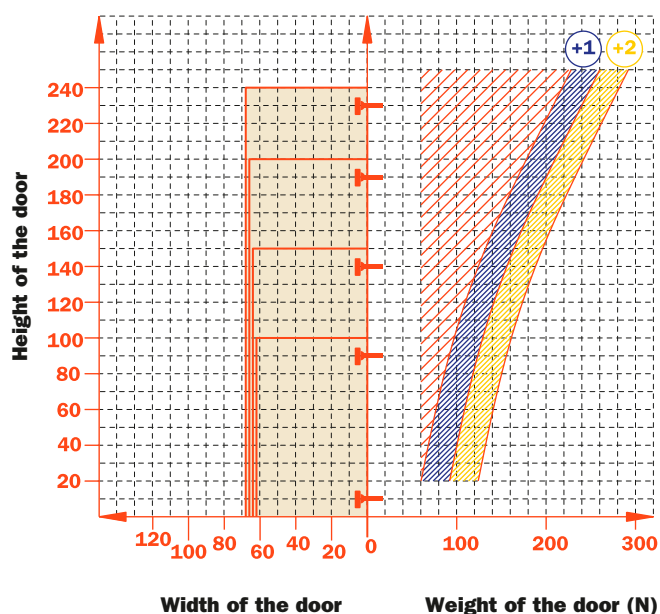

## Adjustments

Compensating side adjustment from -1.5 mm to +4.5 mm.  
 Height adjustment  $\pm 2$  mm.  
 Depth adjustment with Series 200 mounting plates +2.8 mm.  
 Depth adjustment with Domi snap-on mounting plates from -0.5 mm to +2.8 mm.  
 Anti-sliding safety stop.

## Mounting plates

Symmetrical and asymmetrical bright nickel plated steel or die-cast Series 200 mounting plates.  
 Snap-on assembly on Domi mounting plates.  
 Positioning with pre-determined stop on traditional Series 200 mounting plates.

N.B. : Use POZIDRIVE No. 2 screwdrivers for all screws.

## Drillings and fixings

<b>Wood screw</b>		A	A	A	A	P	P	P	P	U	U	U	U
<b>Rapido</b>		6	6	6	6	7	7	7	7	2	2	2	2
<b>Dowel</b>		B	B	B	B	R	R	R	R	W	W	W	W
<b>Logica</b>		I	I	I	I	J	J	J	J	Q	Q	Q	Q

**Use this table to identify the available drillings and fixings.**

**Fill the third position of the hinge code number with the letter or the number corresponding to your choice. I.e.: C2\_BA99.**

↑  
Fill this position with the chosen letter or number.

# Series 200 - For thicker doors - 94° opening



## Technical information

**For thicker doors, max. 35 mm, with special profiles.**

11 mm deep metal cup.

94° opening.

Possible drilling distance on the door (K): from 3 to 9 mm.

Compatible with all traditional Series 200 mounting plates and with all Domi snap-on mounting plates.

## Space needed to open the door

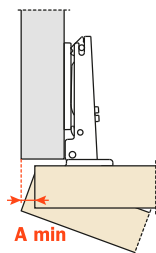

T=	19	20	21	22	23	24	25	26	27	28	29	30	31	32	33	34	35
K=3 <b>A=</b>	0.1	0.2	0.3	0.4	0.5	0.7	0.8	1.0	1.6	2.6	3.5	4.5	5.4	6.4	7.4	8.3	9.3
K=4 <b>A=</b>	0.1	0.2	0.3	0.4	0.5	0.7	0.8	1.0	1.2	1.9	2.8	3.8	4.7	5.7	6.6	7.6	8.6
K=5 <b>A=</b>	0.1	0.2	0.3	0.4	0.5	0.7	0.8	1.0	1.2	1.4	2.2	3.1	4.1	5.0	5.9	6.9	7.8
K=6 <b>A=</b>	0.1	0.2	0.3	0.4	0.5	0.6	0.8	1.0	1.2	1.4	1.7	2.6	3.5	4.4	5.3	6.2	7.2
K=7 <b>A=</b>	0.1	0.2	0.3	0.4	0.5	0.6	0.8	1.0	1.1	1.3	1.6	2.1	3.0	3.8	4.7	5.6	6.5
K=8 <b>A=</b>	0.1	0.2	0.3	0.4	0.5	0.6	0.8	0.9	1.1	1.3	1.6	1.8	2.5	3.3	4.2	5.1	6.0
K=9 <b>A=</b>	0.1	0.2	0.3	0.4	0.5	0.6	0.8	0.9	1.1	1.3	1.5	1.8	2.1	2.9	3.7	4.6	5.4

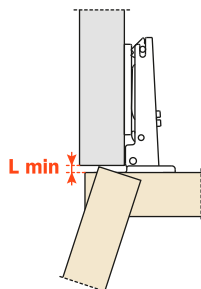

K=	3	4	5	6	7	8	9
<b>L=</b>	0.0	0.0	0.0	0.0	0.0	0.3	1.3

The above values are calculated on the assumption that the doors have square edges. They are reduced if the doors have radiused edges.

## Projection of the door

Projection of the door from the cabinet side at the max. opening. The figures are based on a straight arm hinge, H=0 mm thickness of mounting plate and K value = 3 mm.

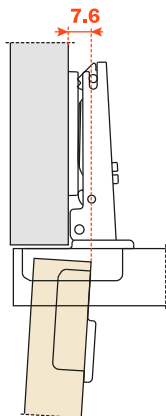

## “C” value

With this formula you can obtain the max. thickness of the moulded door that can be opened without touching adjacent carcass sides, doors or walls, whilst bearing in mind the above L-K-T values.

$$C = 23 + K + A$$

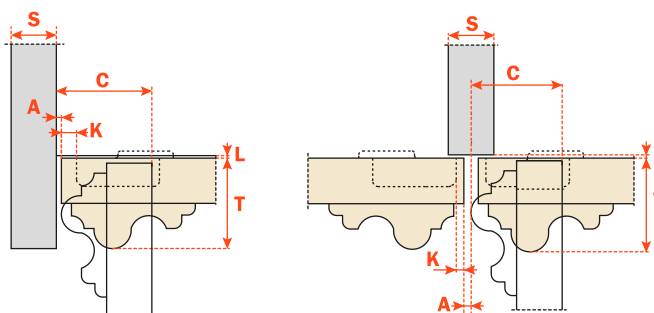

**Packing**

Boxes 300 pcs.  
Pallets 7.200 pcs.

**CA** sprung hinge

Use these formulas to determine the type of hinge arm, the drilling distance "K" and the height of the mounting plate "H" which is necessary to solve each application problem.

Use the tables "Drillings and fixings" at page 83 to complete the code number of the desired hinge.

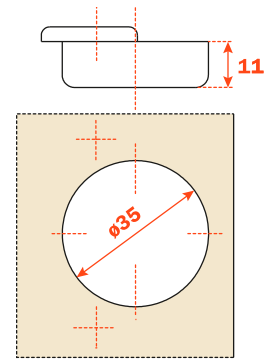

Arm 0

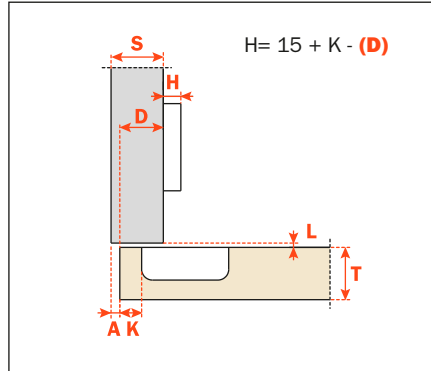

**CA - C2\_BA99**

Arm 5

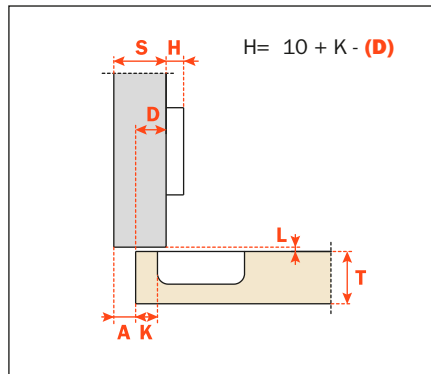

**CA - C2\_BD99**

Arm 9

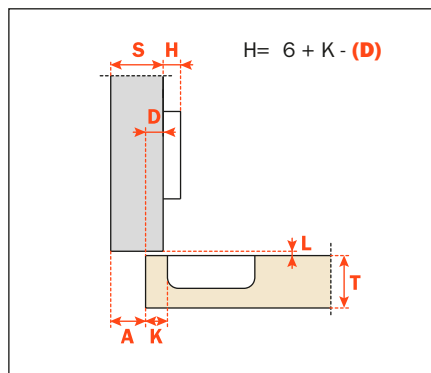

**CA - C2\_BG99**

Arm 17

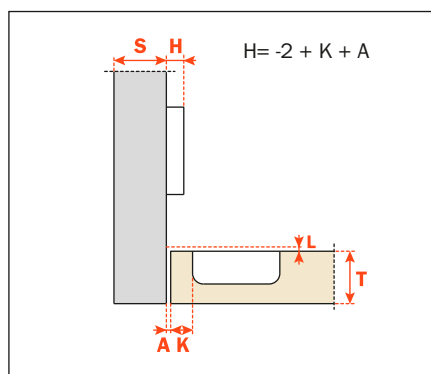

**CA - C2\_BP99**



**Technical information**

**When a greater opening angle is required.**

11 mm deep metal cup.

110° opening.

Possible drilling distance on the door (K): from 3 to 6 mm.

Compatible with all traditional Series 200 mounting plates and with all Domi snap-on mounting plates.

**Space needed to open the door**

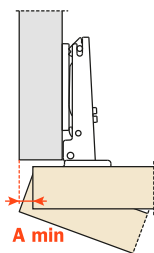

	T=	16	17	18	19	20	21	22	23	24	25	26
K=3	<b>A=</b>	0.5	0.7	0.9	1.2	1.5	1.8	2.4	3.7	5.1	6.5	7.8
K=4	<b>A=</b>	0.5	0.7	0.9	1.2	1.5	1.8	2.1	2.7	4.1	5.5	6.8
K=5	<b>A=</b>	0.5	0.7	0.9	1.2	1.5	1.8	2.1	2.6	3.1	4.1	5.4
K=6	<b>A=</b>	0.5	0.7	0.9	1.2	1.5	1.8	2.1	2.5	3.0	3.5	4.4

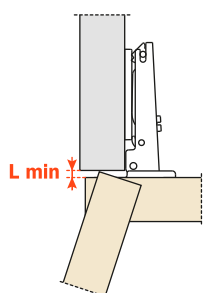

	T=	16	17	18	19	20	21	22	23	24	25	26
K=3	<b>L=</b>	0.0	0.0	0.0	0.0	0.2	0.5	0.8	1.1	1.4	1.7	1.9
K=4	<b>L=</b>	0.0	0.0	0.3	0.6	0.9	1.2	1.4	1.7	2.0	2.3	2.6
K=5	<b>L=</b>	1.1	1.3	1.6	1.8	2.1	2.3	2.6	2.9	3.1	3.4	3.6
K=6	<b>L=</b>	2.0	2.3	2.5	2.8	3.1	3.3	3.6	3.8	4.1	4.3	4.6

**The above values are calculated on the assumption that the doors have square edges. They are reduced if the doors have radiussed edges.**

**Projection of the door**

Projection of the door from the cabinet side at the max. opening. The figures are based on a straight arm hinge, H=0 mm thickness of mounting plate and K value = 3 mm.

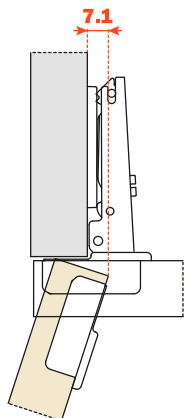

**“C” value**

With this formula you can obtain the max. thickness of the moulded door that can be opened without touching adjacent carcass sides, doors or walls, whilst bearing in mind the above L-K-T values.

$C = 20 + K + A$

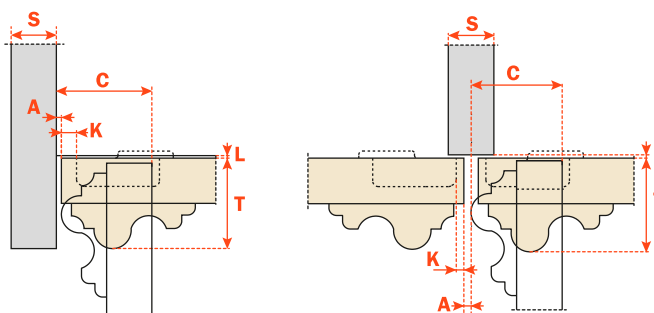



**Packing**

Boxes 300 pcs.  
Pallets 7.200 pcs.

**CA** sprung hinge  
**CL** unsprung hinge

Use these formulas to determine the type of hinge arm, the drilling distance "K" and the height of the mounting plate "H" which is necessary to solve each application problem.

Use the tables "Drillings and fixings" at page 83 to complete the code number of the desired hinge.

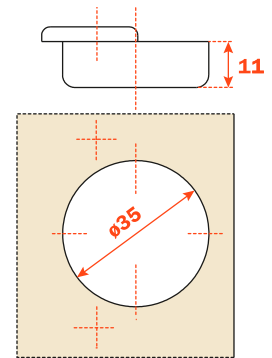
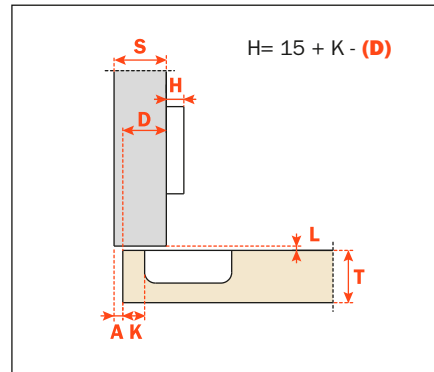
**Arm 0**

**CA - C2\_6A99**  
**CL - C2\_4A99**

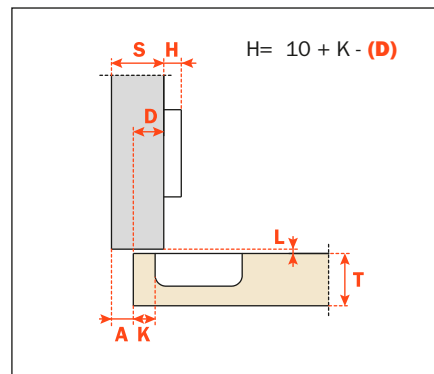
**Arm 5**

**CA - C2\_6D99**  
**CL - C2\_4D99**

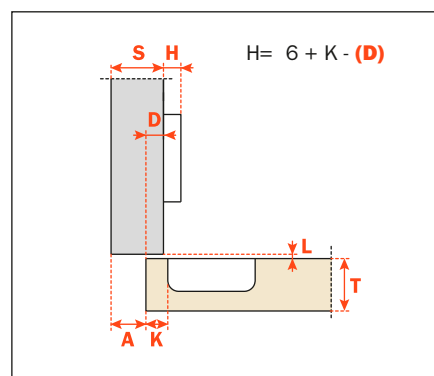
**Arm 9**

**CA - C2\_6G99**  
**CL - C2\_4G99**

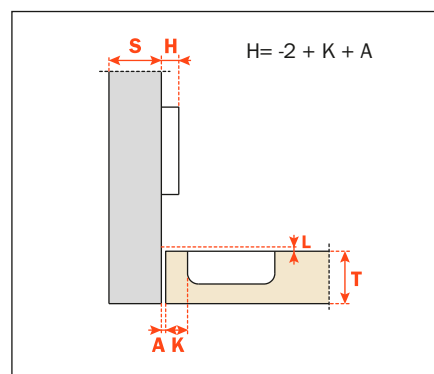
**Arm 17**

**CA - C2\_6P99**  
**CL - C2\_4P99**



**Technical information**

**When a greater opening angle is required.**

11 mm deep metal cup.

120° opening.

Possible drilling distance on the door (K): from 3 to 6 mm.

Compatible with all traditional Series 200 mounting plates and with all Domi snap-on mounting plates.

**Space needed to open the door**

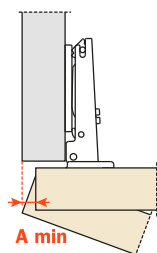

	T=	16	17	18	19	20	21	22	23	24	25	26
K=3	<b>A=</b>	1.0	1.3	1.6	1.9	2.2	3.5	5.0	6.5	8.1	9.6	11.2
K=4	<b>A=</b>	1.0	1.3	1.5	1.9	2.2	2.5	4.0	5.5	7.1	8.6	10.2
K=5	<b>A=</b>	1.0	1.2	1.5	1.8	2.1	2.5	3.0	4.5	6.1	7.6	9.2
K=6	<b>A=</b>	1.0	1.2	1.5	1.8	2.1	2.4	2.8	3.5	5.1	6.6	8.1

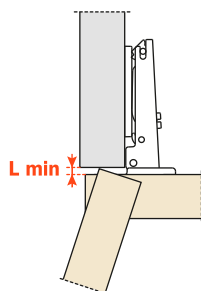

	T=	16	17	18	19	20	21	22	23	24	25	26
K=3	<b>L=</b>	0.0	0.0	0.0	0.0	0.1	0.5	0.9	1.3	1.7	2.1	2.5
K=4	<b>L=</b>	0.0	0.0	0.2	0.6	1.0	1.4	1.8	2.2	2.6	3.1	3.5
K=5	<b>L=</b>	0.3	0.7	1.1	1.5	1.9	2.3	2.8	3.2	3.6	4.0	4.4
K=6	<b>L=</b>	1.2	1.6	2.0	2.4	2.8	3.3	3.7	4.1	4.5	4.9	5.3

**The above values are calculated on the assumption that the doors have square edges. They are reduced if the doors have radiussed edges.**

**Projection of the door**

Projection of the door from the cabinet side at the max. opening. The figures are based on a straight arm hinge, H=0 mm thickness of mounting plate and K value = 3 mm.

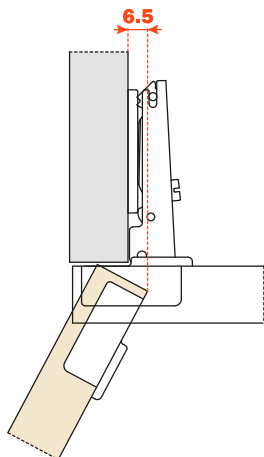

**“C” value**

With this formula you can obtain the max. thickness of the moulded door that can be opened without touching adjacent carcass sides, doors or walls, whilst bearing in mind the above L-K-T values.

$$C = 20 + K + A$$

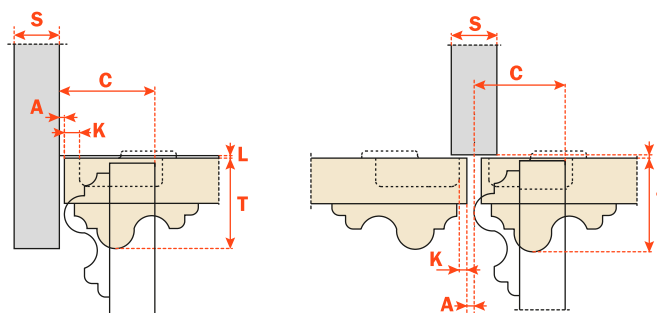

**Packing**

Boxes 300 pcs.  
Pallets 7.200 pcs.

**CA** sprung hinge

**CL** unsprung hinge

Use these formulas to determine the type of hinge arm, the drilling distance "K" and the height of the mounting plate "H" which is necessary to solve each application problem.

Use the tables "Drillings and fixings" at page 83 to complete the code number of the desired hinge.

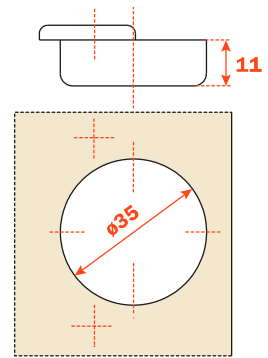
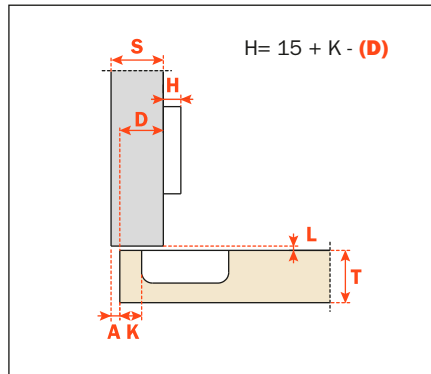
**Arm 0**

**CA - C2\_9A99**

**CL - C2\_8A99**

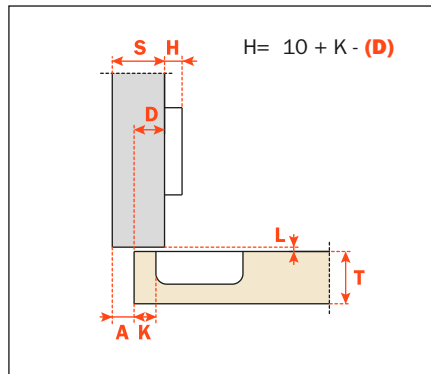
**Arm 5**

**CA - C2\_9D99**

**CL - C2\_8D99**

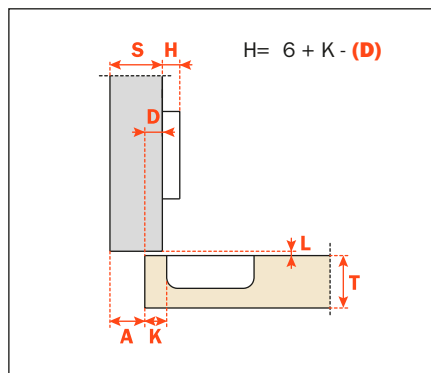
**Arm 9**

**CA - C2\_9G99**

**CL - C2\_8G99**

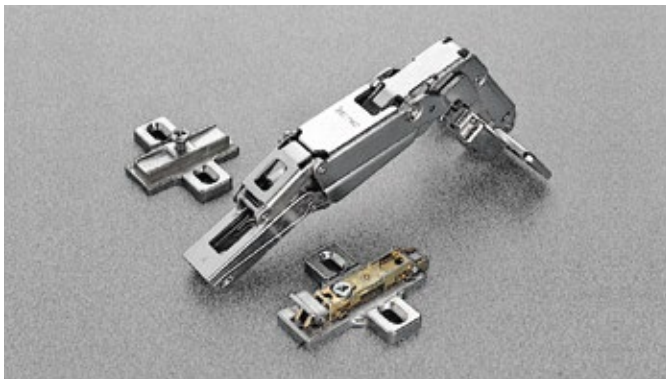

**Technical information**

**For min.10 mm thick doors.**

8 mm deep die-cast cup.

155° opening.

Possible drilling distance on the door (K) : from 3 to 8 mm.

Compatible with all traditional Series 200 mounting plates and with all Domi snap-on mounting plates.

**Space needed to open the door**

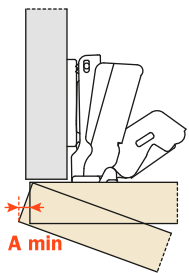

T=	16	18	20	22
K=3	<b>A=</b> 0.0	0.0	0.3	1.2
K=4	<b>A=</b> 0.0	0.4	0.4	1.3
K=5	<b>A=</b> 0.0	0.1	0.5	1.6
K=6	<b>A=</b> 0.0	0.1	1.2	3.0
K=7	<b>A=</b> 0.0	0.1	0.7	2.5
K=8	<b>A=</b> 0.0	0.1	0.6	1.9

**The above values are calculated on the assumption that the doors have square edges. They are reduced if the doors have radiussed edges.**

**“C” value**

For spaces with removable components. The door combined with a mounting plate H=0 opens at 90° with lateral door protrusion of 2 mm.

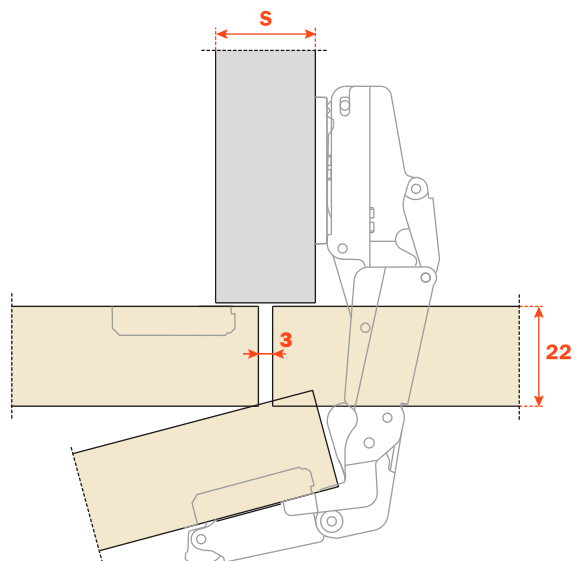
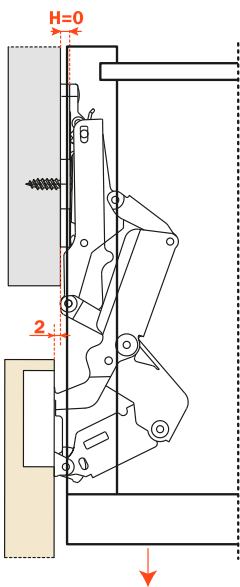

**Packing**

Boxes 100 pcs.  
Pallets 2.400 pcs.

**CA sprung hinge**

Use these formulas to determine the type of hinge arm, the drilling distance "K" and the height of the mounting plate "H" which is necessary to solve each application problem.

To limit the opening of the hinge, see page 362 chapter "Accessories".

Use the tables "Drillings and fixings" at page 83 to complete the code number of the desired hinge.

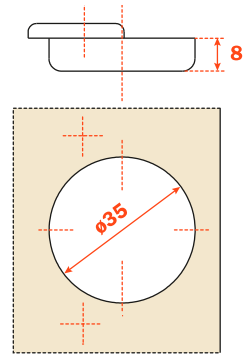
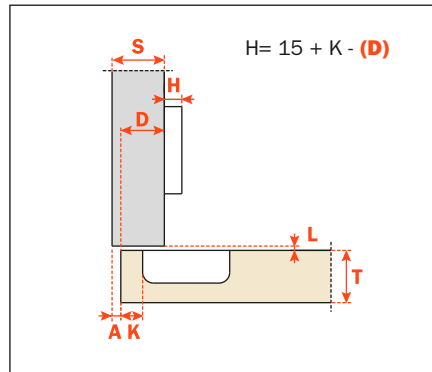
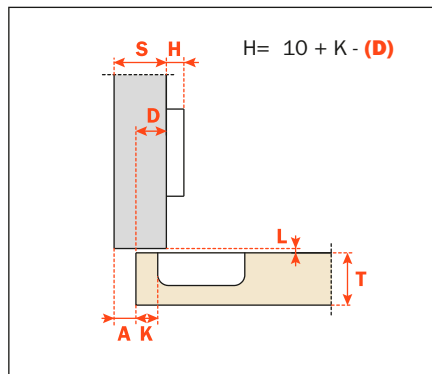
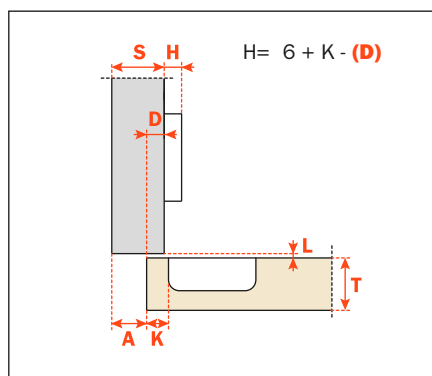
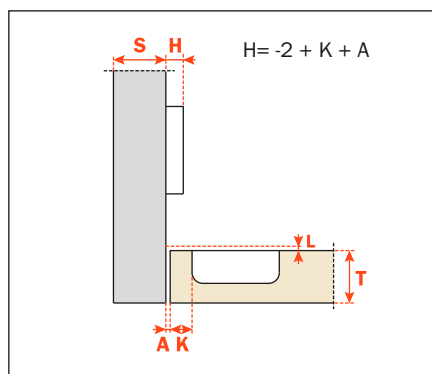
**Arm 0****CA - C2\_MA99****Arm 5****CA - C2\_MD99****Arm 9****CA - C2\_MG99****Arm 17****CA - C2\_MP99**

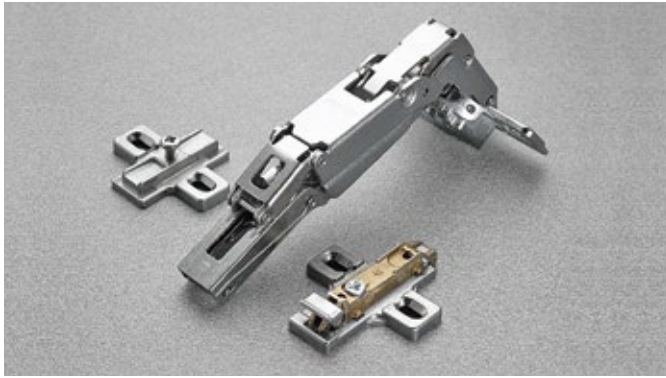

**Technical information**

**For thicker doors max. 35 mm.**  
**Hinge with greater opening angle and reduced operating profile.**  
 11 mm deep die-cast cup.  
 155° opening.  
 Possible drilling distance on the door (K): from 3 to 9 mm.  
 Compatible with all traditional Series 200 mounting plates and with all Domi snap-on mounting plates.

**Space needed to open the door**

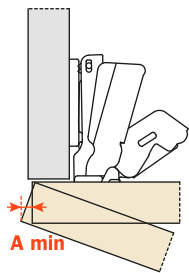

T=	26	27	28	29	30	31	32	33	34	35
K=3	<b>A=</b> 0.0	0.0	0.0	0.8	3.0	4.8	7.1	11.7	16.4	20.7
K=4	<b>A=</b> 0.0	0.0	0.0	0.8	2.5	4.0	6.2	10.6	15.0	19.7
K=5	<b>A=</b> 0.0	0.0	0.0	0.8	2.0	3.4	4.8	9.8	14.1	18.4
K=6	<b>A=</b> 0.0	0.0	0.0	0.8	1.5	2.8	4.2	8.7	13.2	17.8
K=7	<b>A=</b> 0.0	0.0	0.0	0.8	1.4	2.3	3.0	7.8	12.0	16.7
K=8	<b>A=</b> 0.0	0.0	0.0	0.2	0.9	1.9	2.7	7.0	11.2	15.7
K=9	<b>A=</b> 0.0	0.0	0.0	0.2	0.7	1.5	2.1	5.9	10.4	15.0

**The above values are calculated on the assumption that the doors have square edges. They are reduced if the doors have radiussed edges.**

**“C” value**

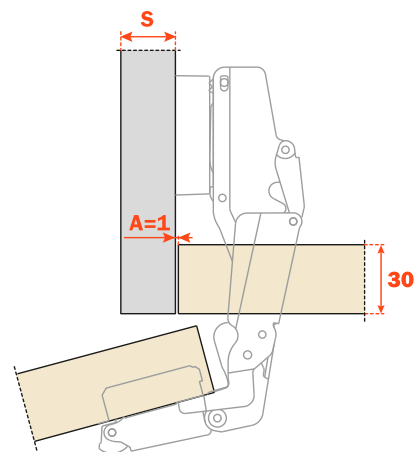
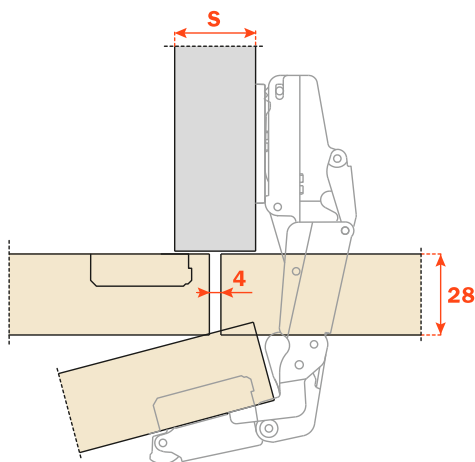



**Packing**

Boxes 100 pcs.  
Pallets 2.400 pcs.

**CA** sprung hinge

Use these formulas to determine the type of hinge arm, the drilling distance "K" and the height of the mounting plate "H" which is necessary to solve each application problem.

To limit the opening of the hinge, see page 362 chapter "Accessories".

Use the tables "Drillings and fixings" at page 83 to complete the code number of the desired hinge.

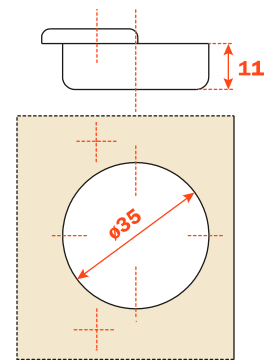

Arm 0

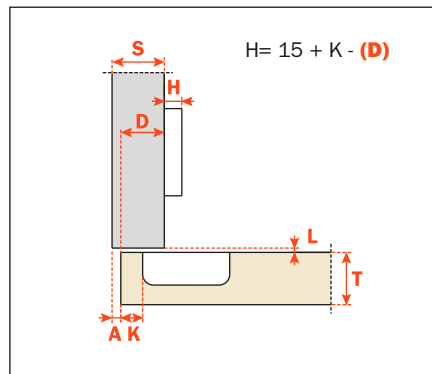

**CA - C2\_DA99**

Arm 5

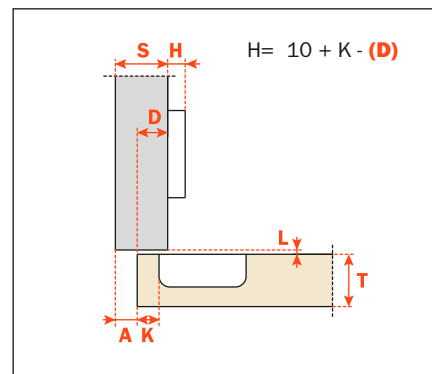

**CA - C2\_DD99**

Arm 9

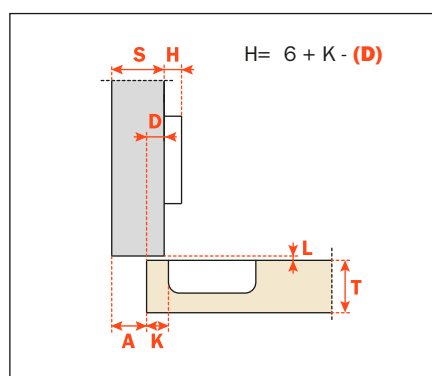

**CA - C2\_DG99**

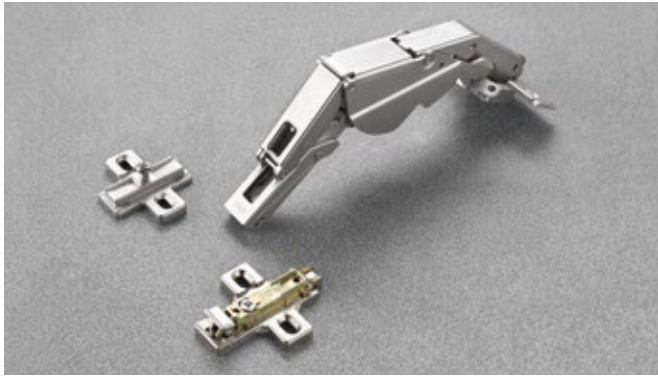

**Technical information**

**For thicker doors max. 35 mm.**  
**Hinge with greater opening angle and reduced operating profile.**  
 11 mm deep die-cast cup.  
 155° opening.  
 Possible drilling distance on the door (K): from 3 to 9 mm.  
 Compatible with all traditional Series 200 mounting plates and with all Domi snap-on mounting plates.

**Space needed to open the door**

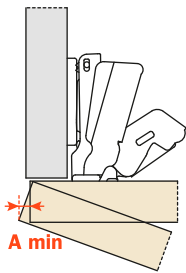

T=	27	28	29	30	31	32	33	34	35	36
K=3	<b>A=</b> 0.0	0.0	0.2	0.6	0.8	1.0	1.4	1.9	2.3	3.0
K=4	<b>A=</b> 0.0	0.0	0.2	0.6	0.8	1.0	1.4	1.9	2.3	3.0
K=5	<b>A=</b> 0.0	0.0	0.2	0.6	0.8	1.1	1.5	1.9	2.5	3.2
K=6	<b>A=</b> 0.0	0.0	0.2	0.6	0.8	1.2	1.6	1.9	2.5	3.8
K=7	<b>A=</b> 0.0	0.0	0.2	0.6	0.8	1.3	1.7	2.1	2.7	3.9
K=8	<b>A=</b> 0.0	0.0	0.2	0.6	0.8	1.4	1.7	2.1	2.7	4.0
K=9	<b>A=</b> 0.0	0.0	0.2	0.6	0.8	1.4	1.7	2.1	3.0	4.0

**The above values are calculated on the assumption that the doors have square edges. They are reduced if the doors have radiussed edges.**

**“C” value**

For spaces with removable components. The door combined with a mounting plate H=0 opens at 90° with lateral door protrusion of 3.5 mm.

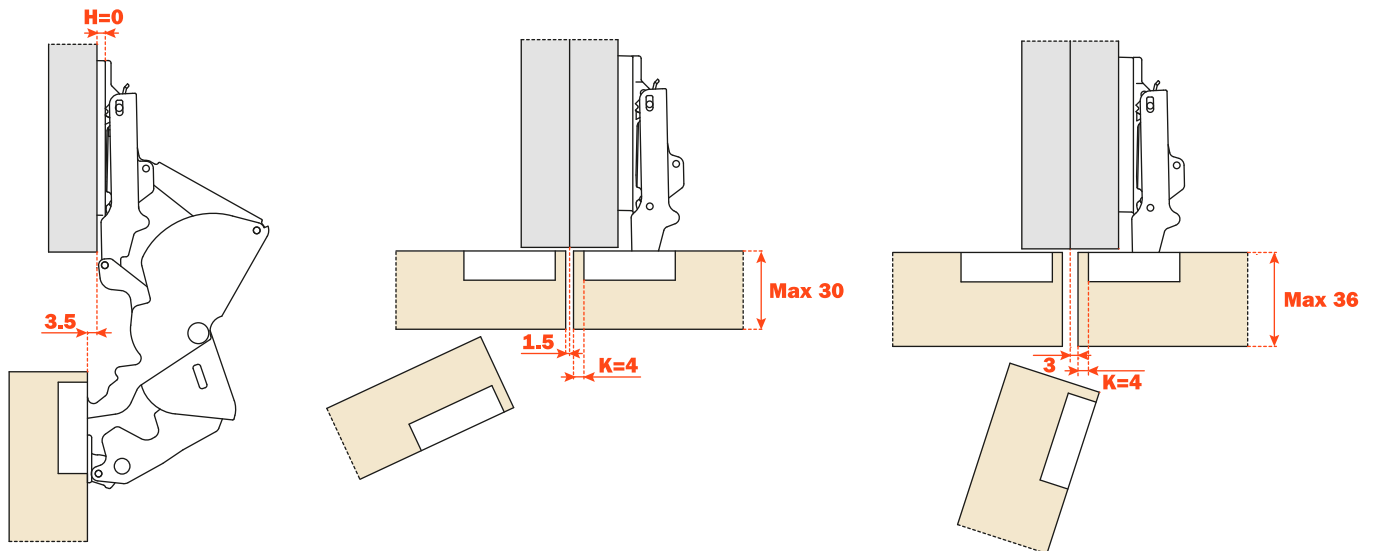

With stop device 110°

**Packing**

Boxes 100 pcs.  
Pallets 2.400 pcs.

**CA** sprung hinge

Use these formulas to determine the type of hinge arm, the drilling distance "K" and the height of the mounting plate "H" which is necessary to solve each application problem.

To limit the opening of the hinge, see page 362 chapter "Accessories".

Use the tables "Drillings and fixings" at page 83 to complete the code number of the desired hinge.

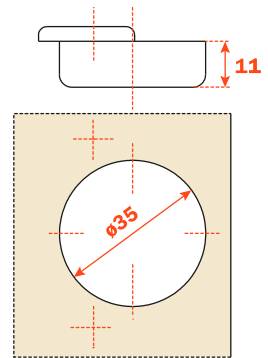

Arm **0**

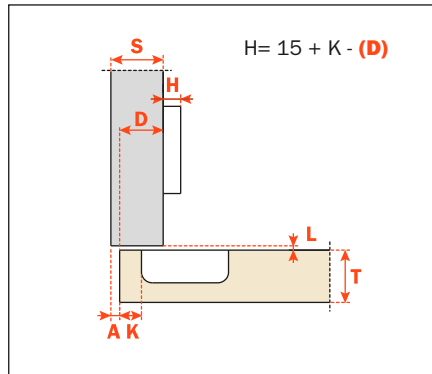
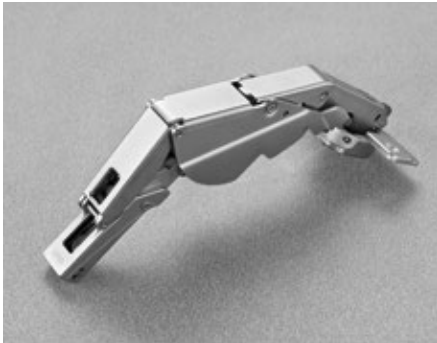

**CA - C2\_HA99**



**Technical information**

**Hinge with greater opening angle and reduced operating profile.**  
 11 mm deep die-cast cup.  
 165° opening.  
 Possible drilling distance on the door (K): from 3 to 8 mm.  
 Compatible with all traditional Series 200 mounting plates and with all Domi snap-on mounting plates.

**Space needed to open the door**

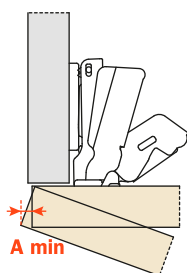

	T=	16	18	20	22	24	26	28
K=3	<b>A=</b>	0.0	0.0	0.0	0.7	2.7	4.6	7.9
K=4	<b>A=</b>	0.0	0.0	0.0	0.1	1.8	3.8	6.9
K=5	<b>A=</b>	0.0	0.0	0.0	0.1	1.2	3.0	5.9
K=6	<b>A=</b>	0.0	0.0	0.0	0.1	0.9	2.5	4.9
K=7	<b>A=</b>	0.0	0.0	0.0	0.1	0.7	2.0	3.9
K=8	<b>A=</b>	0.0	0.0	0.0	0.1	0.6	1.7	3.2

**The above values are calculated on the assumption that the doors have square edges. They are reduced if the doors have radiussed edges.**

**“C” value**

For spaces with removable components. Opening with lateral door protrusion equal to 5.5 mm with a hinge with straight arm, H=0 mounting plate and K=3 mm.

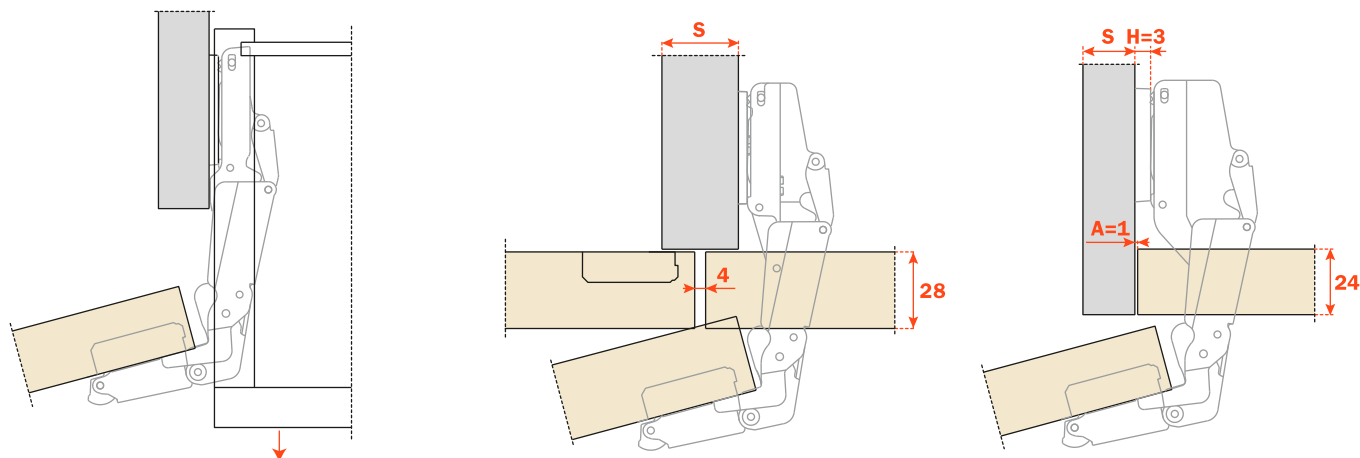

**Packing**

Boxes 100 pcs.  
Pallets 2.400 pcs.

**CA** sprung hinge  
**CL** unsprung hinge

Use these formulas to determine the type of hinge arm, the drilling distance "K" and the height of the mounting plate "H" which is necessary to solve each application problem.

To limit the opening of the hinge, see page 362 chapter "Accessories".

Use the tables "Drillings and fixings" at page 83 to complete the code number of the desired hinge.

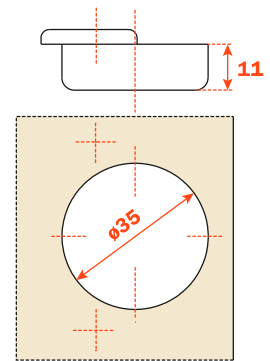
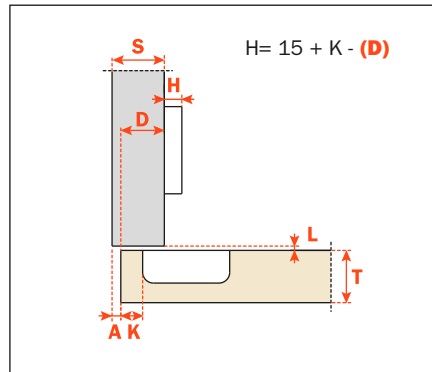
**Arm 0**

**CA - C2\_FA99**  
**CL - C2\_EA99**

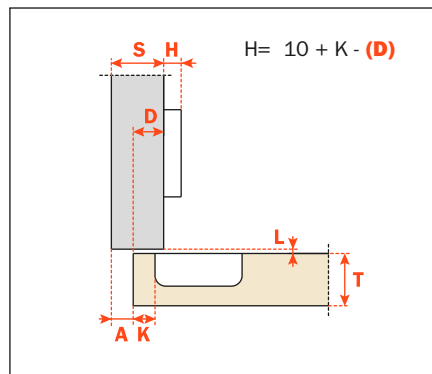
**Arm 5**

**CA - C2\_FD99**  
**CL - C2\_ED99**

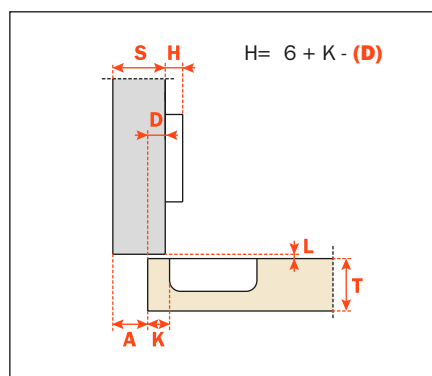
**Arm 9**

**CA - C2\_FG99**  
**CL - C2\_EG99**

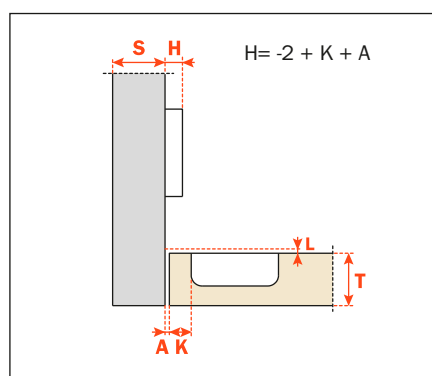
**Arm 17**

**CA - C2\_FP99**  
**CL - C2\_EP99**



### Technical information

#### Hinges for glass doors.

Hole diameter 26 mm.

94° opening.

For use with glass from 4 mm to 6 mm thickness.

Possible drilling distance on the door (K): from 5.5 to 6.5 mm.

Compatible with all traditional Series 200 mounting plates and with all Domi snap-on mounting plates.

### P2CTA

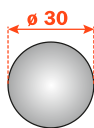

### Fancy covers

See page 360 chapter "Accessories" for the available finishes.

### P2CBA

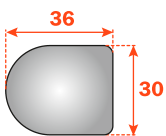



**Packing**

Boxes 150 pcs.  
Pallets 3.600 pcs.

Use these formulas to determine the type of hinge arm, the drilling distance "K" and the height of the mounting plate "H" which is necessary to solve each application problem.

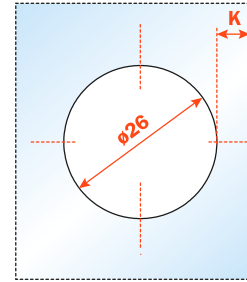
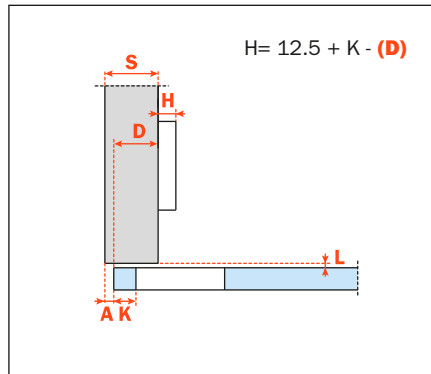
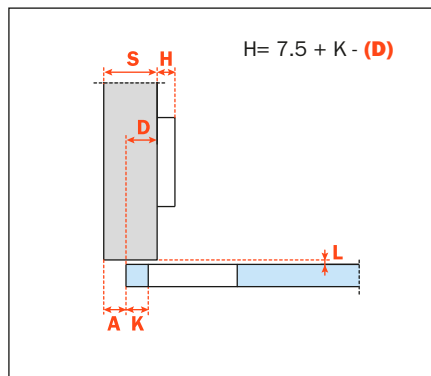
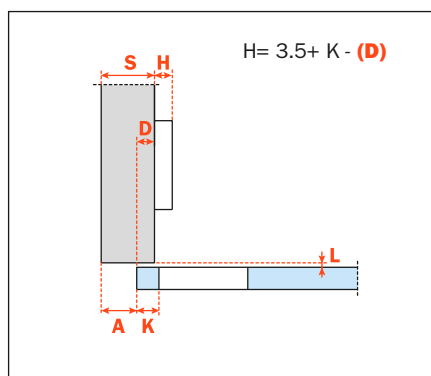
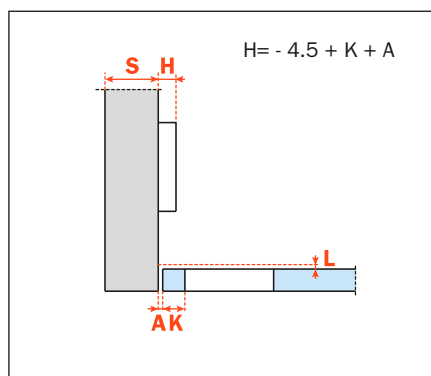
**CA sprung hinge****Arm 0****CA - C2C7A39****Arm 5****CA - C2C7D39****Arm 9****CA - C2C7G39****Arm 17****CA - C2C7P39**



## Packing

Boxes 150 pcs.  
Pallets 3.600 pcs.

## CA sprung hinge

The solution of assembly problems where doors are mounted at a positive or negative angle requires the verification of drilling distances by a practical trial. Please do not hesitate to consult our technical support department for assistance.

## Technical information

### Hinges for glass doors with positive angled assembly.

Hole diameter 26 mm.

94° opening.

For use with glass from 4 mm to 6 mm thickness.

Possible drilling distance on the door (K): from 5.5 to 6.5 mm.

Compatible with all Series 200 traditional mounting plates and with all Domi snap-on mounting plates.

Applications with doors set at any angle between - 7.5° to + 70° are possible by combining the appropriate hinge and mounting plate.

### Arm 30°

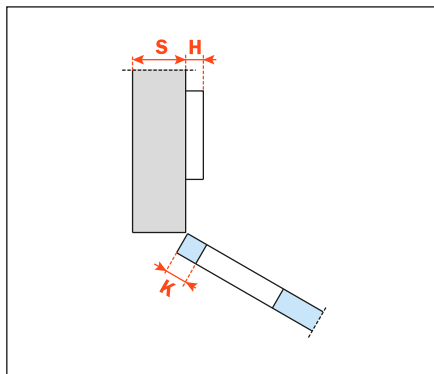

**CA - C2C7E39**

### Arm 45°

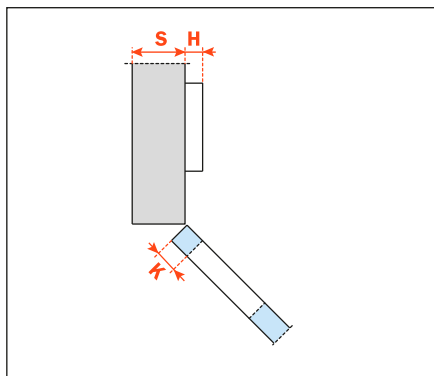

**CA - C2C7M39**

### Crampon

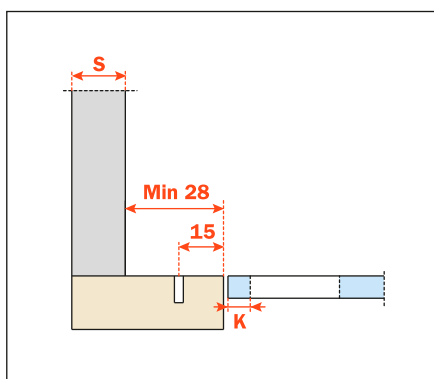

**Crampon hinges.** To be used only with Series 200 mounting plates for traditional assembly and drilling 28x32 mm.

**CA - C2C7N39**

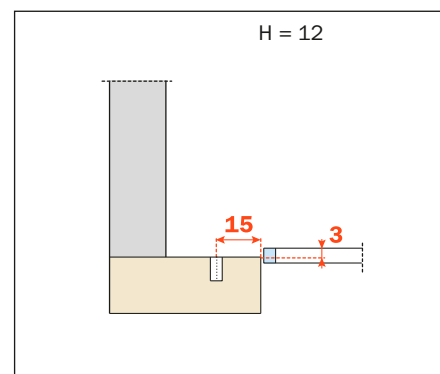
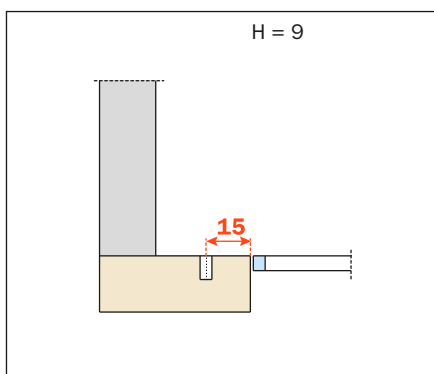
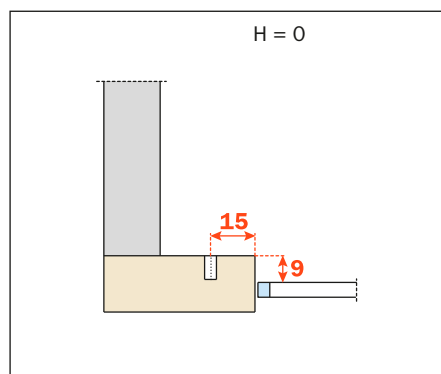



**Technical information**

**Hinges for fridge doors.**

11 mm deep metal cup.

94° opening.

Possible drilling distance on the door (K): from 3 to 9 mm.

Compatible with all traditional Series 200 mounting plates.

**NOT COMPATIBLE** with Domi snap-on mounting plates.

**Packing**

Boxes 150 pcs.

Pallets 3.600 pcs.

Use the tables "Drillings and fixings" at page 83 to complete the code number of the desired hinge.

**CA** sprung hinge

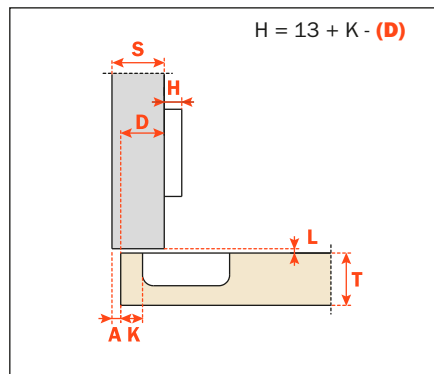
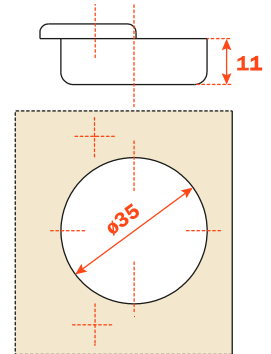

**CA - C2\_BF99**

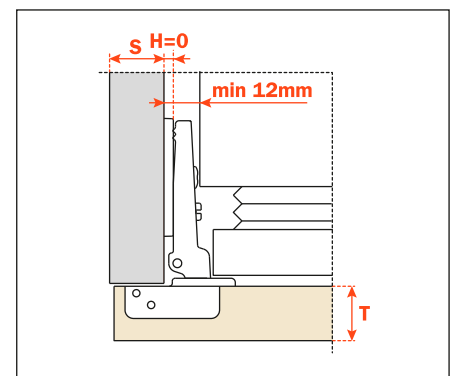



**Technical information**

**Hinges for wooden doors with positive angled assembly.**

11 mm deep metal cup.

94° opening.

Possible drilling distance on the door (K): from 3 to 9 mm.

Compatible with all traditional Series 200 mounting plates and with all Domi snap-on mounting plates.

**Packing**

Boxes 150 pcs.

Pallets 3.600 pcs.

**CA** sprung hinge

The solution of assembly problems where doors are mounted at a positive or negative angle requires the verification of drilling distances by a practical trial. Please do not hesitate to consult our technical support department for assistance.

Use the tables “Drillings and fixings” at page 83 to complete the code number of the desired hinge.

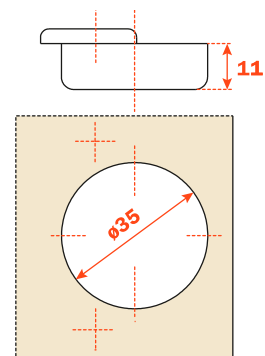

Arm **15°**

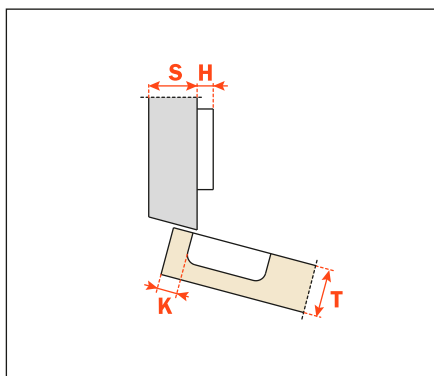

**CA - C2\_BZ99**

Arm **24°**

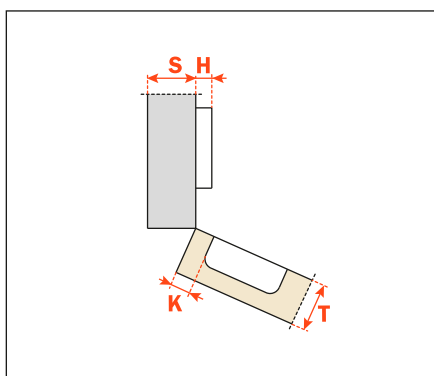

**CA - C2\_BU99**

Arm **30°**

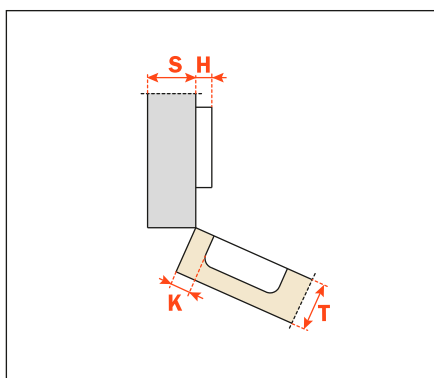

**CA - C2\_BE99**

Arm 30°

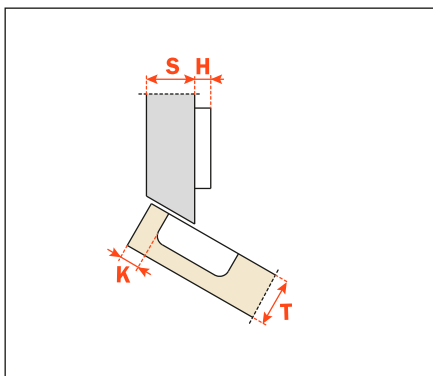

**CA - C2\_BT99**

Arm 37°

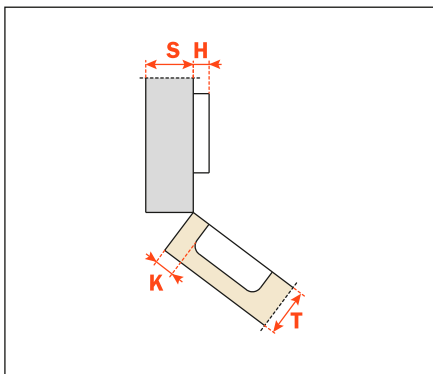

**CA - C2\_BK99**

Arm 45°

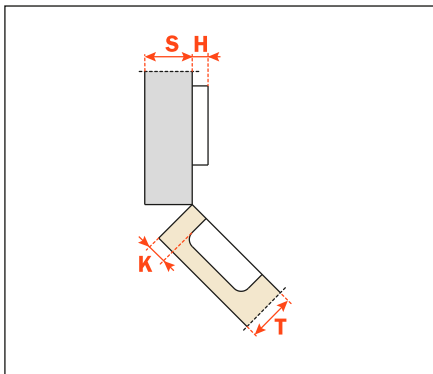

**CA - C2\_BM99**

Arm 45°

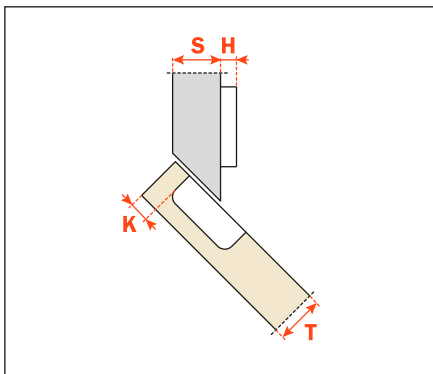

**CA - C2\_BV99**

Arm 45°

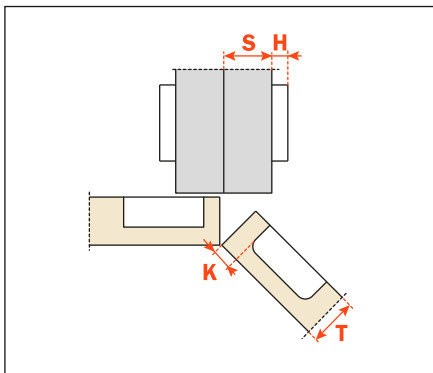

**CA - C2\_BM99AC**





**Technical information**

**Hinges for wooden doors with negative angled assembly.**

11 mm deep metal cup.  
 120° opening.  
 Possible drilling distance on the door (K): from 3 to 6 mm.  
 Compatible with all traditional Series 200 mounting plates and with all Domi snap-on mounting plates.

**Packing**

Boxes 150 pcs.  
 Pallets 3.600 pcs.

**CA** sprung hinge

The solution of assembly problems where doors are mounted at a negative angle requires the verification of drilling distances by a practical trial. Please do not hesitate to consult our technical support department for assistance.

Use the tables "Drillings and fixings" at page 83 to complete the code number of the desired hinge.

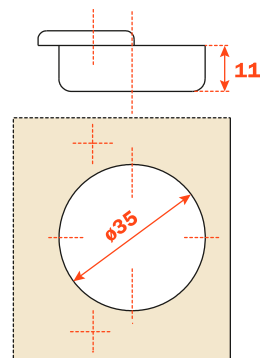

Arm **-30°**

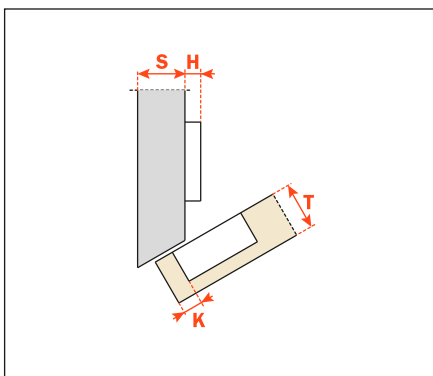

**CA - C2\_7W99**

Arm **-45°**

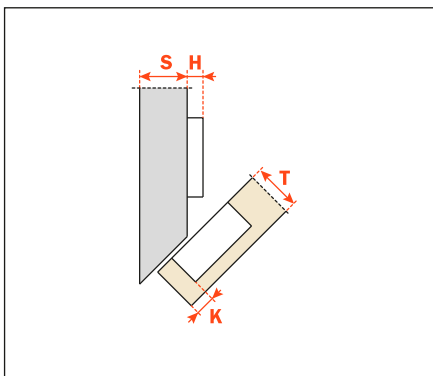

**CA - C2\_7H99**



## Technical information

### Crampon hinges.

**For cabinet sides with 37x32 mm standard drilling.**

11 mm deep metal cup.

94° opening.

Possible drilling distance on the door (K): from 3 to 9 mm.

Compatible with all traditional Series 200 mounting plates and with all Domi snap-on mounting plates.

### Packing

Boxes 150 pcs.

Pallets 3.600 pcs.

**CA** sprung hinge

### E min:

61 mm for Series 200 mounting plates.

70 mm for Domi snap-on mounting plates.

74 mm for Domi snap-on mounting plates with back cam.

Use the tables "Drillings and fixings" at page 83 to complete the code number of the desired hinge.

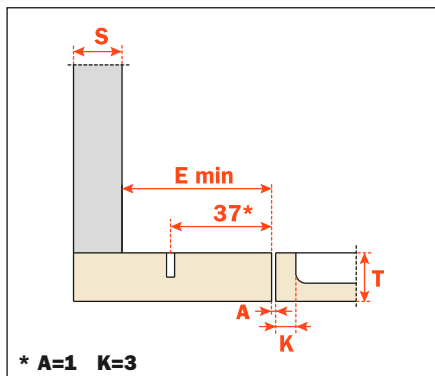
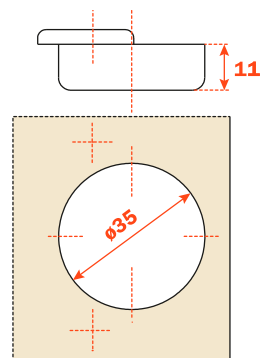

**CA - C2\_BN99AC**

Heights of mounting plates for every assembly.

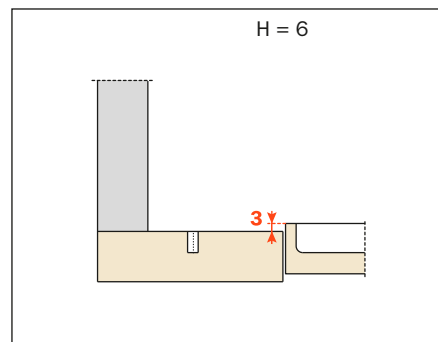
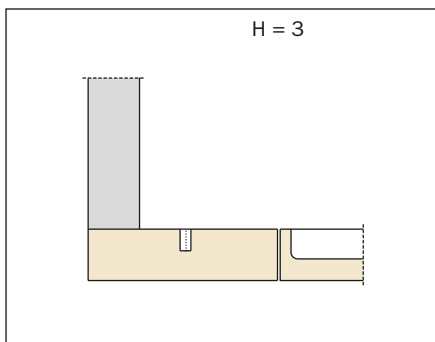
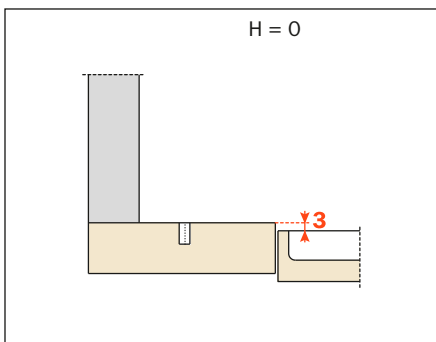



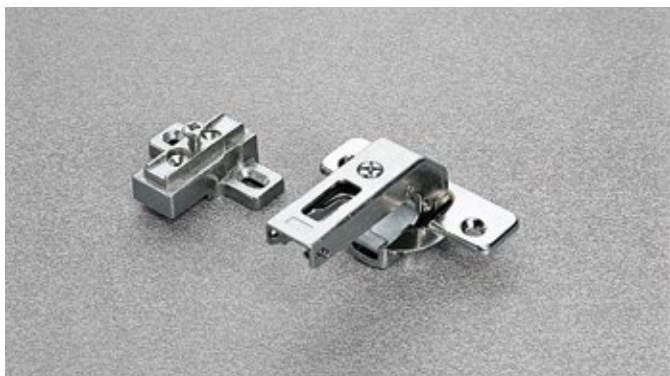

**Technical information**

**Crampon hinges.**

**For smaller spaces with 15x32 mm drilling.**

11 mm deep metal cup.

94° opening.

Possible drilling distance on the door (K): from 3 to 9 mm.  
Compatible with all traditional Series 200 mounting plates, 28x32 mm drilling.

**NOT COMPATIBLE** with Domi snap-on mounting plates.

**Packing**

Boxes 150 pcs.

Pallets 3.600 pcs.

Use the tables "Drillings and fixings" at page 83 to complete the code number of the desired hinge.

**CA** sprung hinge

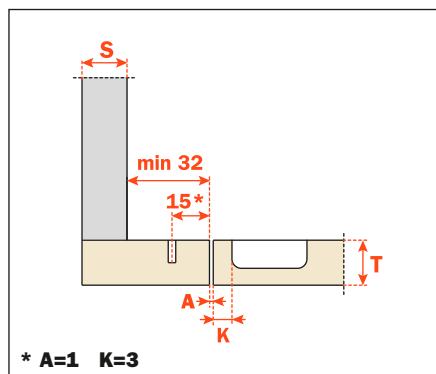
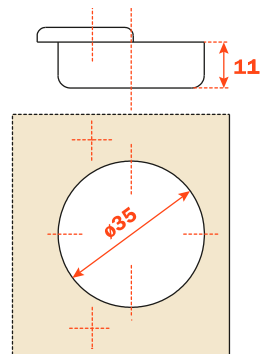

**CA - C2\_BN99**

Heights of mounting plates for every assembly.

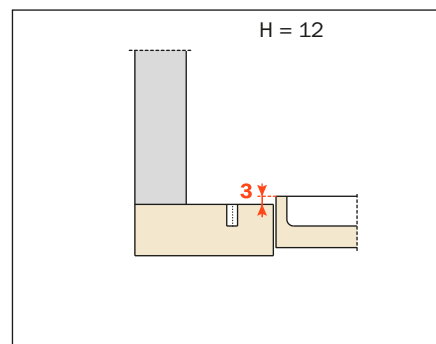
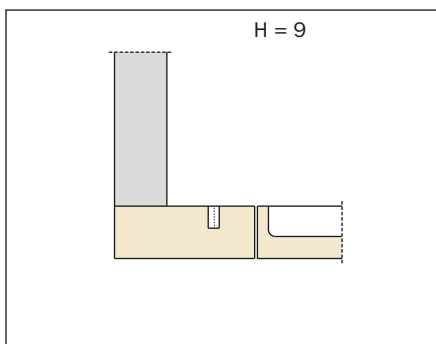
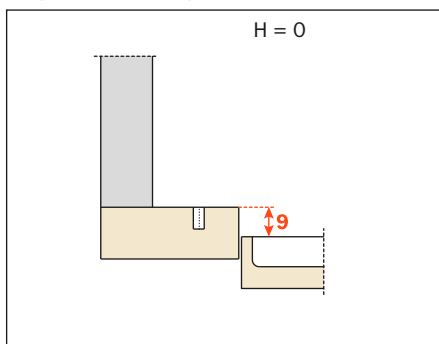



## Technical information

### Long crampon hinges.

11 mm deep metal cup.

110° opening.

Possible drilling distance on the door (K): from 3 to 6 mm.

Compatible with all traditional Series 200 mounting plates and with all Domi snap-on mounting plates.

### Packing

Boxes 150 pcs.

Pallets 3.600 pcs.

### CA sprung hinge

### E min:

61 mm for Series 200 mounting plates.

70 mm for Domi snap-on mounting plates.

74 mm for Domi snap-on mounting plates with back cam.

Use the tables "Drillings and fixings" at page 83 to complete the code number of the desired hinge.

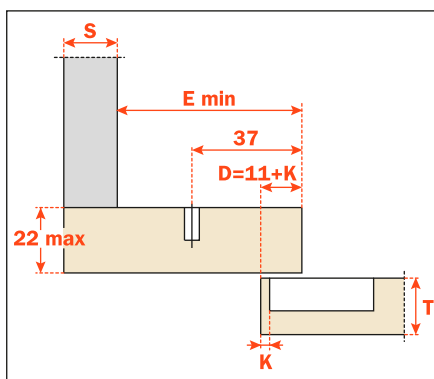
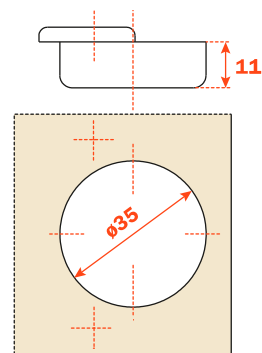

## CA - C2\_6N99AM

Heights of mounting plates for every assembly.

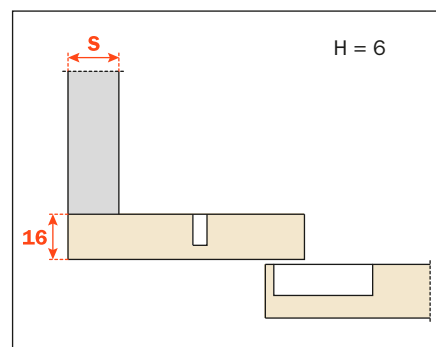
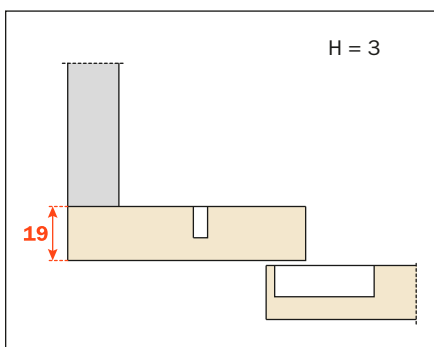
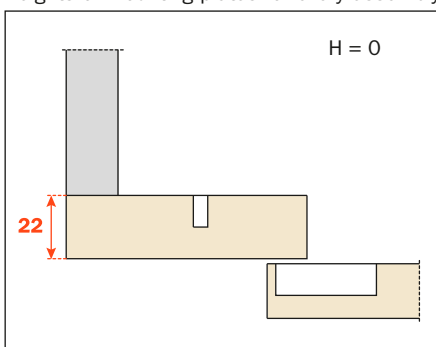



## Technical information

### Hinges for corner cabinets.

11 mm deep die-cast cup.  
 35 mm cup diameter.  
 Opening angle of the first door 70°.  
 Possible drilling distance on the door (K) : from 3 to 6 mm.

Maximum thickness of the door with square edges: 23 mm.  
 For thicker doors or doors with mouldings or with large radiused edges, please refer to our technical assistance.  
 Compatible with all traditional Series 200 mounting plates and with all Domi snap-on mounting plates.

### Packing

Boxes 150 pcs.  
 Pallets 3.600 pcs.

Use the tables "Drillings and fixings" at page 83 to complete the code number of the desired hinge.

CA sprung hinge

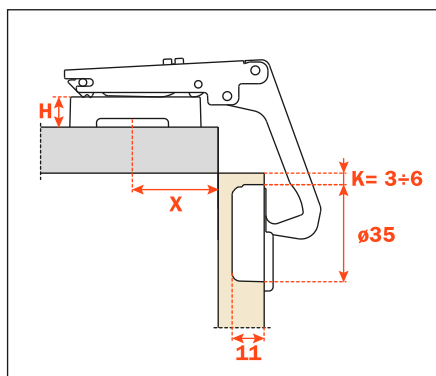
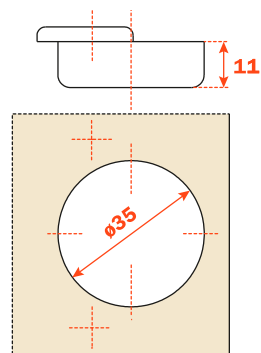

CA - C2\_YA99

Use these formulas to determine the height of mounting plate and drilling distance

Drilling distance:  
 cruciform mounting plates =  $47 - T$

Drilling distance:  
 longitudinal mounting plates =  $(31 - T) + 32$

$H^* = 26 - T - K$   
 The mounting plate heights that are not standard are obtained with the mounting plate of lower height + sideways adjustment

T= Thickness of the door with square edges

Examples with doors with square edges

T	K	X	X	H
20	5	$47 - 20 = 27$ mm	$31 - 20 = 11 + 32$ mm	$26 - 20 - 5 = 1$ mm
16	6	$47 - 16 = 31$ mm	$31 - 16 = 15 + 32$ mm	$26 - 16 - 6 = 4$ mm
19	3	$47 - 19 = 28$ mm	$31 - 19 = 12 + 32$ mm	$26 - 19 - 3 = 4$ mm
18	4	$47 - 18 = 29$ mm	$31 - 18 = 13 + 32$ mm	$26 - 18 - 4 = 5$ (H = 4 + 1 mm adjustment)

## C2AYA99 hinge movement and maximum opening width

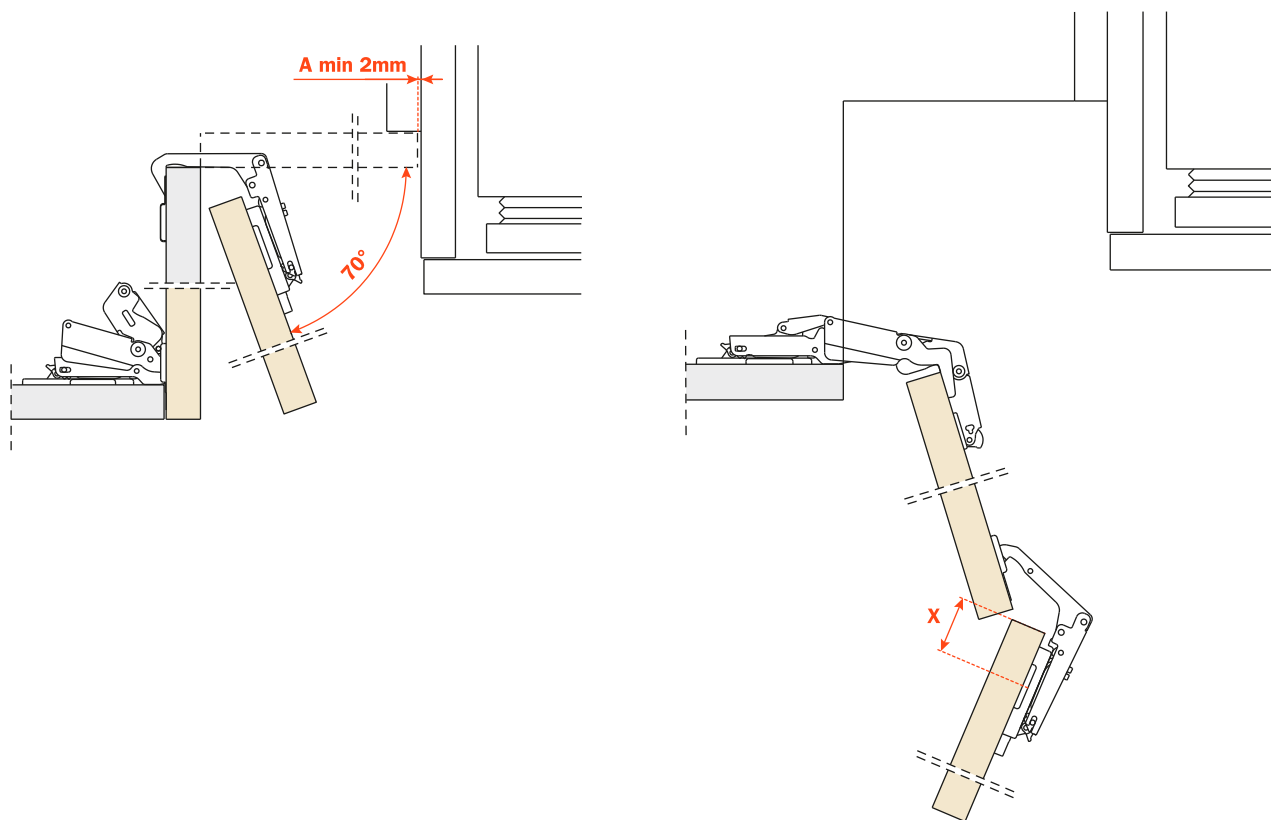

## Space required to accommodate the hinge

### With Series 200 mounting plates

The maximum space required to accommodate the hinge is 52 mm with 16 mm thick doors. With thicker doors the amount of space required is reduced.

### With Domi snap-on mounting plates

The maximum space required to accommodate the hinge with 16 mm thick doors is 64 mm with Domi mounting plates and 68 mm with mounting plates with back cam. With thicker doors the amount of space required is reduced.

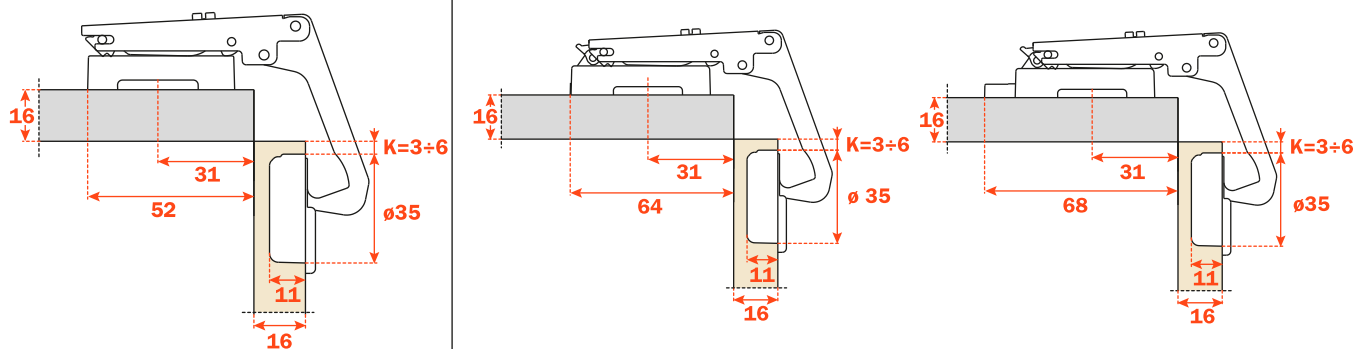

# Series 200 - Complementary hinges - Special angled assemblies

C2A7H99  
B2V3B09/15

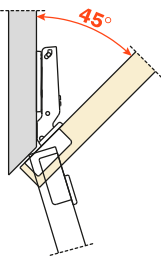

C2A7W99  
B2V3B09/15

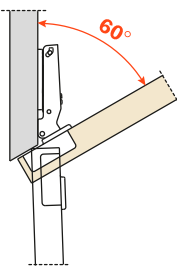

C2A7W99  
B2V3BW9R/15

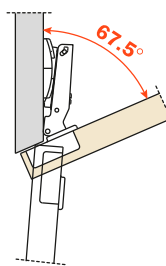

CFA7A99  
B2V3BW9/15

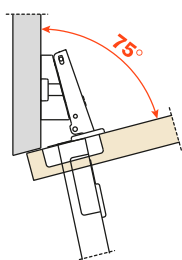

C2A7A99  
B2V3BW9R/15

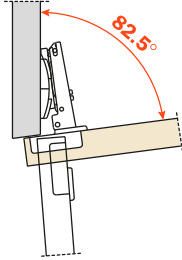

C2A7A99  
B2V3BW9R/15

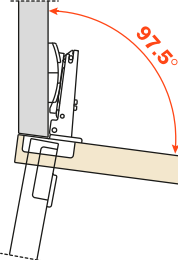

C2A7A99  
B2V3BW9S/15

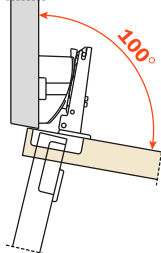

C2A7Z99  
B2V3B09/15

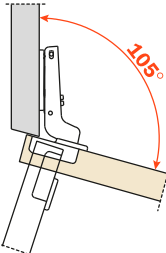

C2A7U99  
B2V3B09/15

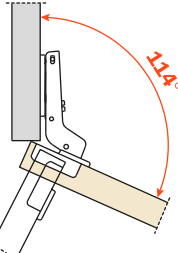

C2A7E99  
B2V3B09/15

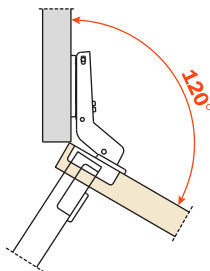

C2A7K99  
B2V3B09/15

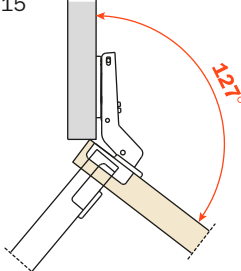

C2A7M99  
B2V3B09/15

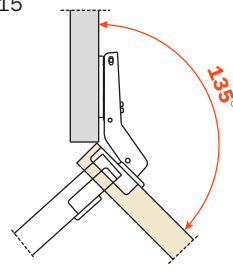

C2A7M99  
B2V3BW9R/15

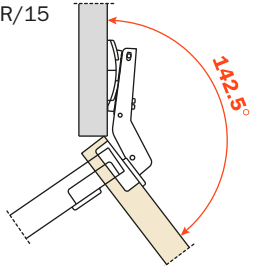

C2A7M99  
B2V3BW9/15

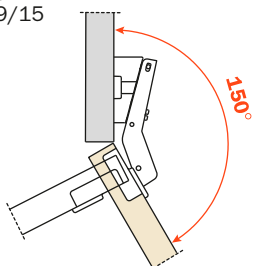

C2A7M99  
B2V3BW9S/15

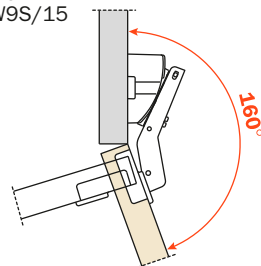

## Series F



Series F



**Bright nickel plated steel cup and die-cast arm.  
Dimensions of the Ø 40 mm cup.**

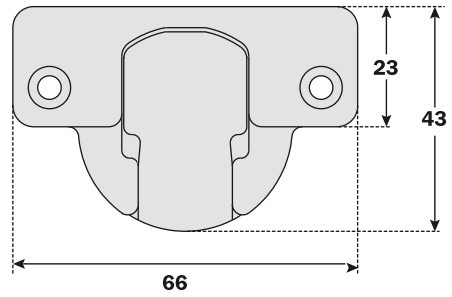

Constant "L" value of 0.7 mm (it does not change during side adjustment).

Approx. number of hinges required according to the door dimension and weight.

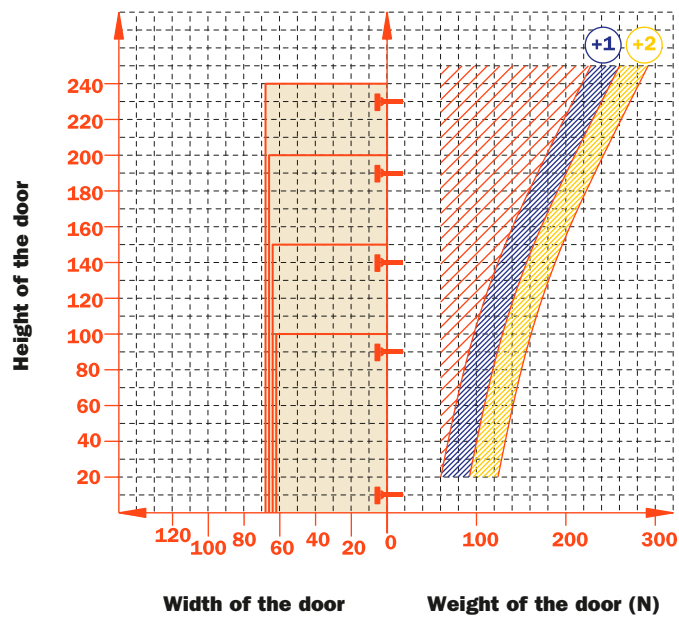

**Adjustments**

Compensated side adjustment from -0.5 mm to +5.5 mm.  
Height adjustment ±2 mm.  
Depth adjustment with Series 200 mounting plates +2.8 mm.  
Depth adjustment with Domi mounting plates from -0.5 mm to +2.8 mm.

**Mounting plates**

Symmetrical and asymmetrical bright nickel plated steel or die-cast Series 200 mounting plates.  
Snap-on assembly on Domi mounting plates.  
Positioning with pre-determined stop on traditional Series 200 mounting plates.

N.B. : Use POZIDRIVE No. 2 screwdrivers for all screws.

<p>Wood screw</p>	<p><b>A</b></p>

<p>Dowel</p>	<p><b>B</b></p>

**Use this table to identify the available drillings and fixings.  
 Fill the third position of the hinge code number with the letter or the number  
 corresponding to your choice. I.e.: CF\_7A99.**



Fill this position with the chosen letter or number.



## Technical information

### For profile and thicker doors (max. 40 mm).

13 mm deep steel cup.

40 mm cup diameter.

94° opening.

Possible drilling distance on the door (K): from 3 to 15 mm.

Compatible with all traditional Series 200 mounting plates and with all Domi snap-on mounting plates.

## Space needed to open the door

	T=	20	21	22	23	24	25	26	27	28	29	30	31	32	33	34	35	36	37	38	39	40	L=
K=3	A=	0.4	0.5	0.7	0.8	1.0	1.2	1.4	1.6	1.9	2.2	2.5	2.8	3.1	3.5	4.1	5.0	6.0	6.9	7.8	8.8	9.7	0.0
K=4	A=	0.4	0.5	0.7	0.8	1.0	1.2	1.4	1.6	1.9	2.1	2.4	2.7	3.0	3.4	3.8	4.4	5.3	6.3	7.2	8.1	9.0	0.0
K=5	A=	0.4	0.5	0.6	0.8	1.0	1.2	1.4	1.6	1.8	2.1	2.4	2.7	3.0	3.3	3.7	4.1	4.8	5.7	6.6	7.5	8.4	0.0
K=6	A=	0.4	0.5	0.6	0.8	0.9	1.1	1.3	1.6	1.8	2.1	2.3	2.6	2.9	3.3	3.6	4.0	4.4	5.2	6.0	6.9	7.8	0.0
K=7	A=	0.4	0.5	0.6	0.8	0.9	1.1	1.3	1.5	1.8	2.0	2.3	2.6	2.9	3.2	3.6	3.9	4.3	4.8	5.5	6.4	7.3	0.0
K=8	A=	0.4	0.5	0.6	0.8	0.9	1.1	1.3	1.5	1.7	2.0	2.2	2.5	2.8	3.1	3.5	3.8	4.2	4.7	5.1	5.9	6.8	0.0
K=9	A=	0.4	0.5	0.6	0.7	0.9	1.1	1.3	1.5	1.7	2.0	2.2	2.5	2.8	3.1	3.4	3.8	4.2	4.6	5.0	5.5	6.3	0.0
K=10	A=	0.3	0.5	0.6	0.7	0.9	1.1	1.3	1.5	1.7	1.9	2.2	2.4	2.7	3.0	3.4	3.7	4.1	4.5	4.9	5.4	6.0	0.0
K=11	A=	0.3	0.4	0.6	0.7	0.9	1.0	1.2	1.4	1.7	1.9	2.1	2.4	2.7	3.0	3.3	3.6	4.0	4.4	4.8	5.2	5.7	0.0
K=12	A=	0.3	0.4	0.6	0.7	0.9	1.0	1.2	1.4	1.6	1.9	2.1	2.4	2.6	2.9	3.3	3.6	3.9	4.3	4.7	5.1	5.6	0.4
K=13	A=	0.3	0.4	0.5	0.7	0.9	1.0	1.2	1.4	1.6	1.8	2.1	2.3	2.6	2.9	3.2	3.5	3.8	4.2	4.5	4.9	5.4	1.2
K=14	A=	0.3	0.4	0.5	0.7	0.8	1.0	1.2	1.4	1.6	1.8	2.0	2.3	2.6	2.8	3.2	3.5	3.8	4.2	4.5	4.9	5.4	2.2
K=15	A=	0.3	0.4	0.5	0.7	0.8	1.0	1.2	1.4	1.6	1.8	2.0	2.3	2.6	2.8	3.2	3.5	3.8	4.2	4.5	4.9	5.4	3.2

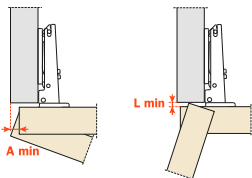

The above values are calculated on the assumption that the doors have square edges. They are reduced if the doors have radiused edges.

## Projection of the door

Projection of the door from the cabinet side at the max. opening. The figures are based on a straight arm hinge, H=0 mm thickness of mounting plate and K value = 3 mm.

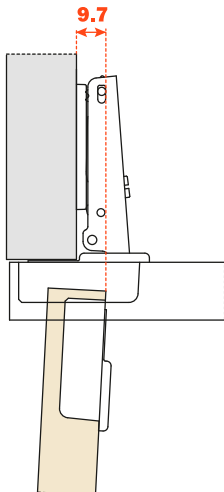

## "C" value

With this formula you can obtain the max. thickness of the moulded door that can be opened without touching adjacent carcase sides, doors or walls, whilst bearing in mind the above L-K-T values.

$$C = 28.5 + K + A$$

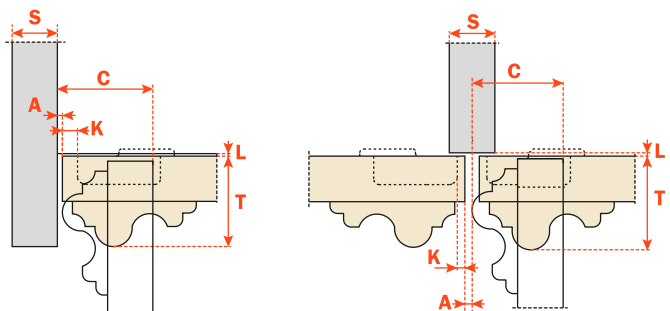

**Packing**

Boxes 300 pcs.  
Pallets 7.200 pcs.

**CA** sprung hinge  
**CL** unsprung hinge

Use these formulas to determine the type of hinge arm, the drilling distance "K" and the height of the mounting plate "H" which is necessary to solve each application problem.

Use the tables "Drillings and fixings" at page 113 to complete the code number of the desired hinge.

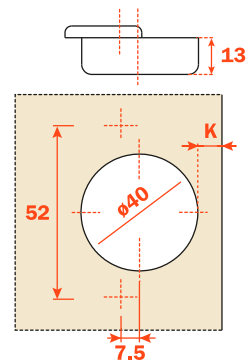
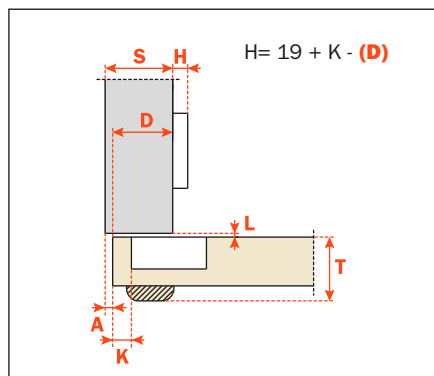
**Arm 0**

**CA - CF\_7A99**  
**CL - CF\_5A99**

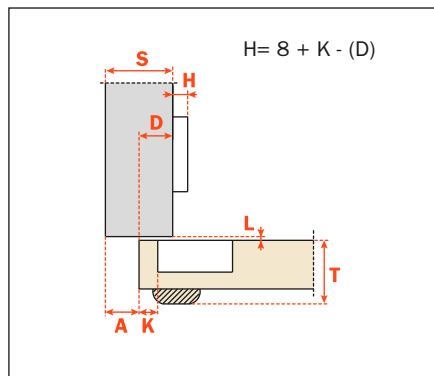
**Arm 11**

**CA - CF\_7G99**  
**CL - CF\_5G99**

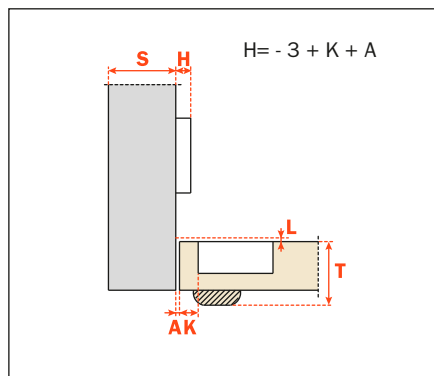
**Arm 22**

**CA - CF\_7P99**  
**CL - CF\_5P99**

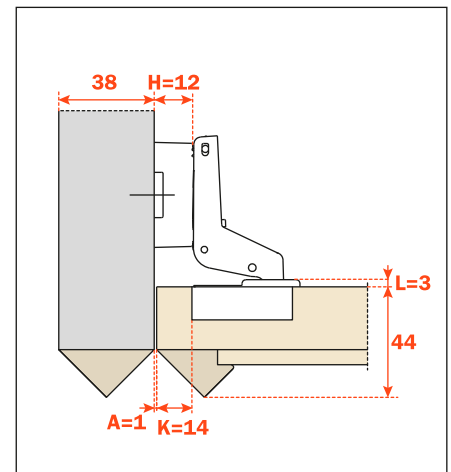
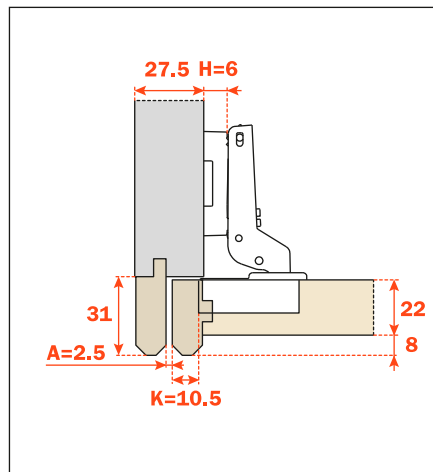
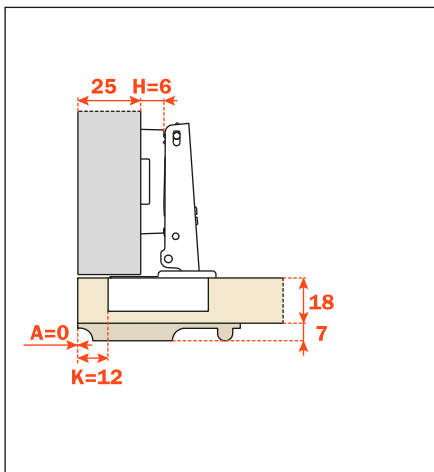
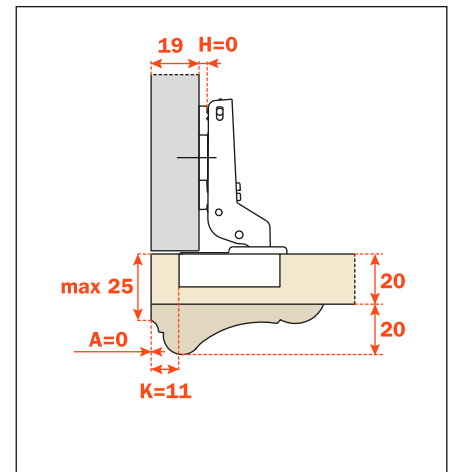
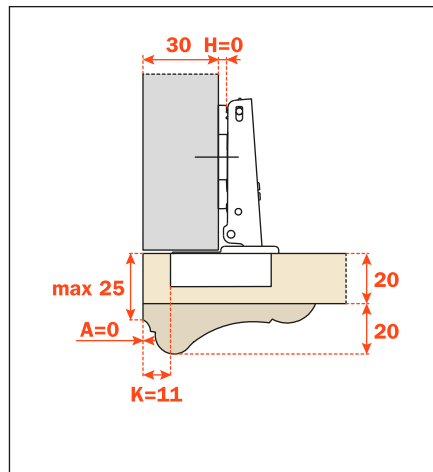
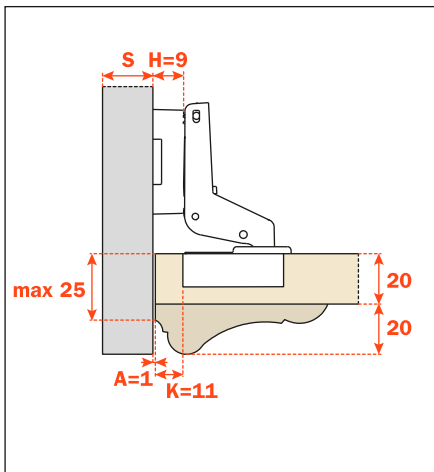
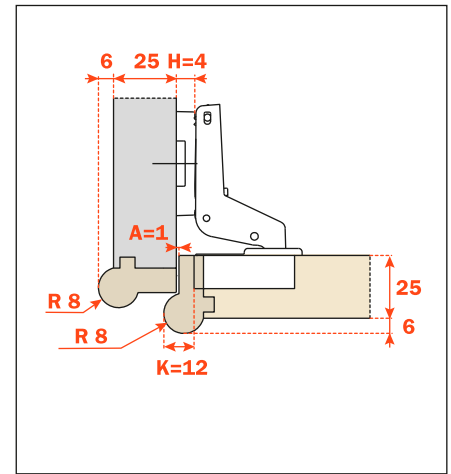
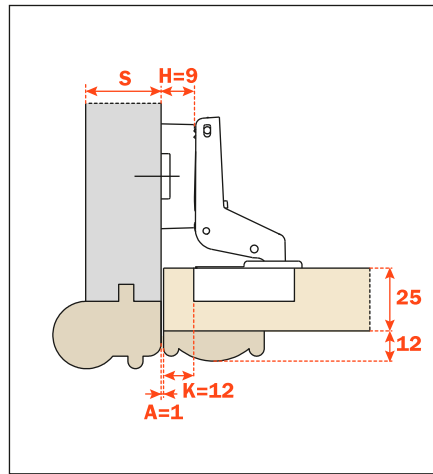
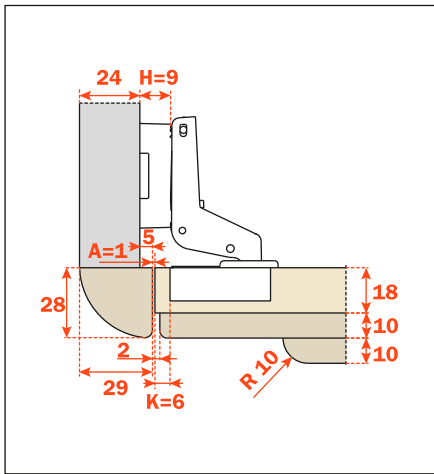
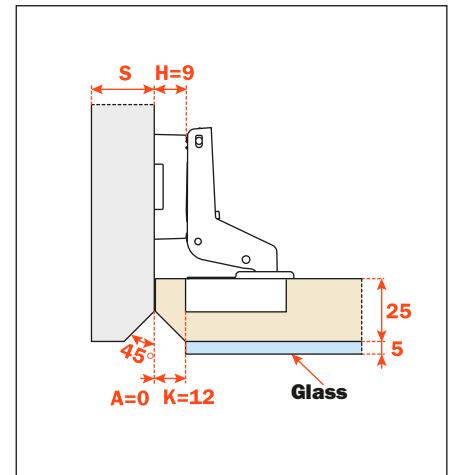
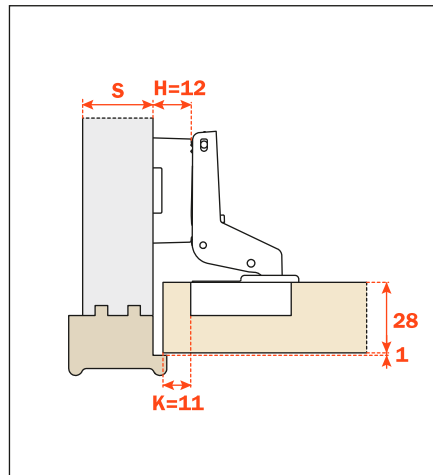
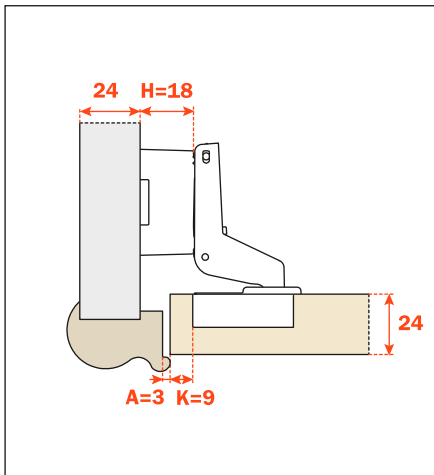

## Series 300





Hinges with a small operating profile.  
Bright nickel plated steel cup and arm.  
Dimensions of the  $\varnothing$  35 mm cup.

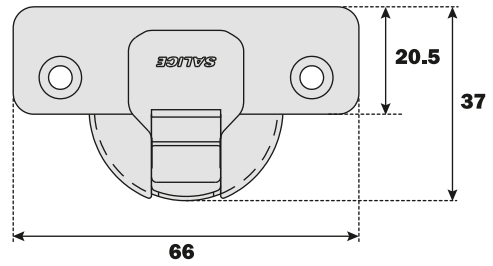

Constant "L" value of 0.7 mm (it does not change during side adjustment).

Approx. number of hinges required according to the door dimension and weight.

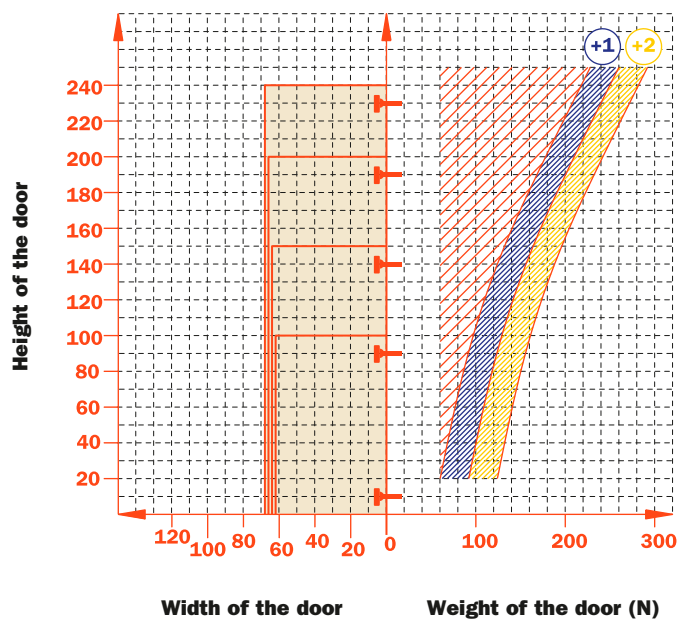

### Adjustments

Compensating side adjustment from -1.5 mm to +3 mm.  
Height adjustment  $\pm 1.5$  mm by cam.  
Depth adjustment with Series 300 mounting plates +2.8 mm.  
Anti-sliding safety stop.

### Mounting plates

Asymmetrical bright nickel plated die-cast Series 300 mounting plates.  
Positioning with pre-determined stop.

N.B. : Use POZIDRIVE No. 2 screwdrivers for all screws.

	<p>48  <math>\varnothing 35</math>            6  <math>94^\circ</math></p>	<p>45  <math>\varnothing 35</math>            9.5  <math>94^\circ</math></p>	<p>52  <math>\varnothing 35</math>            5.5  <math>94^\circ</math></p>
<p>Wood screw</p>	<b>A</b>	<b>P</b>	<b>U</b>
	<p>48  <math>\varnothing 35</math>  <math>\varnothing 10</math>            6  <math>94^\circ</math></p>	<p>45  <math>\varnothing 35</math>  <math>\varnothing 8</math>            9.5  <math>94^\circ</math></p>	<p>52  <math>\varnothing 35</math>  <math>\varnothing 10</math>            5.5  <math>94^\circ</math></p>
<p>Dowel</p>	<b>B</b>	<b>R</b>	<b>W</b>

Use this table to identify the available drillings and fixings.

Fill the third position of the hinge code number with the letter or the number corresponding to your choice. I.e.: C3\_BA99.



Fill this position with the chosen letter or number.



**Technical information**

**Hinges with just 45 mm operating profile.**  
 11 mm deep metal cup.  
 94° opening.  
 Possible drilling distance on the door (K): from 3 to 9 mm.  
 Compatible with all traditional Series 300 mounting plates.

**Space needed to open the door**

	T=	19	20	21	22	23	24	25	26	27	28	29	30	31	32	33	34	35
K=3	<b>A=</b>	0.1	0.2	0.3	0.4	0.5	0.7	0.8	1.0	1.6	2.6	3.5	4.5	5.4	6.4	7.4	8.3	9.3
K=4	<b>A=</b>	0.1	0.2	0.3	0.4	0.5	0.7	0.8	1.0	1.2	1.9	2.8	3.8	4.7	5.7	6.6	7.6	8.6
K=5	<b>A=</b>	0.1	0.2	0.3	0.4	0.5	0.7	0.8	1.0	1.2	1.4	2.2	3.1	4.1	5.0	5.9	6.9	7.8
K=6	<b>A=</b>	0.1	0.2	0.3	0.4	0.5	0.6	0.8	1.0	1.2	1.4	1.7	2.6	3.5	4.4	5.3	6.2	7.2
K=7	<b>A=</b>	0.1	0.2	0.3	0.4	0.5	0.6	0.8	1.0	1.1	1.3	1.6	2.1	3.0	3.8	4.7	5.6	6.5
K=8	<b>A=</b>	0.1	0.2	0.3	0.4	0.5	0.6	0.8	0.9	1.1	1.3	1.6	1.8	2.5	3.3	4.2	5.1	6.0
K=9	<b>A=</b>	0.1	0.2	0.3	0.4	0.5	0.6	0.8	0.9	1.1	1.3	1.5	1.8	2.1	2.9	3.7	4.6	5.4

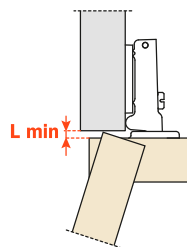
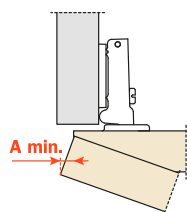

K=	3	4	5	6	7	8	9
<b>L=</b>	0.0	0.0	0.0	0.0	0.0	0.3	1.3

The above values are calculated on the assumption that the doors have square edges. They are reduced if the doors have radiussed edges.

**Projection of the door**

Projection of the door from the cabinet side at the max. opening. The figures are based on a straight arm hinge, H=0 mm thickness of mounting plate and K value = 3 mm.

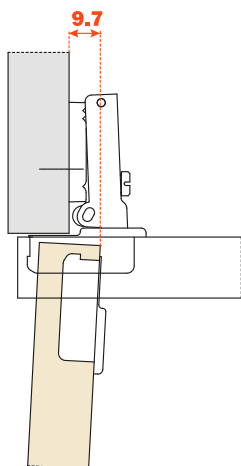

**“C” value**

With this formula you can obtain the max. thickness of the moulded door that can be opened without touching adjacent carcass sides, doors or walls, whilst bearing in mind the above L-K-T values.

$C = 22.5 + K + A$

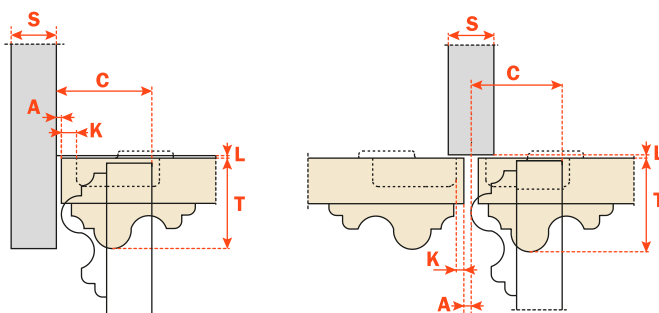

**Packing**

Boxes 300 pcs.  
Pallets 7.200 pcs.

**CA** sprung hinge

Use these formulas to determine the type of hinge arm, the drilling distance "K" and the height of the mounting plate "H" which is necessary to solve each application problem.

Use the tables "Drillings and fixings" at page 119 to complete the code number of the desired hinge.

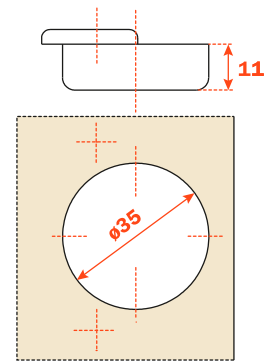

## Arm 0

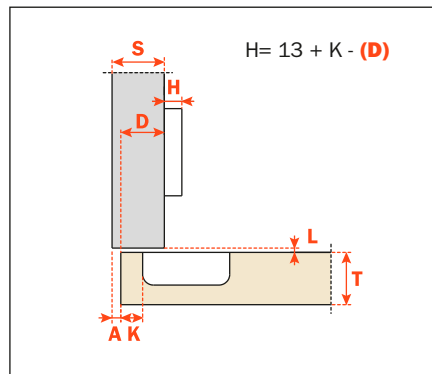
**CA - C3\_BA99**



## Series 800





**Bright nickel plated steel cup and arm.**  
**Dimensions of the Ø 35 mm cup.**

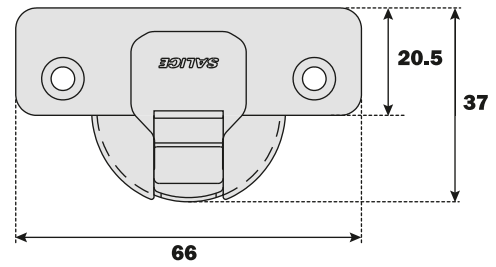

Approx. number of hinges required according to the door dimension and weight.

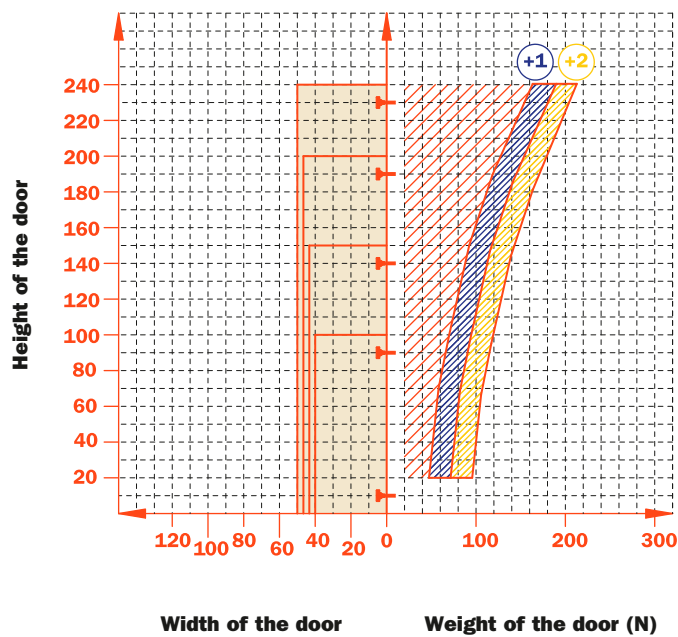

### Adjustments

Side adjustment from -1.5 mm to +4.5 mm.  
 Height adjustment  $\pm 2$  mm.  
 Depth adjustment from -1.5 mm to +3 mm.

### Mounting plates

Symmetrical and asymmetrical bright nickel plated steel Series 200 mounting plates.  
**NOT COMPATIBLE** with Series 200 die-cast mounting plates.

N.B. : Use POZIDRIVE No. 2 screwdrivers for all screws.

<b>Wood screw</b> 	<b>A</b>	<b>P</b>	<b>U</b>
<b>Rapido</b> 	<b>6</b>	<b>7</b>	<b>2</b>
<b>Dowel</b> 	<b>B</b>	<b>R</b>	<b>W</b>
<b>Logica</b> 	<b>I</b>	<b>J</b>	<b>Q</b>

Use this table to identify the available drillings and fixings.

Fill the third position of the hinge code number with the letter or the number corresponding to your choice. I.e.: C8\_6C99.



Fill this position with the chosen letter or number.



**Technical information**

When a greater opening angle is required.  
 11 mm deep metal cup.  
 110° opening.  
 Possible drilling distance on the door (K): from 3 to 6 mm.  
 Compatible with all traditional steel Series 200 mounting plates.

**Space needed to open the door**

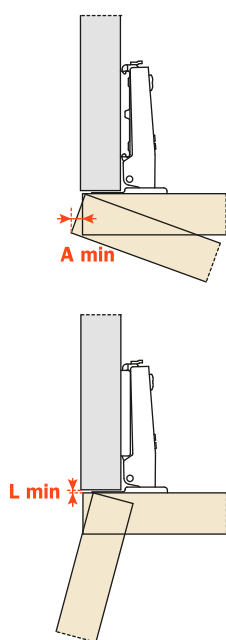

	T=	16	17	18	19	20	21	22	23	24	25	26
K=3	<b>A=</b>	0.5	0.7	0.9	1.2	1.5	1.8	2.4	3.7	5.1	6.5	7.8
K=4	<b>A=</b>	0.5	0.7	0.9	1.2	1.5	1.8	2.1	2.7	4.1	5.5	6.8
K=5	<b>A=</b>	0.5	0.7	0.9	1.2	1.5	1.8	2.1	2.6	3.1	4.1	5.4
K=6	<b>A=</b>	0.5	0.7	0.9	1.2	1.5	1.8	2.1	2.5	3.0	3.5	4.4

	T=	16	17	18	19	20	21	22	23	24	25	26
K=3	<b>L=</b>	0.0	0.0	0.0	0.0	0.2	0.5	0.8	1.1	1.4	1.7	1.9
K=4	<b>L=</b>	0.0	0.0	0.3	0.6	0.9	1.2	1.4	1.7	2.0	2.3	2.6
K=5	<b>L=</b>	1.1	1.3	1.6	1.8	2.1	2.3	2.6	2.9	3.1	3.4	3.6
K=6	<b>L=</b>	2.0	2.3	2.5	2.8	3.1	3.3	3.6	3.8	4.3	4.3	4.6

The above values are calculated on the assumption that the doors have square edges. They are reduced if the doors have radiused edges.

**Projection of the door**

Projection of the door from the cabinet side at the max. opening. The figures are based on a straight arm hinge, H=0 mm thickness of mounting plate and K value = 3 mm.

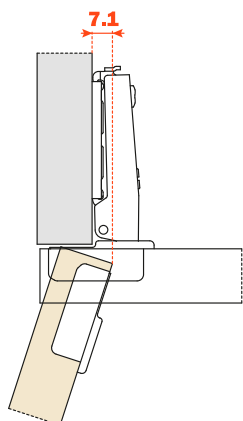

**“C” value**

With this formula you can obtain the max. thickness of the moulded door that can be opened without touching adjacent carcass sides, doors or walls, whilst bearing in mind the above L-K-T values.

$C = 20 + K + A$

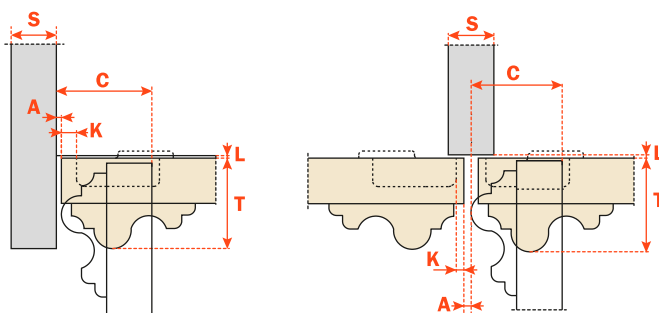

**Packing**

Boxes 300 pcs.  
Pallets 7.200 pcs.

**CA** sprung hinge  
**CL** unsprung hinge

Use these formulas to determine the type of hinge arm, the drilling distance "K" and the height of the mounting plate "H" which is necessary to solve each application problem.

Use the tables "Drillings and fixings" at page 125 to complete the code number of the desired hinge.

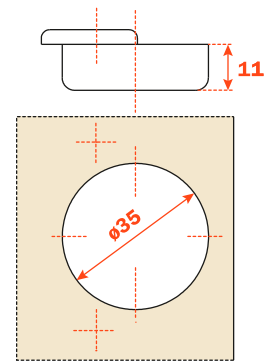
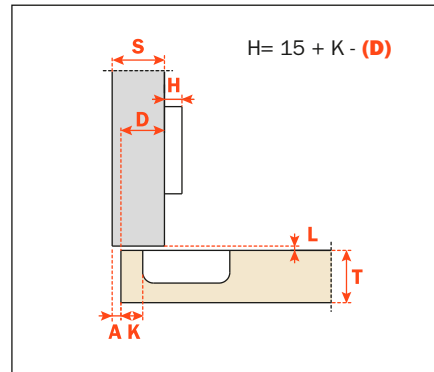
**Arm 0**

**CA - C8\_6C99**  
**CL - C8\_4C99**

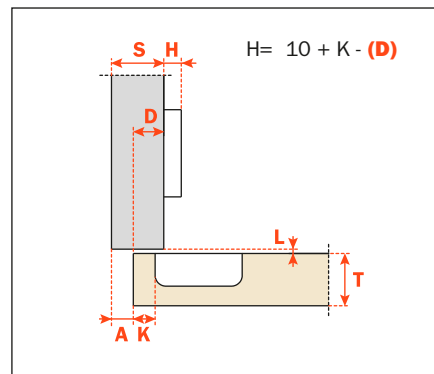
**Arm 5**

**CA - C8\_6J99**  
**CL - C8\_4J99**

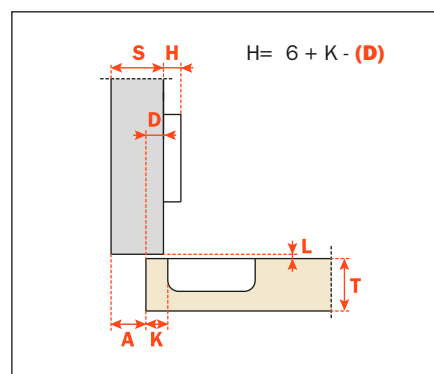
**Arm 9**

**CA - C8\_6L99**  
**CL - C8\_4L99**

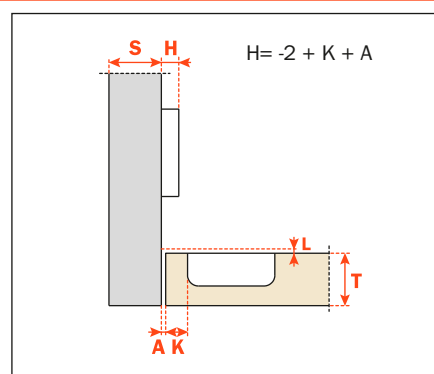
**Arm 17**

**CA - C8\_7S99**  
**CL - C8\_5S99**

**94° Opening**



## Series 900





Bright nickel plated steel cup and arm.  
Dimensions of the Ø 35 mm cup.

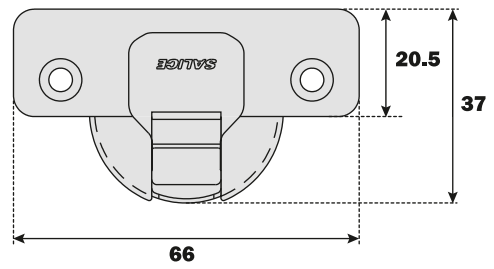

Approx. number of hinges required according to the door dimension and weight.

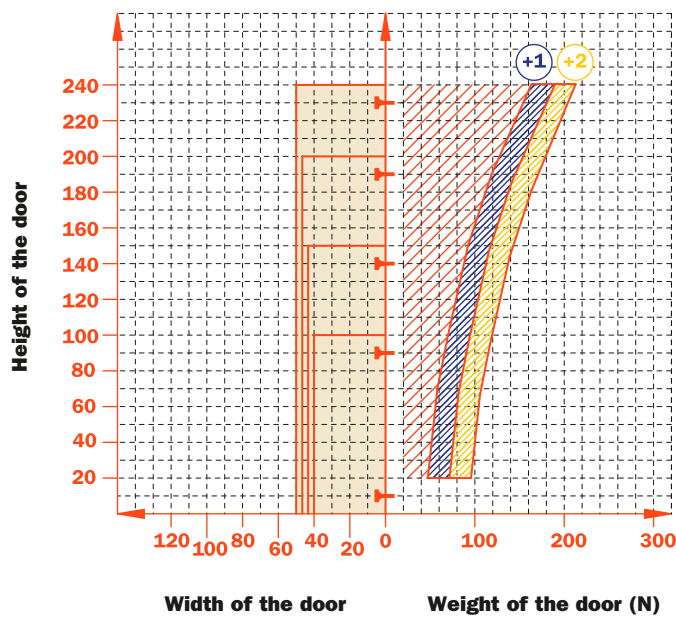

**Adjustments**

Side adjustment from -1.5 mm to +4 mm.  
Height adjustment ±2 mm.  
Depth adjustment +2.5 mm.

**Mounting plates**

Symmetrical and asymmetrical bright nickel plated steel or die-cast Series 200 mounting plates.  
**NOT COMPATIBLE** with Series 200 mounting plates with negative height.

N.B. : Use POZIDRIVE No. 2 screwdrivers for all screws.

## Drillings and fixings

<b>Wood screw</b>		<b>A</b>	<b>A</b>	<b>P</b>	<b>P</b>	<b>U</b>	<b>U</b>
<b>Rapido</b>		<b>6</b>	<b>6</b>	<b>7</b>	<b>7</b>	<b>2</b>	<b>2</b>
<b>Dowel</b>		<b>B</b>	<b>B</b>	<b>R</b>	<b>R</b>	<b>W</b>	<b>W</b>
<b>Logica</b>		<b>I</b>	<b>I</b>	<b>J</b>	<b>J</b>	<b>Q</b>	<b>Q</b>

Use this table to identify the available drillings and fixings.

Fill the third position of the hinge code number with the letter or the number corresponding to your choice. I.e.: C9\_7C99.

↑  
Fill this position with the chosen letter or number.



**Technical information**

**For doors with a maximum thickness of 32mm, with moulded profiles.**

11 mm deep metal cup.

94° opening.

Possible drilling distance on the door (K): from 3 to 8 mm.

Compatible with all traditional Series 200 mounting plates.

**NOT COMPATIBLE** with Domi snap-on mounting plates.

**Space needed to open the door**

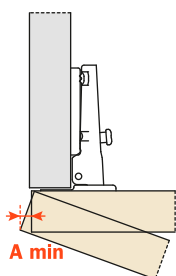

T=	16	18	20	22	24	26	28	30	32
K=3	<b>A=</b> 0.4	0.8	1.2	1.7	2.4	3.2	4.5	6.3	8.1
K=4	<b>A=</b> 0.4	0.7	1.2	1.7	2.3	3.1	4.2	5.6	7.5
K=5	<b>A=</b> 0.4	0.7	1.1	1.6	2.3	3.0	3.9	5.3	7.0
K=6	<b>A=</b> 0.4	0.7	1.1	1.6	2.2	2.9	3.8	5.0	6.5
K=7	<b>A=</b> 0.4	0.7	1.1	1.6	2.1	2.8	3.7	4.7	6.1
K=8	<b>A=</b> 0.4	0.7	1.1	1.5	2.1	2.8	3.6	4.5	5.8

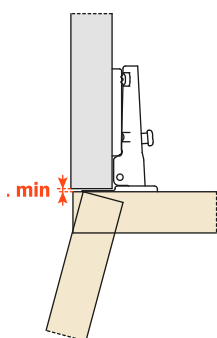

K=	3	4	5	6	7	8
<b>L=</b>	0.0	0.0	0.0	0.0	0.0	0.1

The above values are calculated on the assumption that the doors have square edges. They are reduced if the doors have radiussed edges.

**Projection of the door**

Projection of the door from the cabinet side at the max. opening. The figures are based on a straight arm hinge, H=0 mm thickness of mounting plate and K value = 3 mm.

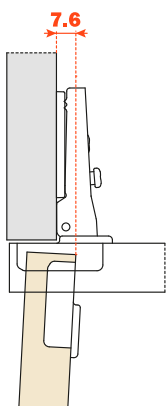

**“C” value**

With this formula you can obtain the max. thickness of the moulded door that can be opened without touching adjacent carcass sides, doors or walls, whilst bearing in mind the above L-K-T values.

$$C = 22.5 + K + A$$

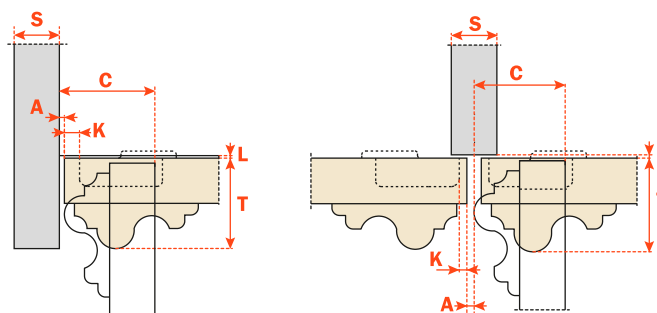

**Packing**

Boxes 300 pcs.  
Pallets 7.200 pcs.

Use these formulas to determine the type of hinge arm, the drilling distance "K" and the height of the mounting plate "H" which is necessary to solve each application problem.

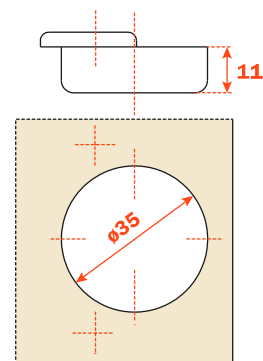
**CA sprung hinge**

Use the tables "Drillings and fixings" at page 131 to complete the code number of the desired hinge.

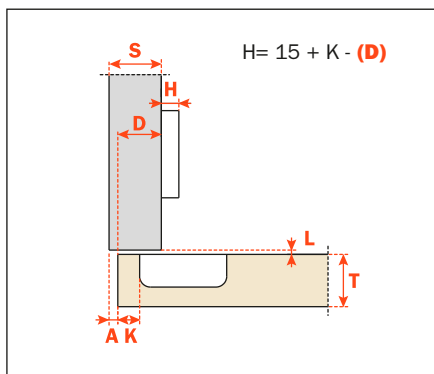
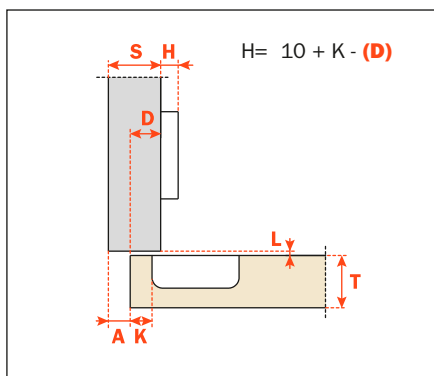
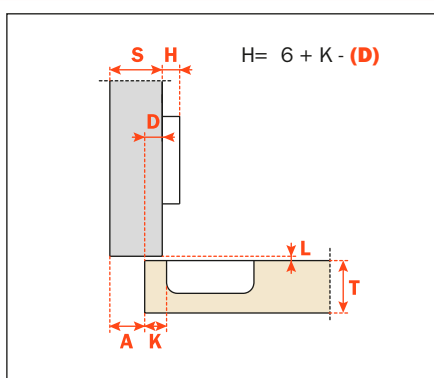
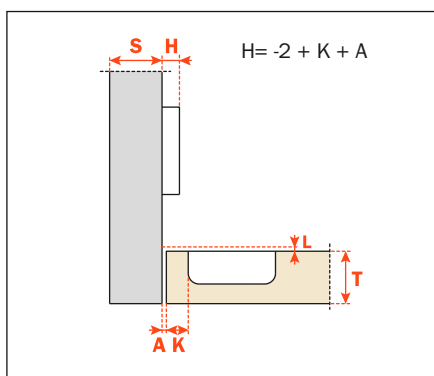
**Arm 0****CA - C9\_7C99****Arm 5****CA - C9\_7J99****Arm 9****CA - C9\_7L99****Arm 17****CA - C9\_7S99**



**Technical information**

**For doors with a minimum thickness of 13mm, or with moulded profiles.**

11 mm deep metal cup.

110° opening.

Possible drilling distance on the door (K): from 3 to 6 mm.

Compatible with all traditional Series 200 mounting plates.

**NOT COMPATIBLE** with Domi snap-on mounting plates.

**Space needed to open the door**

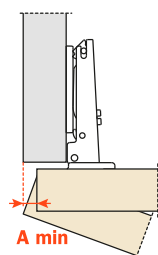

	T=	16	17	18	19	20	21	22	23	24	25	26
K=3	<b>A=</b>	0.5	0.7	0.9	1.2	1.5	1.8	2.4	3.7	5.1	6.5	7.8
K=4	<b>A=</b>	0.5	0.7	0.9	1.2	1.5	1.8	2.1	2.7	4.1	5.5	6.8
K=5	<b>A=</b>	0.5	0.7	0.9	1.2	1.5	1.8	2.1	2.6	3.1	4.1	5.4
K=6	<b>A=</b>	0.5	0.7	0.9	1.2	1.5	1.8	2.1	2.5	3.0	3.5	4.4

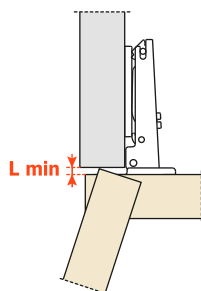

	T=	16	17	18	19	20	21	22	23	24	25	26
K=3	<b>L=</b>	0.0	0.0	0.0	0.0	0.2	0.5	0.8	1.1	1.4	1.7	1.9
K=4	<b>L=</b>	0.0	0.0	0.3	0.6	0.9	1.2	1.4	1.7	2.0	2.3	2.6
K=5	<b>L=</b>	1.1	1.3	1.6	1.8	2.1	2.3	2.6	2.9	3.1	3.4	3.6
K=6	<b>L=</b>	2.0	2.3	2.5	2.8	3.1	3.3	3.6	3.8	4.3	4.3	4.6

The above values are calculated on the assumption that the doors have square edges. They are reduced if the doors have radiussed edges.

**Projection of the door**

Projection of the door from the cabinet side at the max. opening. The figures are based on a straight arm hinge, H=0 mm thickness of mounting plate and K value = 3 mm.

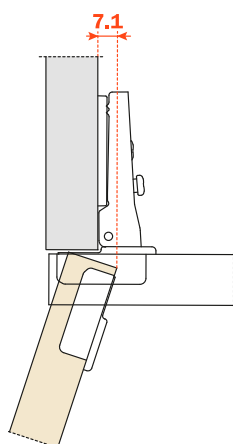

**“C” value**

With this formula you can obtain the max. thickness of the moulded door that can be opened without touching adjacent carcass sides, doors or walls, whilst bearing in mind the above L-K-T values.

$$C = 20 + K + A$$

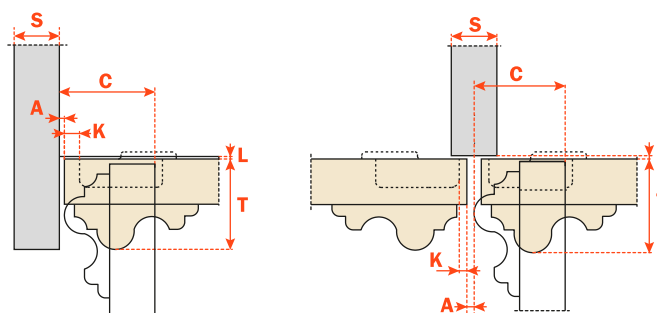

**Packing**

Boxes 300 pcs.  
Pallets 7.200 pcs.

Use these formulas to determine the type of hinge arm, the drilling distance "K" and the height of the mounting plate "H" which is necessary to solve each application problem.

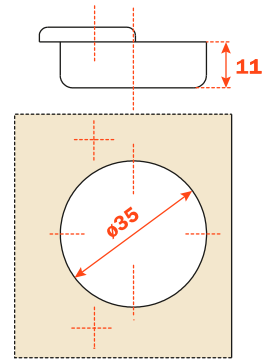
**CA sprung hinge**

Use the tables "Drillings and fixings" at page 131 to complete the code number of the desired hinge.

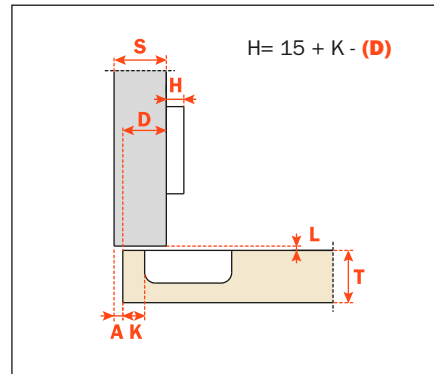
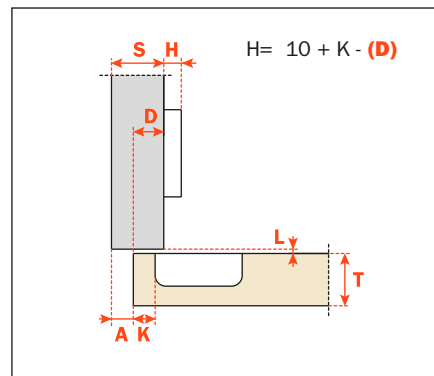
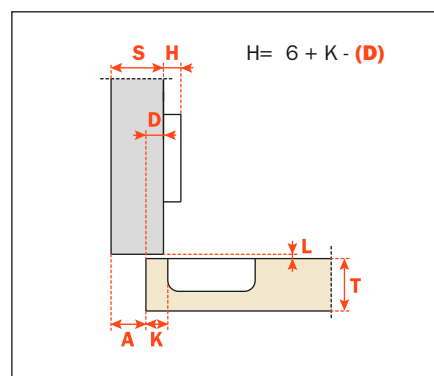
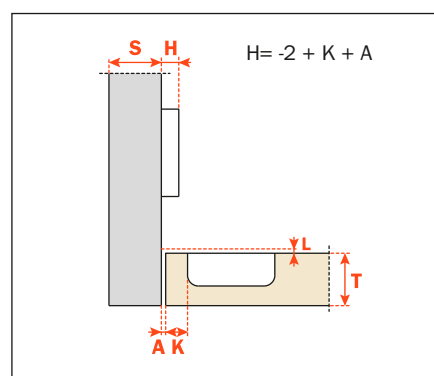
**Arm 0****CA - C9\_6C99****Arm 5****CA - C9\_6J99****Arm 9****CA - C9\_6L99****Arm 17****CA - C9\_6S99**





## For metal profiles



For metal profiles



**Technical information**

**Hinges for the Practical system have been developed for use with special metal profiles. The particular fixing system does not require any profile working.**

The hinge can be therefore assembled at any point of the frame. 105° opening.  
Compatible with all traditional Series 200 mounting plates and with all Domi snap-on mounting plates.

**Packing**

Boxes 150 pcs.  
Pallets 3.600 pcs.

**CA** sprung hinge

**Arm 0**

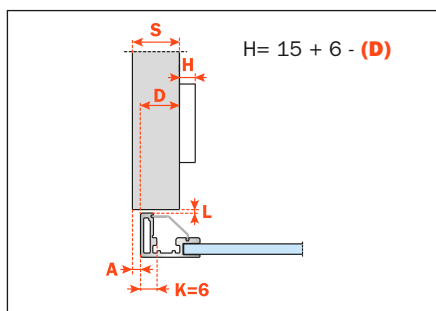

**CA - C206A99**

**Arm 5**

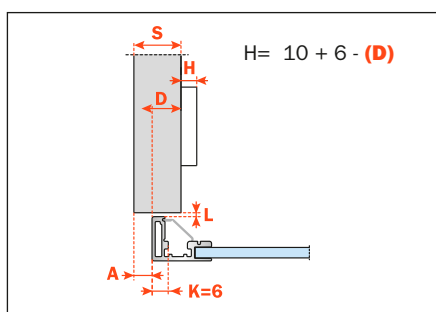

**CA - C206D99**

**Arm 9**

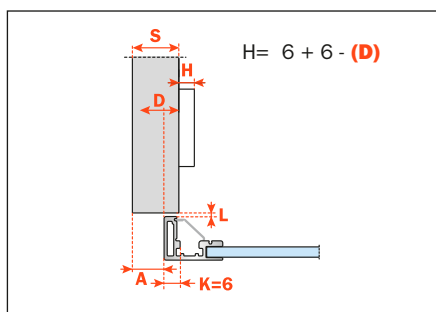

**CA - C206G99**

**Arm 17**

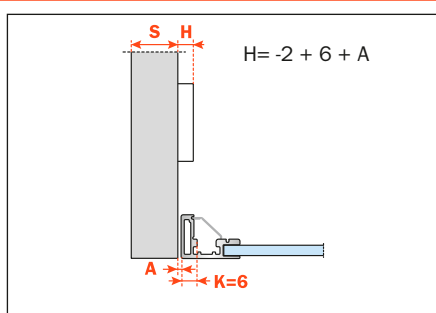

**CA - C206P99**



**Technical information**

Hinges for doors with positive angled assembly.  
 Hinges for the Practical system have been developed for use with special metal profiles.  
 The particular fixing system does not require any profile working.

The hinge can be therefore assembled at any point of the frame.  
 105° opening.

Compatible with all traditional Series 200 mounting plates and with all Domi snap-on mounting plates.

**Packing**

Boxes 150 pcs.  
 Pallets 3.600 pcs.

CA sprung hinge

Arm 30°

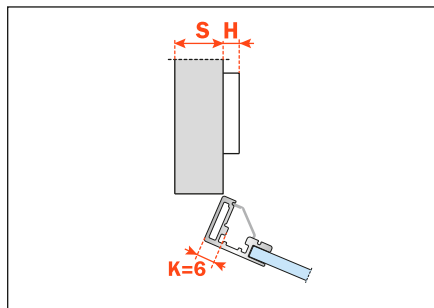

CA - C206E99

Arm 45°

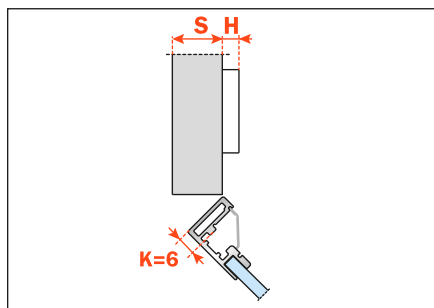

CA - C206M99

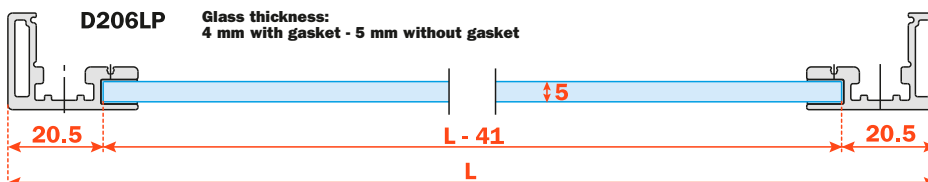
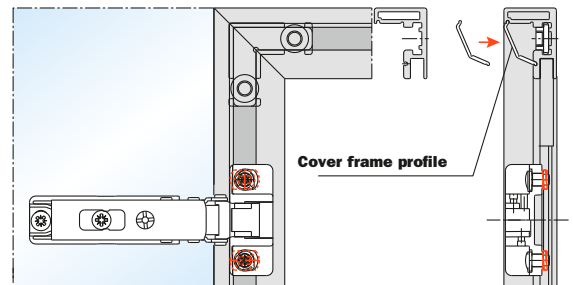
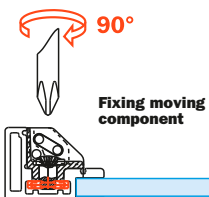
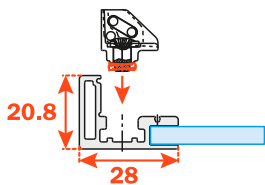



**Technical information**

**Crampon hinges.**  
**For cabinet sides with 37x32 mm standard drilling.**  
**Hinges for the Practical system have been developed for use with special metal profiles.**  
**The particular fixing system does not require any profile working.**

The hinge can be therefore assembled at any point of the frame.  
 105° opening.  
 Compatible with all traditional Series 200 mounting plates and with all Domi snap-on mounting plates.

**Packing**

Boxes 150 pcs.  
 Pallets 3.600 pcs.

**E min:**

61 mm for Series 200 mounting plates.  
 70 mm for Domi snap-on mounting plates.  
 74 mm for Domi snap-on mounting plates with back cam.

**CA sprung hinge**

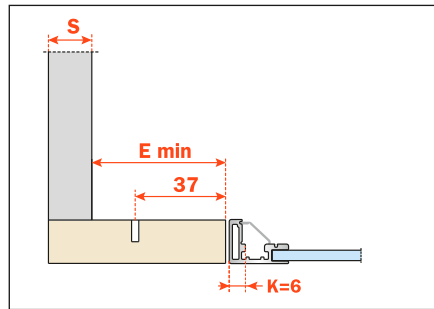

**CA - C206N99AC**

Heights of mounting plates for every assembly.

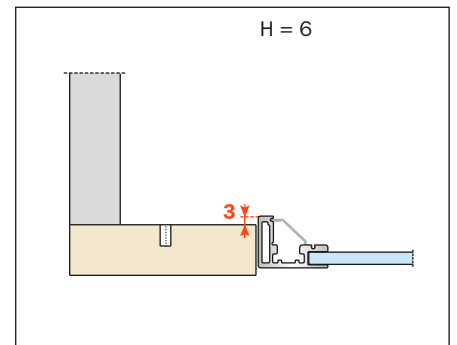
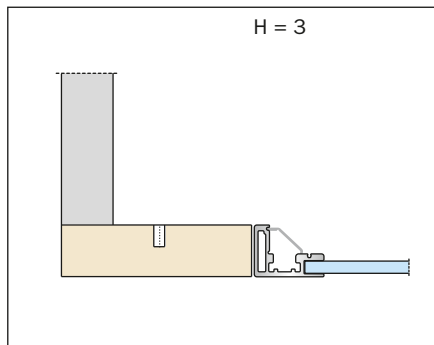
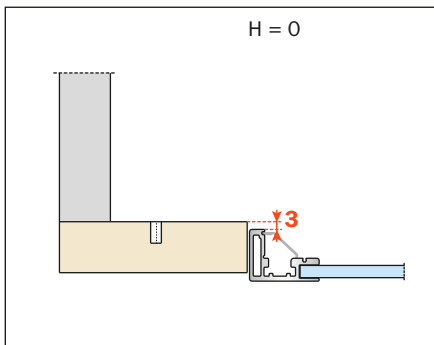



**Technical information**

**Crampon hinges.**

**For smaller spaces with 15x32 mm drilling.**

**Hinges for the Practical system have been developed for use with special metal profiles.**

**The particular fixing system does not require any profile working.**

The hinge can be therefore assembled at any point of the frame. 105° opening.

Compatible with all traditional Series 200 mounting plates, 28x32 mm drilling.

**NOT COMPATIBLE** with Domi snap-on mounting plates.

**Packing**

Boxes 150 pcs.

Pallets 3.600 pcs.

**CA** sprung hinge

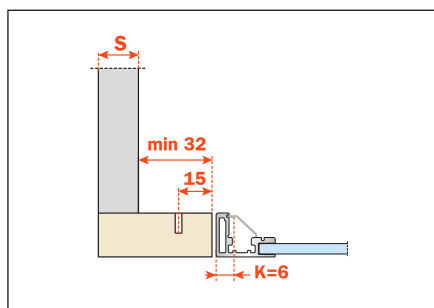

**CA - C206N99**

Heights of mounting plates for every assembly.

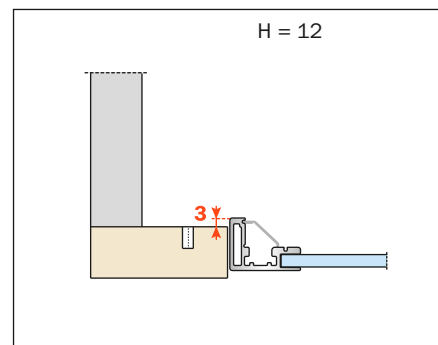
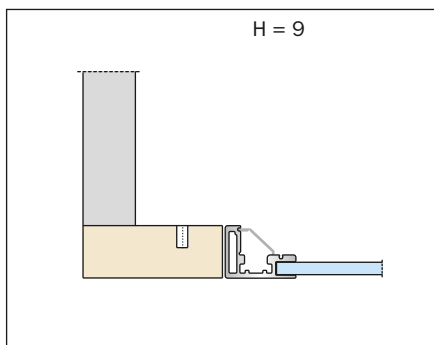
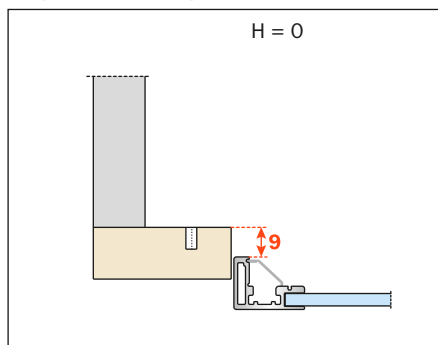

## D206BS5



Corner connector with 2 fixing screws for the frame assembly

**Packing**  
Boxes 600 pcs.

## D206BS5L



Corner connector with 4 fixing screws for the frame assembly

**Packing**  
Boxes 600 pcs.

## D206HS5



Additional corner connector for the frame assembly

**Packing**  
Boxes 600 pcs.

## D206AG3000



Gasket for glass  
3 m lengths

**Packing**  
Boxes 120 pcs.

## D206LP3000

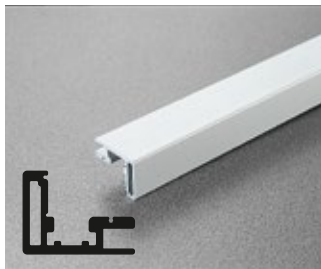

Frame for doors, glass to be inserted

3 m lengths

**Packing**  
Boxes 12 pcs.

## D206BL5



Adapter for single flap doors, drawer frontals and special applications

**Packing**  
Boxes 150 pcs.

## D206AA3000



Internal cover frame profile of moulded plastic

3 m lengths

**Packing**  
Boxes 120 pcs.



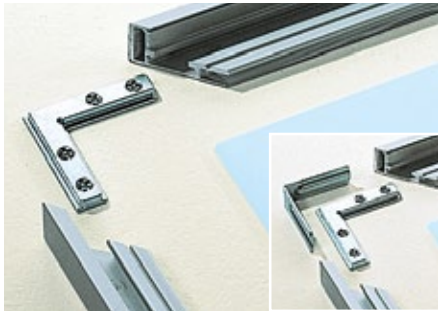

**1)** The profiles which make up the door are cut to length and the ends mitted at 45°.



**2)** Insert the corner connector into the profile, recess and fix it by means of its premounted screw/screws. On large doors it is suggested to use the additional corner connector (small picture).



**3)** Repeat the same operation on the other profiles which make up the door. The glass will be applied before fixing the fourth and last profile.



**4)** Fix the hinges to the mounting plates and then assemble them onto the frame. The operation does not require any work on the door, as the hinge can be inserted at any point of the profile recess.



**5)** The hinge will be therefore at the exact position of the mounting plate on the cabinet side.



**6)** At this point it is sufficient to fix the hinge onto the profile by simply rotating the cams 90°.



**7)** Cut to length and mitre the internal frame cover profile also.



**8)** Complete the preparation of the door by inserting the internal frame cover profile with a simple pressure.

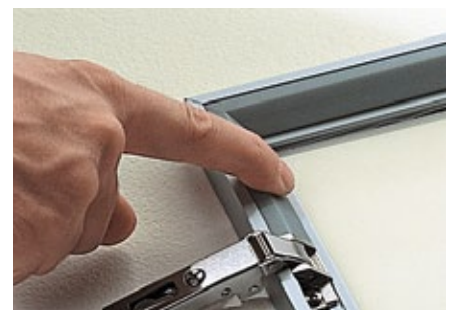

**9)** Where the hinges are located, cut the internal frame cover profile at the position of the same hinges.



**10)** Internal frame cover profile, moulded version.

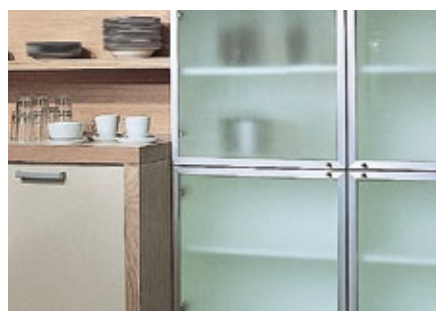

**11)** Hinges for the Practical system represent the most practical, quickest and elegant solution for all types of furniture.



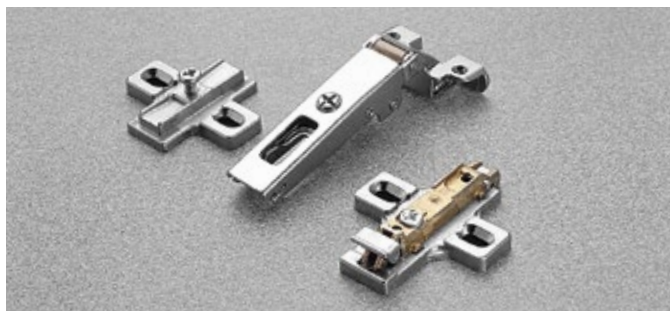

**Technical information**

**Hinges specially developed for use with metal profiles.**  
105° opening.

We recommend the use of self-threading screws B 3.5 x 9.5  
DIN 7982 to fix C2Z6 hinges.

Compatible with all traditional Series 200 mounting plates and  
with all Domi snap-on mounting plates.

**Packing**

Boxes 150 pcs.

Pallets 3.600 pcs.

**CA** sprung hinge

**Arm 0**

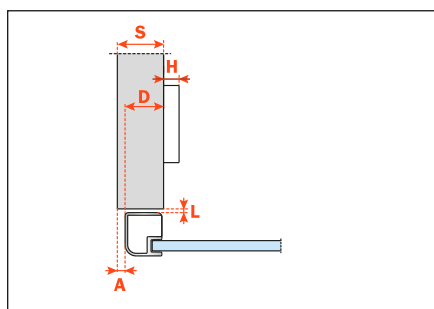

**CA - C2Z6A99**

**Arm 5**

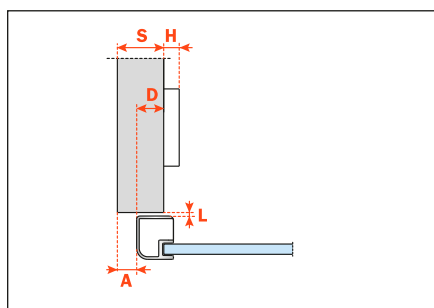

**CA - C2Z6D99**

**Arm 9**

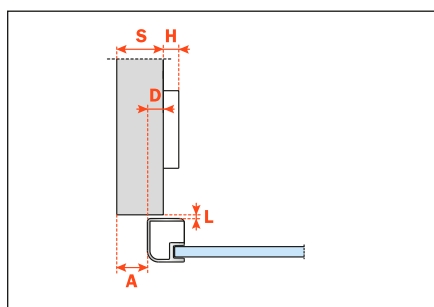

**CA - C2Z6G99**

**Arm 17**

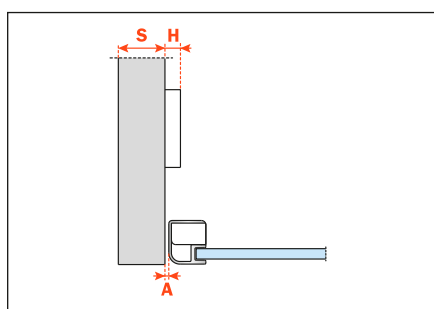

**CA - C2Z6P99**



**Technical information**

**Hinges for doors with positive angled assembly.**  
**Hinges specially developed for use with metal profiles.**  
 105° opening.

We recommend the use of self-threading screws B 3.5 x 9.5  
 DIN 7982 to fix C2Z6 hinges.

Compatible with all traditional Series 200 mounting plates and  
 with all Domi snap-on mounting plates.

**Packing**

Boxes 150 pcs.  
 Pallets 3.600 pcs.

**CA** sprung hinge

Arm 30°

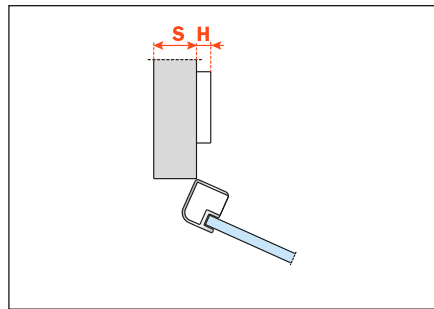

**CA - C2Z6E99**

Arm 45°

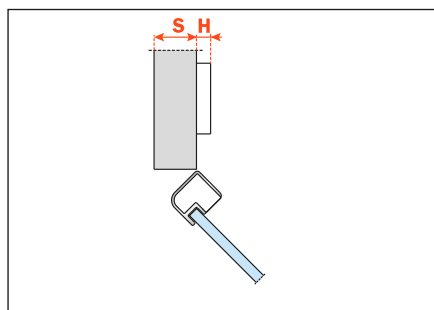

**CA - C2Z6M99**

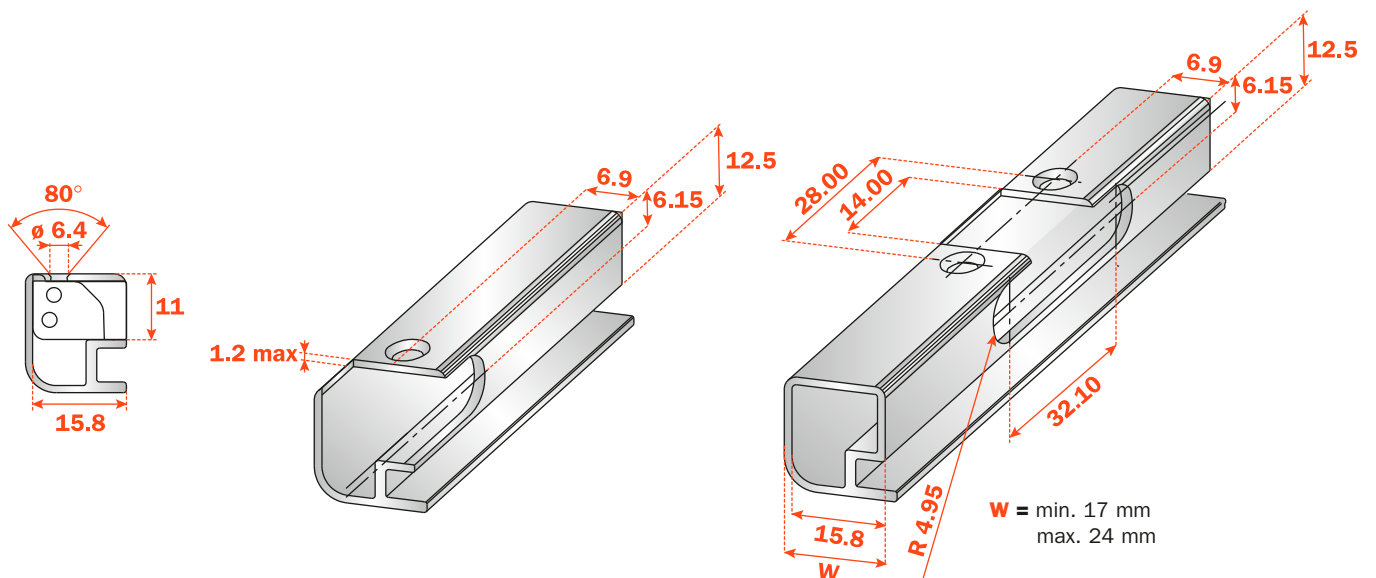



**Technical information**

**Crampon hinges.**  
**For cabinet sides with 37x32 mm standard drilling.**  
**Hinges specially developed for use with metal profiles.**  
 105° opening.  
 We recommend the use of self-threading screws B 3.5 x 9.5 DIN 7982 to fix C2Z6 hinges.  
 Compatible with all traditional Series 200 mounting plates and with all Domi snap-on mounting plates.

**Packing**

Boxes 150 pcs.  
 Pallets 3.600 pcs.

**E min:**

61 mm for Series 200 mounting plates.  
 70 mm for Domi snap-on mounting plates.  
 74 mm for Domi snap-on mounting plates with back cam.

**CA sprung hinge**

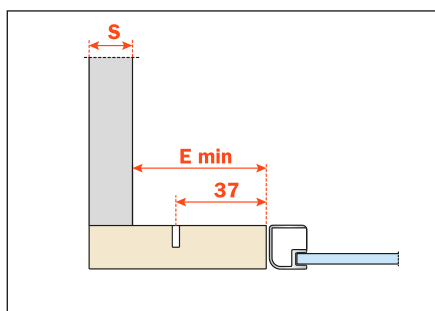

**CA - C2Z6N99AC**

Heights of mounting plates for every assembly.

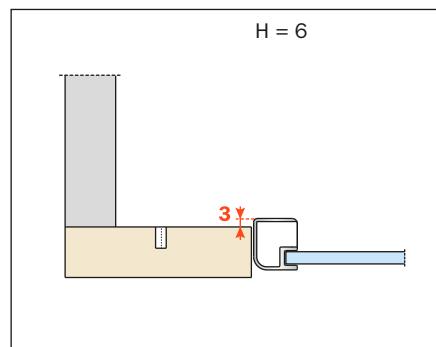
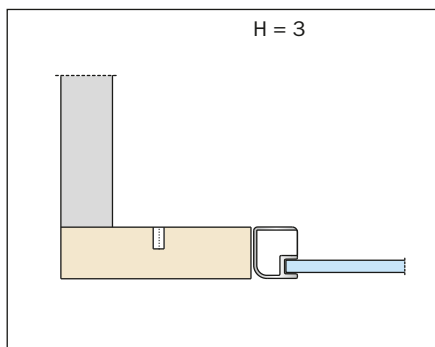
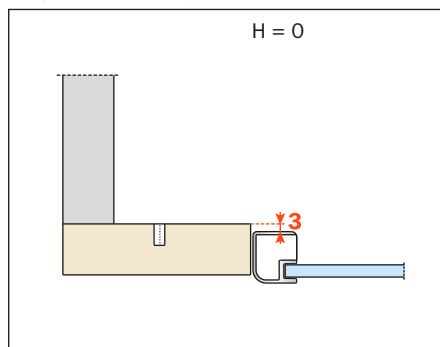



### Technical information

**Crampon hinges.**  
**For smaller spaces with 15x32 mm drilling.**  
**Hinges specially developed for use with metal profiles.**

105° opening.  
 We recommend the use of self-threading screws B 3.5 x 9.5  
 DIN 7982 to fix C2Z6 hinges.  
 Compatible with all traditional Series 200 mounting plates, drilling  
 28x32 mm.

**NOT COMPATIBLE** with Domi snap-on mounting plates.

### Packing

Boxes 150 pcs.  
 Pallets 3.600 pcs.

CA sprung hinge

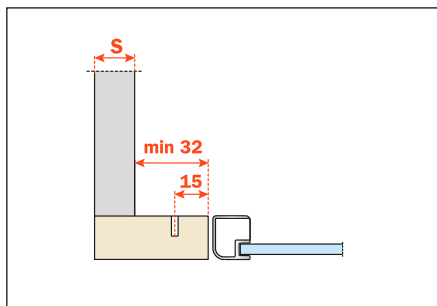

**CA - C2Z6N99**

Heights of mounting plates for every assembly.

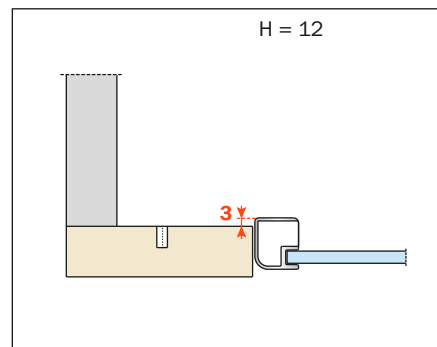
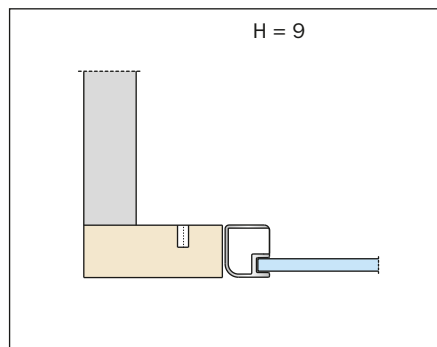
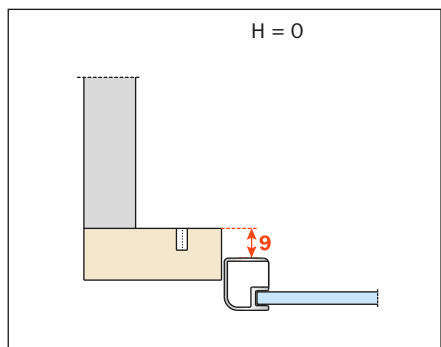



**Technical information**

**Hinges specially developed for use with metal profiles, with spring-cover cup.**

94° opening.

Compatible with all traditional Series 200 mounting plates and with all Domi snap-on mounting plates.

**Packing**

Boxes 150 pcs.

Pallets 3.600 pcs.

**CA** sprung hinge

**Arm 0**

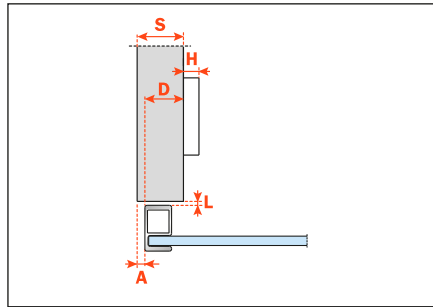

**CA - C4Z7A99**

**Arm 5**

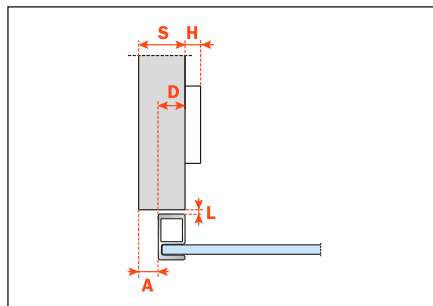

**CA - C4Z7D99**

**Arm 9**

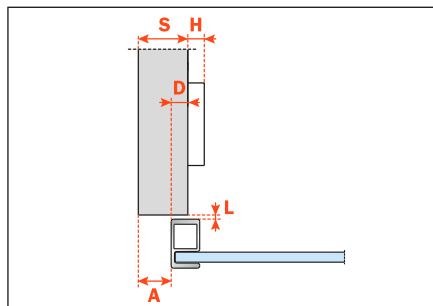

**CA - C4Z7G99**

**Arm 17**

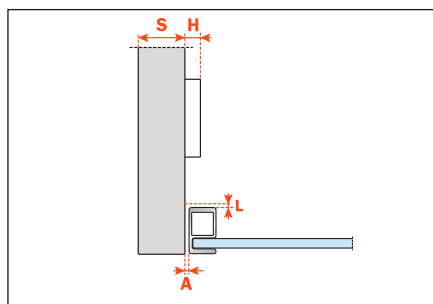

**CA - C4Z7P99**





**Technical information**

**Hinges for doors with positive angled assembly and crampon hinges.**

**Hinges specially developed for use with metal profiles, with spring-cover cup.**

94° opening.

Compatible with all traditional Series 200 mounting plates and with all Domi snap-on mounting plates.

**Packing**

Boxes 150 pcs.

Pallets 3.600 pcs.

CA sprung hinge

**Arm 30°**

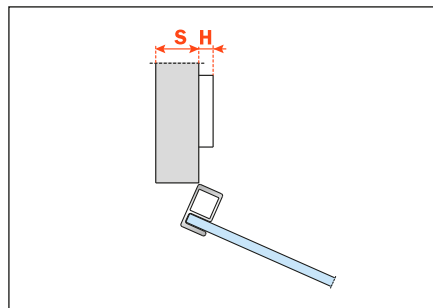

**CA - C4Z7E99**

**Arm 45°**

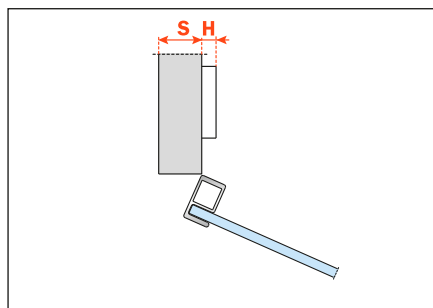

**CA - C4Z7M99**

**Crampon**

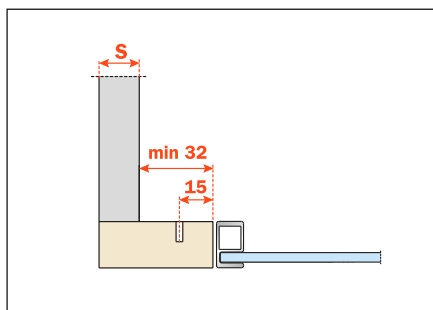

**Crampon hinges.** To be used only with Series 200 mounting plates for traditional assembly and drilling 28x32 mm.

**CA - C4Z7N99**

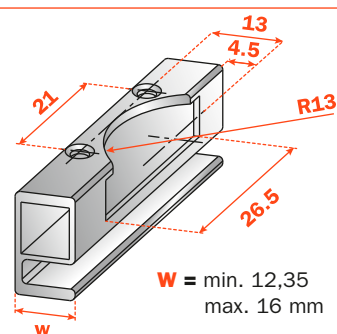
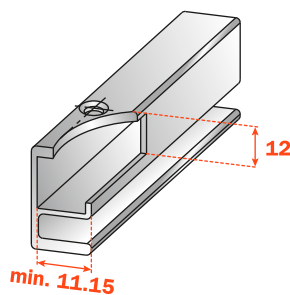
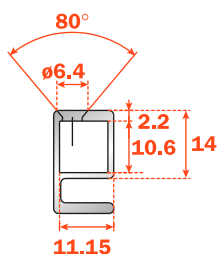





## Mini hinges - Series 400



**Compact, elegant, very strong mini hinge.**  
**Bright nickel plated steel cup.**  
**Bright nickel plated die-cast arm.**  
**Dimensions of the  $\varnothing$  26 mm cup.**

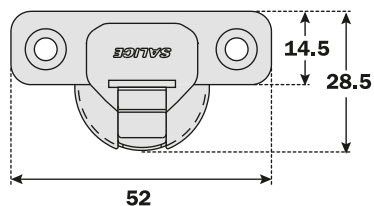

Constant "L" value of 0.7 mm (it does not change during side adjustment).

Approx. number of hinges required according to the door dimension and weight.

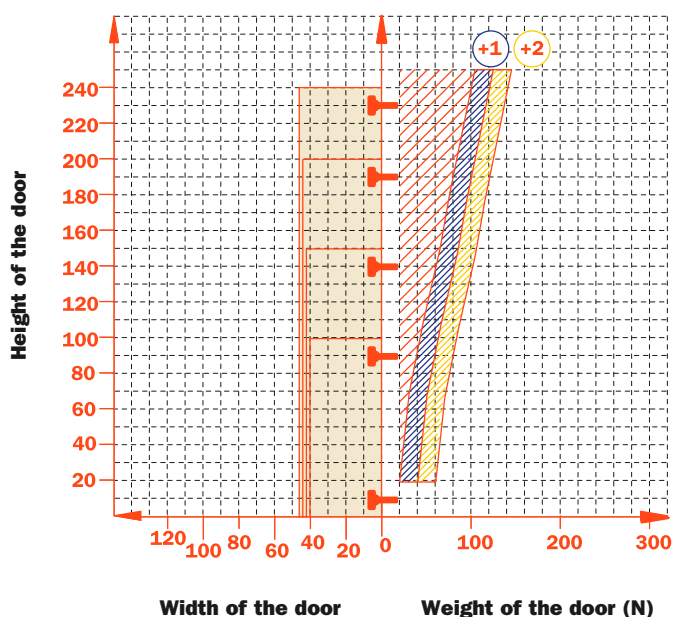





### Adjustments

Compensated side adjustment from -0.5 mm to +5.5 mm.  
 Height adjustment  $\pm 2$  mm.  
 Depth adjustment with Series 200 mounting plates +2.8 mm.  
 Depth adjustment with Domi mounting plates from -0.5 mm to +2.8 mm.

### Mounting plates

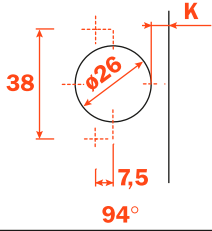
Symmetrical and asymmetrical bright nickel plated steel or die-cast Series 200 mounting plates.  
 Snap-on assembly on series Domi mounting plates.  
 Positioning with pre-determined stop on traditional Series 200 mounting plates.

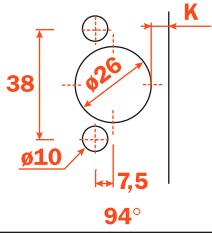
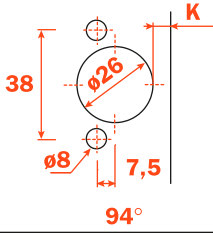
N.B. : Use POZIDRIVE No. 2 screwdrivers for all screws.

		
<p>Wood screw</p> 	<p>A</p>	
		
<p>Dowel</p> 	<p>B</p>	<p>R</p>

Use this table to identify the available drillings and fixings.  
 Fill the third position of the hinge code number with the letter or the number corresponding to your choice. I.e.: C4\_7A99.

↑  
 Fill this position with the chosen letter or number.

# Mini hinges - Series 400 - 94° opening



## Technical information

11.5 mm deep metal cup.  
 26 mm cup diameter.  
 94° opening.  
 Possible drilling distance on the door (K): from 3 to 8 mm.  
 Compatible with all traditional Series 200 mounting plates and with all Domi snap-on mounting plates.

## Space needed to open the door

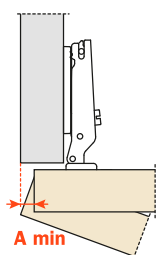

T=	16	17	18	19	20	21	22	23
K=3	<b>A=</b> 0.4	0.7	0.9	1.3	2.0	2.9	3.8	4.7
K=4	<b>A=</b> 0.4	0.6	0.9	1.1	1.6	2.4	3.3	4.2
K=5	<b>A=</b> 0.4	0.6	0.8	1.1	1.4	2.0	2.8	3.6
K=6	<b>A=</b> 0.4	0.6	0.8	1.0	1.2	1.8	2.4	3.2
K=7	<b>A=</b> 0.4	0.6	0.8	0.9	1.2	1.5	2.2	2.8
K=8	<b>A=</b> 0.4	0.6	0.8	0.9	1.2	1.5	1.9	2.6

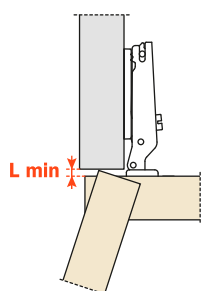

K=	3	4	5	6	7	8
<b>L=</b>	0.0	0.0	0.0	0.7	1.7	2.6

The above values are calculated on the assumption that the doors have square edges. They are reduced if the doors have radiussed edges.

## Projection of the door

Projection of the door from the cabinet side at the max. opening. The figures are based on a straight arm hinge, H=0 mm thickness of mounting plate and K value = 3 mm.

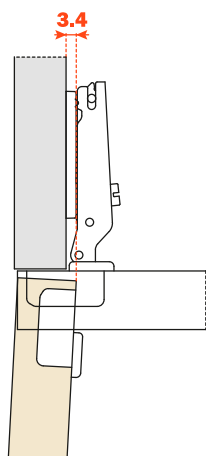

## "C" value

With this formula you can obtain the max. thickness of the moulded door that can be opened without touching adjacent carcass sides, doors or walls, whilst bearing in mind the above L-K-T values.

$$C = 16.5 + K + A$$

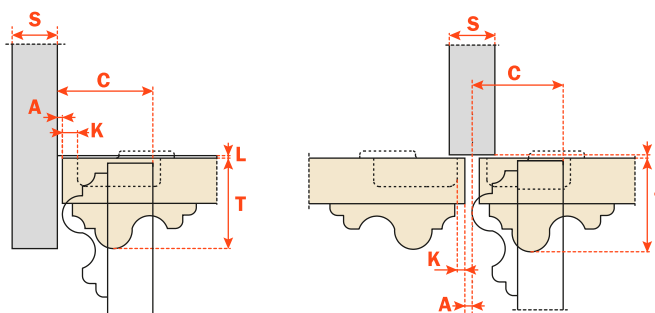

**Packing**

Boxes 300 pcs.  
Pallets 7.200 pcs.

Use these formulas to determine the type of hinge arm, the drilling distance "K" and the height of the mounting plate "H" which is necessary to solve each application problem.

Use the tables "Drillings and fixings" at page 153 to complete the code number of the desired hinge.

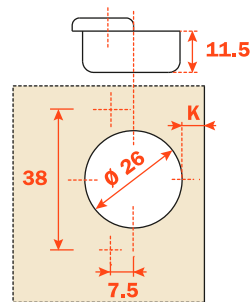
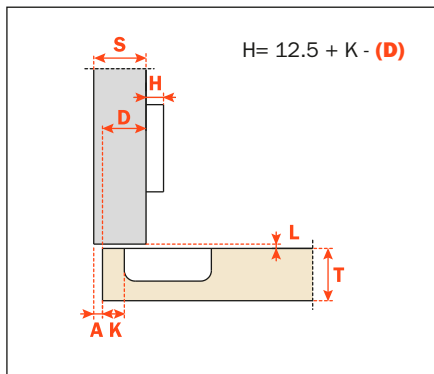
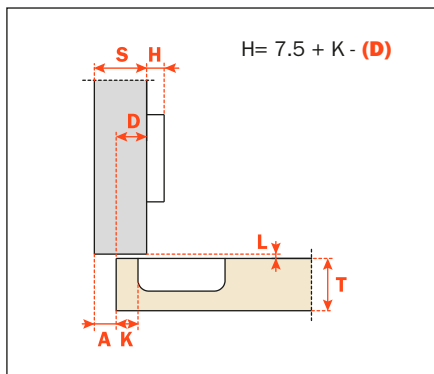
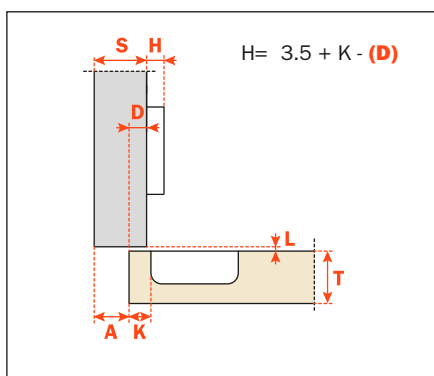
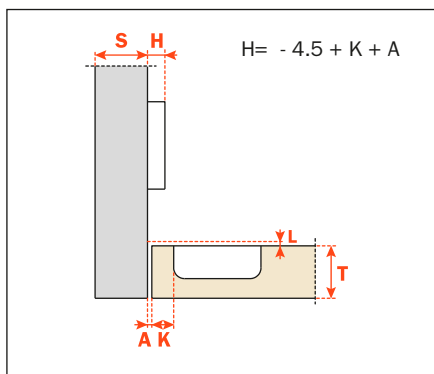
**CA sprung hinge****Arm 0****CA - C4\_7A99****Arm 5****CA - C4\_7D99****Arm 9****CA - C4\_7G99****Arm 17****CA - C4\_7P99**





## Technical information

### Hinges for doors with positive angled assembly and crampon hinges.

11.5 mm deep metal cup.  
 26 mm cup diameter.  
 94° opening.  
 Possible drilling distance on the door (K): from 3 to 8 mm.  
 Compatible with all traditional Series 200 mounting plates and with all Domi snap-on mounting plates.

### Packing

Boxes 150 pcs.  
 Pallets 3.600 pcs.

### CA sprung hinge

The solution of assembly problems where doors are mounted at a positive or negative angle requires the verification of drilling distances by a practical trial. Please do not hesitate to consult our technical support department for assistance.

Use the tables "Drillings and fixings" at page 153 to complete the code number of the desired hinge.

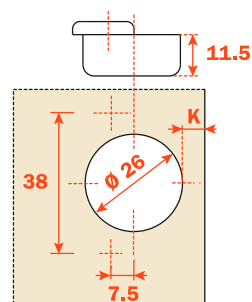

### Arm 30°

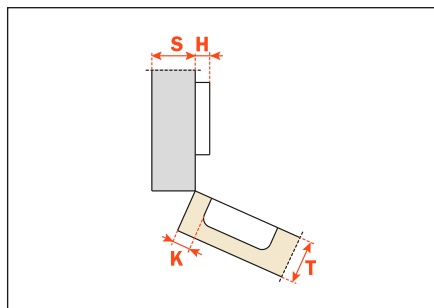

**CA - C4\_7E99**

### Arm 45°

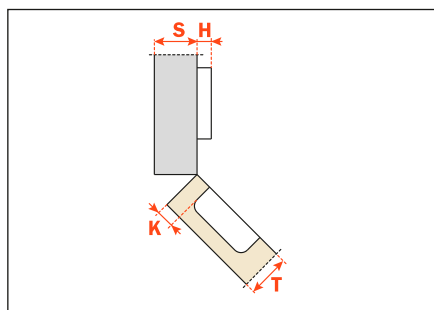

**CA - C4\_7M99**

### Crampon

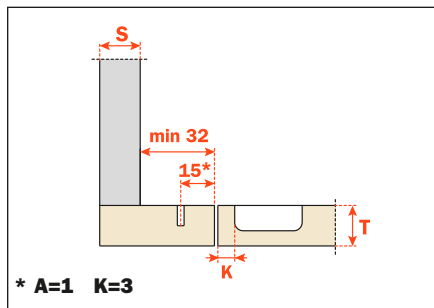

**Crampon hinge** to be used only with Series 200 mounting plates for traditional assembly and drilling 28x32mm.

**CA - C4\_7N99**

Heights of mounting plates for every assembly.

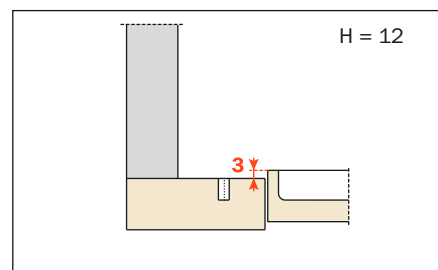
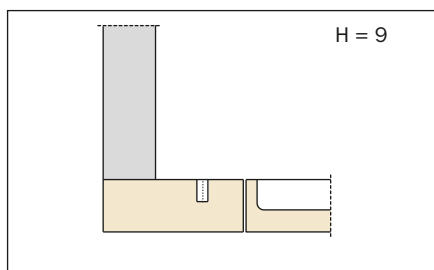
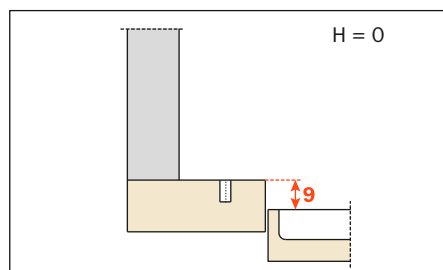

## Mini hinges - Series 600



**Compact, elegant, very strong mini hinge.  
Bright nickel plated steel cup and arm.  
Dimensions of the ø 26 mm cup.**

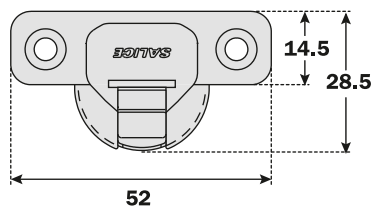

Constant "L" value of 0.7 mm (it does not change during side adjustment).

Approx. number of hinges required according to the door dimension and weight.

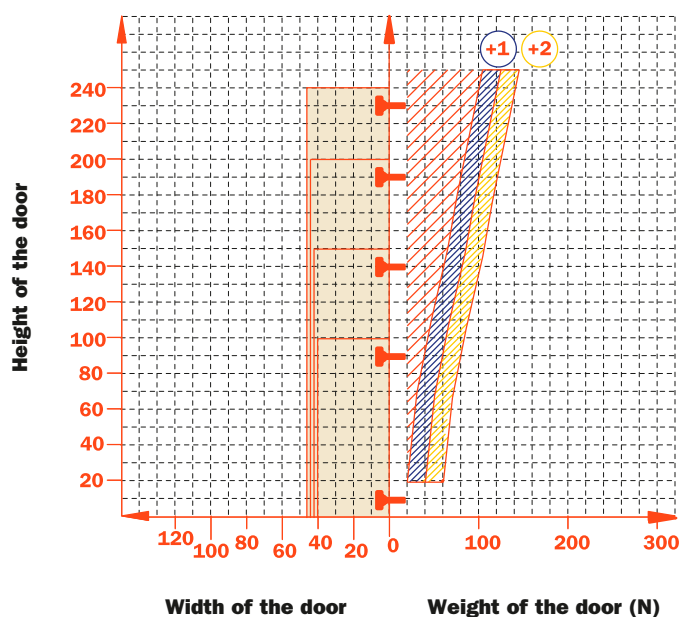

### Adjustments

Side adjustment +5 mm. It is possible to recover the gap behind the door (the initial "L" value of 0.7 mm) simply by using the assembly stop located on the underside of the hinge.  
Height adjustment  $\pm 2$  mm.  
Depth adjustment with Series 200 mounting plates +2.5 mm.

### Mounting plates

Symmetrical and asymmetrical bright nickel plated steel or die-cast Series 200 mounting plates.  
Positioning with pre-determined stop on Series 200 traditional mounting plates.  
**NOT COMPATIBLE** with Series 200 mounting plates with negative height.

N.B. : Use POZIDRIVE No. 2 screwdrivers for all screws.

Wood screw	
	A

Dowel		
	B	R

Use this table to identify the available drillings and fixings.

Fill the third position of the hinge code number with the letter or the number corresponding to your choice. I.e.: C6\_7C99.



Fill this position with the chosen letter or number.



## Technical information

11.5 mm deep metal cup.  
 26 mm cup diameter.  
 94° opening.  
 Possible drilling distance on the door (K): from 3 to 8 mm.  
 Compatible with all traditional Series 200 mounting plates.  
**NOT COMPATIBLE** with Domi snap-on mounting plates.

## Space needed to open the door

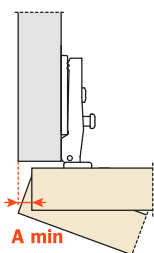

T=	16	17	18	19	20	21	22	23
K=3	<b>A=</b> 0.4	0.7	0.9	1.3	2.0	2.9	3.8	4.7
K=4	<b>A=</b> 0.4	0.6	0.9	1.1	1.6	2.4	3.3	4.2
K=5	<b>A=</b> 0.4	0.6	0.8	1.1	1.4	2.0	2.8	3.6
K=6	<b>A=</b> 0.4	0.6	0.8	1.0	1.2	1.8	2.4	3.2
K=7	<b>A=</b> 0.4	0.6	0.8	0.9	1.2	1.5	2.2	2.8
K=8	<b>A=</b> 0.4	0.6	0.8	0.9	1.2	1.5	1.9	2.6

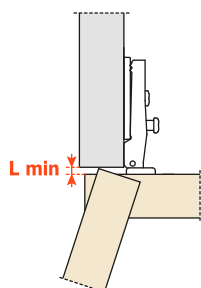

K=	3	4	5	6	7	8
<b>L=</b>	0.0	0.0	0.0	0.7	1.7	2.6

The above values are calculated on the assumption that the doors have square edges. They are reduced if the doors have radiussed edges.

## Projection of the door

Projection of the door from the cabinet side at the max. opening. The figures are based on a straight arm hinge, H=0 mm thickness of mounting plate and K value = 3 mm.

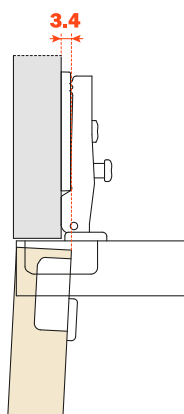

## "C" value

With this formula you can obtain the max. thickness of the moulded door that can be opened without touching adjacent carcass sides, doors or walls, whilst bearing in mind the above L-K-T values.

$$C = 16.5 + K + A$$

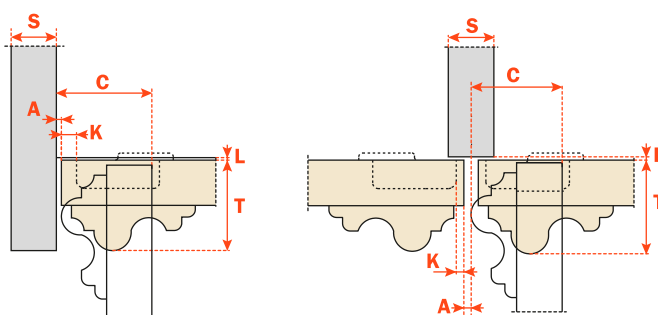

**Packing**

Boxes 600 pcs.  
Pallets 14.400 pcs.

**CA** sprung hinge

Use these formulas to determine the type of hinge arm, the drilling distance "K" and the height of the mounting plate "H" which is necessary to solve each application problem.

Use the tables "Drillings and fixings" at page 159 to complete the code number of the desired hinge.

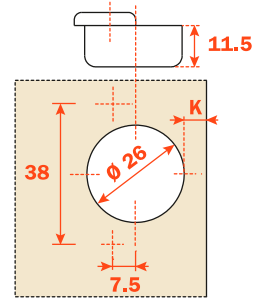
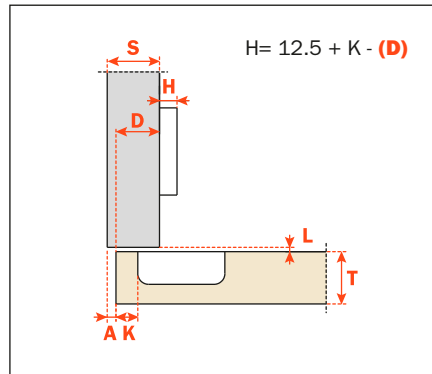
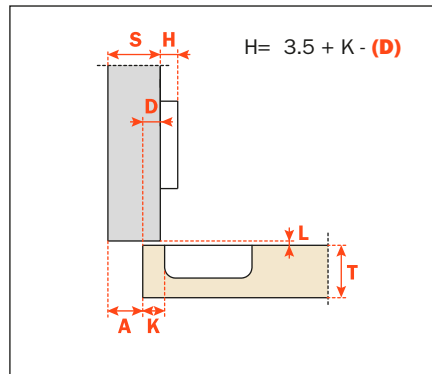
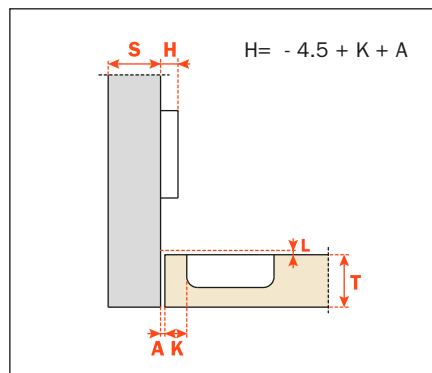
Arm **0****CA - C6\_7C99**Arm **9****CA - C6\_7L99**Arm **17****CA - C6\_7S99**





## Technical information

### For wooden doors with positive angled assembly.

11,5 mm deep metal cup.

94° opening.

Possible drilling distance on the door (K): from 3 to 8 mm.

Compatible with all traditional Series 200 mounting plates.

**NOT COMPATIBLE** with Domi snap-on mounting plates.

### Packing

Boxes 300 pcs.

Pallets 7.200 pcs.

CA sprung hinge

The solution of assembly problems where doors are mounted at a positive or negative angle requires the verification of drilling distances by a practical trial. Please do not hesitate to consult our technical support department for assistance.

Use the tables "Drillings and fixings" at page 159 to complete the code number of the desired hinge.

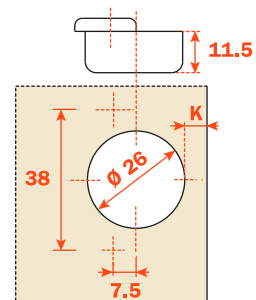

Arm 24°

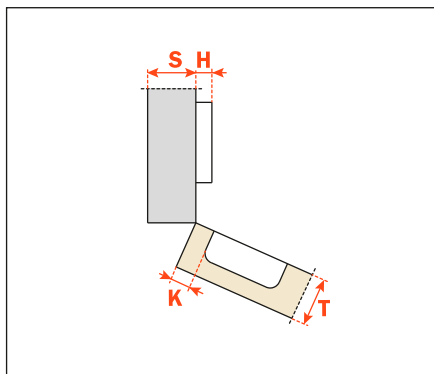

CA - C6\_7U99

Arm 30°

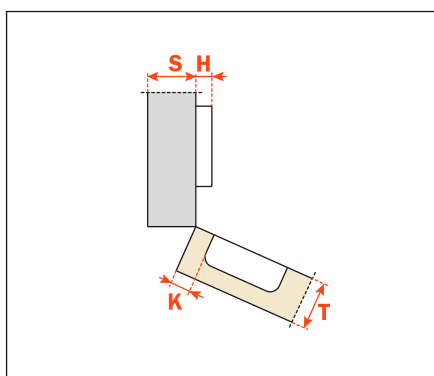

CA - C6\_7E99

Arm 45°

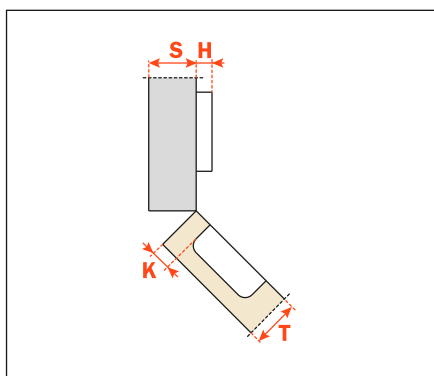

CA - C6\_7M99



### Technical information

#### Crampon hinges.

**For smaller spaces with 15x32 mm drilling.**

11.5 mm deep metal cup.

94° opening.

Possible drilling distance on the door (K): from 3 to 8 mm.

Compatible with all traditional Series 200 mounting plates, 28x32 mm drilling.

**NOT COMPATIBLE** with Domi snap-on mounting plates.

#### Packing

Boxes 300 pcs.

Pallets 7.200 pcs.

Use the tables "Drillings and fixings" at page 159 to complete the code number of the desired hinge.

CA sprung hinge

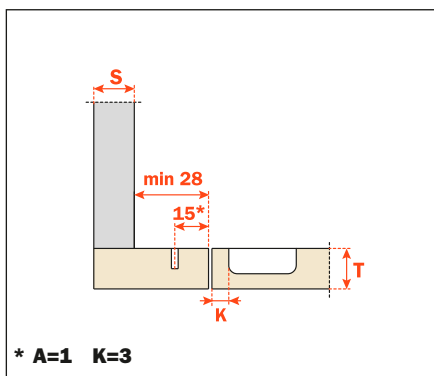
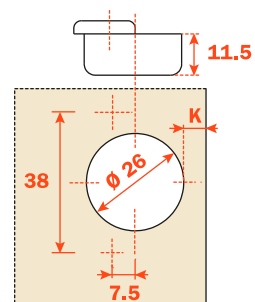

CA - C6\_7N99

Heights of mounting plates for every assembly.

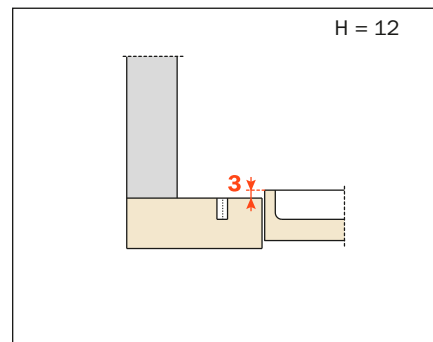
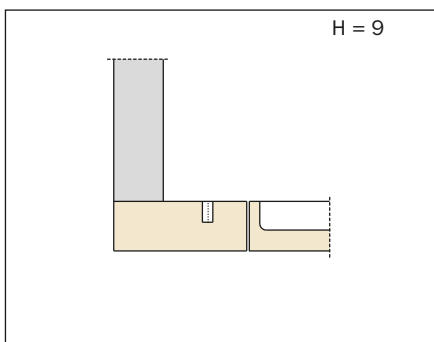
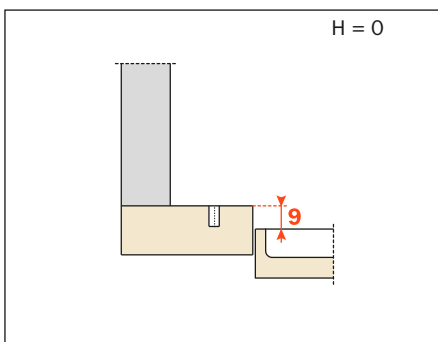



## Technical information

### Hinges for glass doors.

Hole diameter 26 mm.

94° opening.

For use with glass from 4 mm to 6 mm thickness.

Possible drilling distance on the door (K): from 5.5 to 6.5 mm.

Compatible with all traditional Series 200 mounting plates.

**NOT COMPATIBLE** with Domi snap-on mounting plates.

### Packing

Boxes 300 pcs.

Pallets 7.200 pcs.

Use these formulas to determine the type of hinge arm, the drilling distance "K" and the height of the mounting plate "H" which is necessary to solve each application problem.

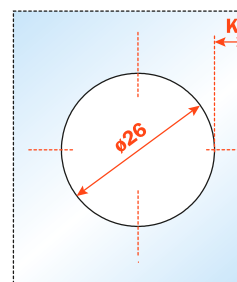

### CA sprung hinge

#### Arm 0

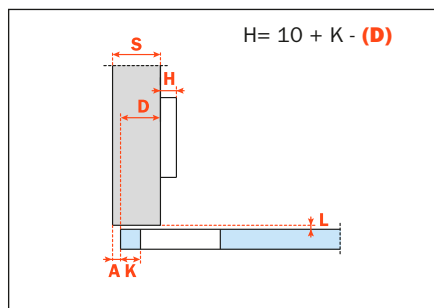

**CA - C6C7C39**

#### Arm 9

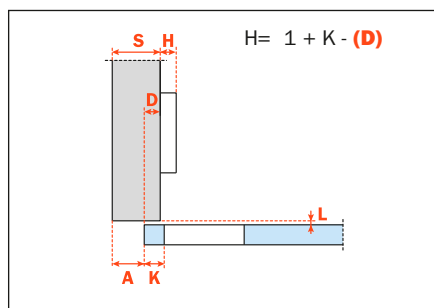

**CA - C6C7L39**

#### Arm 17

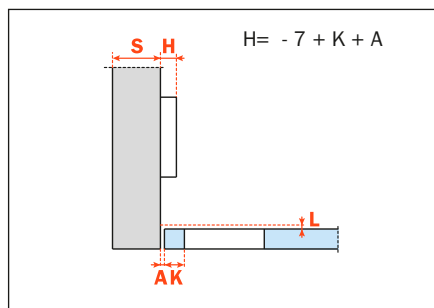

**CA - C6C7S39**



**Technical information**

**Hinges for doors with positive angled assembly and crampon hinges.**

Hole diameter 26 mm.  
 94° opening.  
 For use with glass from 4 mm to 6 mm thickness.  
 Possible drilling distance on the door (K): from 5.5 to 6.5 mm.  
 Compatible with all traditional Series 200 mounting plates.  
**NOT COMPATIBLE** with Domi snap-on mounting plates.

**Packing**

Boxes 300 pcs.  
 Pallets 7.200 pcs.

The solution of assembly problems where doors are mounted at a positive or negative angle requires the verification of drilling distances by a practical trial. Please do not hesitate to consult our technical support department for assistance.

**CA sprung hinge**

Applications with doors set at any angle between -7.5° to +70° are possible by combining the appropriate hinge and mounting plate.

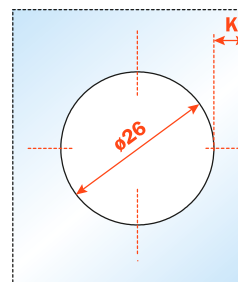

**Arm 30°**

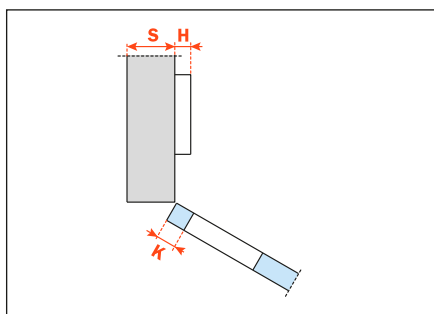

**CA - C6C7E39**

**Arm 45°**

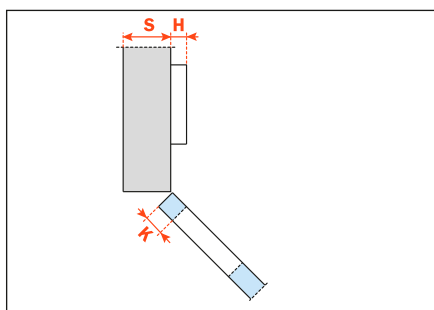

**CA - C6C7M39**

**Crampon**

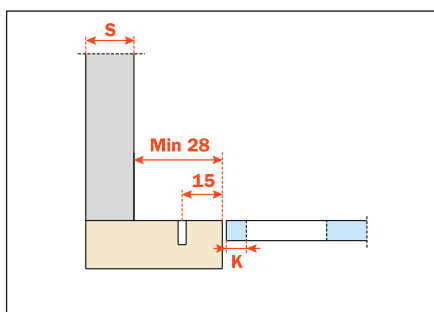

**Crampon hinges.** To be use only with Series 200 mounting plates for traditional assembly and drilling 28x32 mm.

**CA - C6C7N39**

Heights of mounting plates for every assembly.

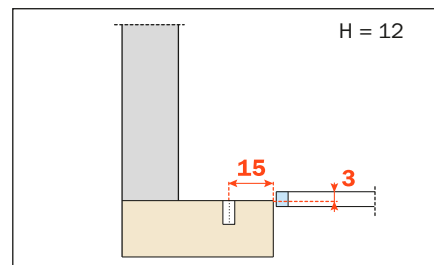
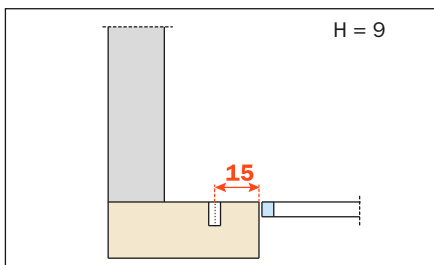
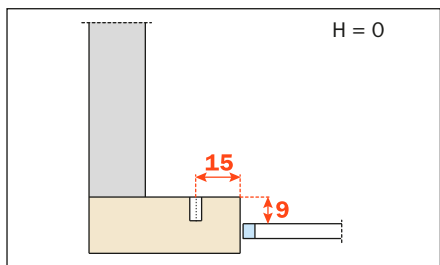



## Series B





**No drilling of the glass is required.**  
**Bright nickel plated die-cast cup and arm.**

### Disclaimer

**Salice Series B (CBG) hinges have been developed for use on glass doors and mirrors. Salice will accept no responsibility for any problems associated with the type of adhesive or method of application when used in conjunction with Series B hinges, nor for any consequences of the incorrect mounting of the door. It is recommended that the selected adhesive is subjected to prior testing. The adhesive may be considered appropriate if the plate, when fixed to the glass, can sustain a minimum torsion load of 160 Nm.**

Constant "L" value of 0.7 mm (it does not change during side adjustment).

Approx. number of hinges required according to the door dimension and weight.

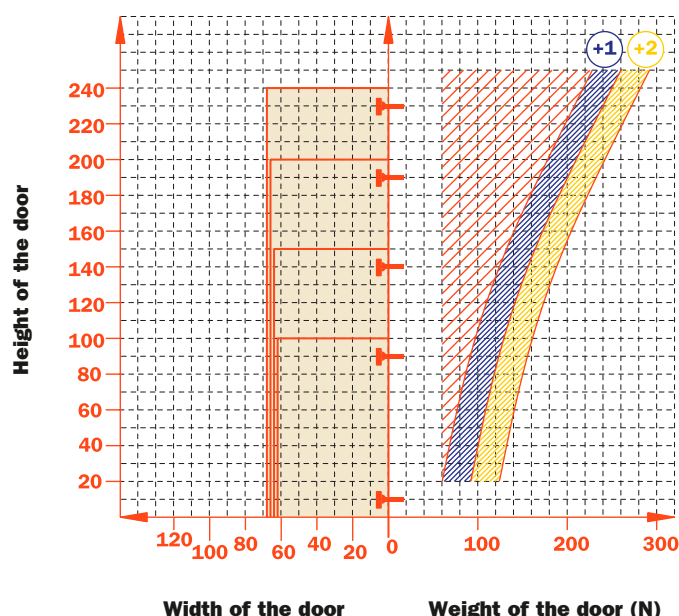

### Adjustments

Compensated side adjustment from -1.5 mm to +4.5 mm.  
 Height adjustment  $\pm 2$  mm.  
 Depth adjustment with Series 200 mounting plates +2.8 mm.  
 Depth adjustment with Domi snap-on mounting plates from -0.5 mm to +2.8 mm.  
 Anti-sliding safety stop.

### Mounting plates

Symmetrical and asymmetrical bright nickel plated steel or die-cast Series 200 mounting plates.  
 Snap-on assembly on Domi mounting plates.  
 Positioning with pre-determined stop on traditional Series 200 mounting plates.

N.B. : Use POZIDRIVE No. 2 screwdrivers for all screws.

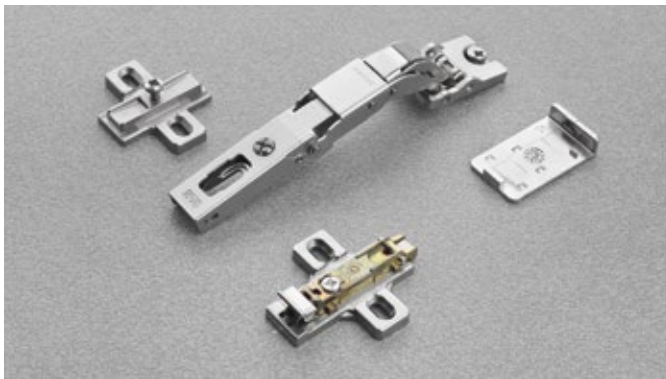

**Technical information**

**Hinge for glass doors. No drilling of the glass is required.**  
Possible fixing inset distance on the door (K): from 0 to 22 mm.  
110° opening.  
Compatible with all traditional Series 200 mounting plates and with all Domi snap-on mounting plates.

CA sprung hinge

**Packing**

Boxes 150 pcs.  
Pallets 3.600 pcs.

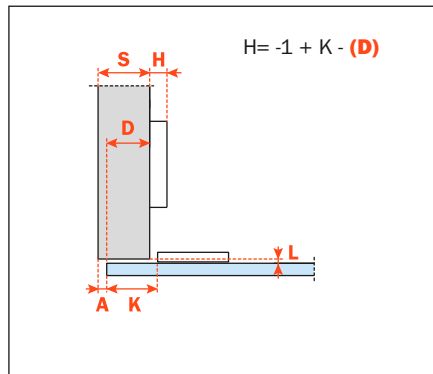
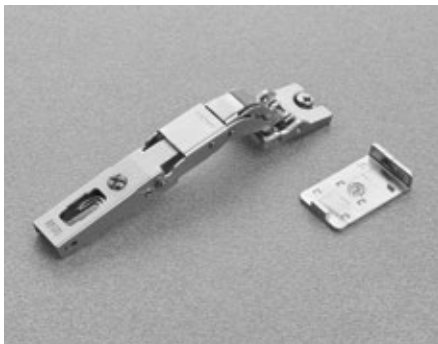

**CA - CBG2A99**

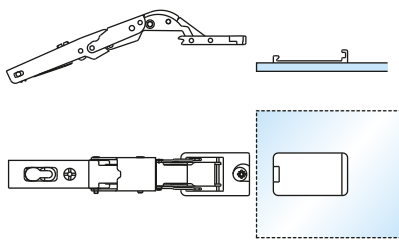

**1)** The hinge plate must be attached to the glass door or mirror by a special adhesive. We recommend that this operation is carried out by a specialist company. For further information on adhesives and their application, please contact the adhesive manufacturer or your glass supplier.

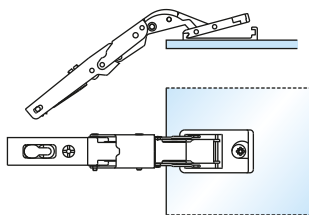

**2)** Fix the hinge when the plate is bonded to the glass.

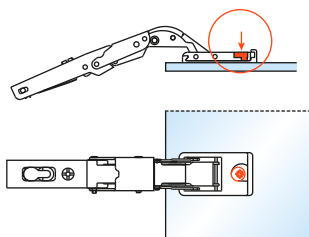

**3)** Locate the hinge cup onto the plate and rotate the cam.

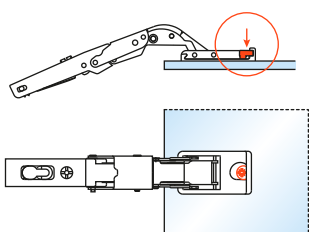

**4)** The hinge is now fixed to the door.

**“C” value**

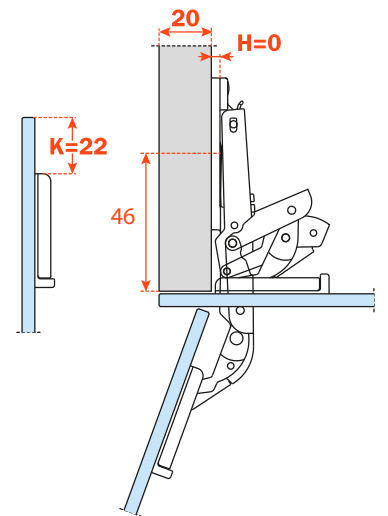

**K = 0 - 22**

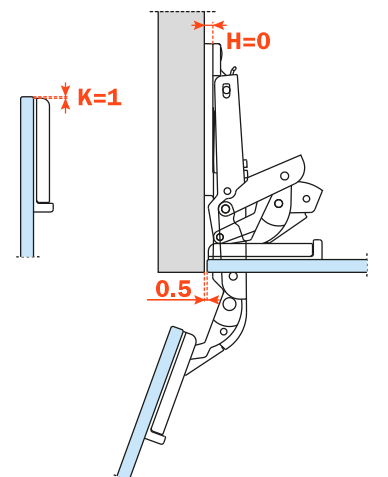

Series B hinges provide a solution to a number of applications that feature moulded edge profiles or half-inlay doors.

Dimensions of the  $\varnothing 35$  mm cup.

Bright nickel plated die-cast cup and arm.

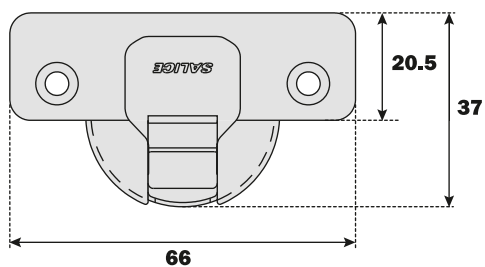

Constant "L" value of 0.7 mm (it does not change during side adjustment).

Approx. number of hinges required according to the door dimension and weight.

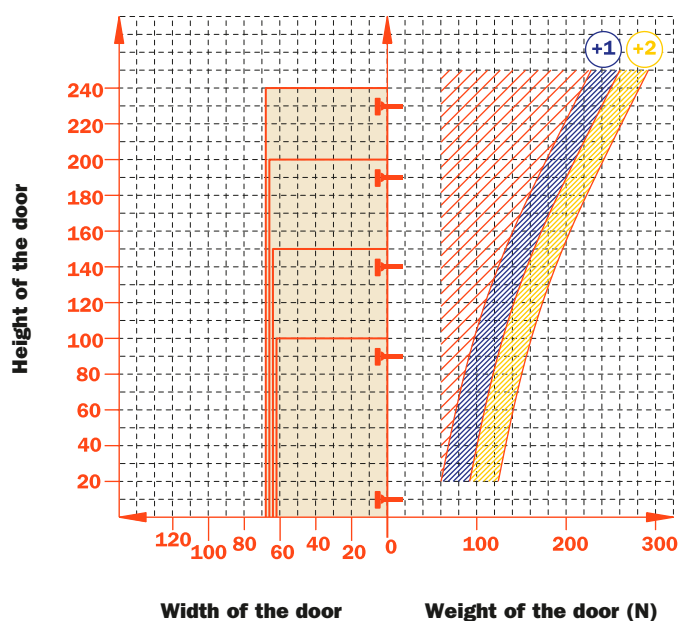

## Adjustments

Compensated side adjustment from -1.5 mm to +4.5 mm.  
 Height adjustment  $\pm 2$  mm.  
 Depth adjustment with Series 200 mounting plates +2.8 mm.  
 Depth adjustment with Domi snap-on mounting plates from -0.5 mm to +2.8 mm.  
 Anti-sliding safety stop.

## Mounting plates

Symmetrical and asymmetrical bright nickel plated steel or die-cast Series 200 mounting plates.  
 Snap-on assembly on Domi mounting plates.  
 Positioning with pre-determined stop on traditional Series 200 mounting plates.

N.B. : Use POZIDRIVE No. 2 screwdrivers for all screws.

	<p>48  <math>\varnothing 35</math>          6  <b>110°</b></p>	<p>45  <math>\varnothing 35</math>          9.5  <b>110°</b></p>	<p>52  <math>\varnothing 35</math>          5.5  <b>110°</b></p>
<b>Wood screw</b> 	<b>A</b>	<b>P</b>	<b>U</b>
	<p>48  <math>\varnothing 35</math>  <math>\varnothing 10</math>          6  <b>110°</b></p>	<p>45  <math>\varnothing 35</math>  <math>\varnothing 8</math>          9.5  <b>110°</b></p>	<p>52  <math>\varnothing 35</math>  <math>\varnothing 10</math>          5.5  <b>110°</b></p>
<b>Dowel</b> 	<b>B</b>	<b>R</b>	<b>W</b>

Use this table to identify the available drillings and fixings.

Fill the third position of the hinge code number with the letter or the number corresponding to your choice. I.e.: CB\_2A99.



Fill this position with the chosen letter or number.



## Technical information

**Series B hinges provide a solution to a number of applications that feature moulded edge profiles or half-inlay doors.**

9 mm deep metal cup.  
 110° opening.  
 Possible drilling distance on the door (K): from 3 to 18 mm.  
 Compatible with all traditional Series 200 mounting plates and with all Domi snap-on mounting plates.

## Space needed to open the door

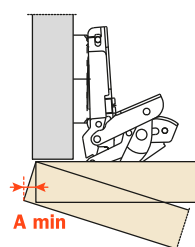

	T=	16	18	20	22	24	26
K=3	<b>A=</b>	0.0	0.0	0.0	0.0	0.3	1.4
K=4	<b>A=</b>	0.0	0.0	0.0	0.0	0.4	1.5
K=5	<b>A=</b>	0.0	0.0	0.0	0.0	0.5	1.9
K=6	<b>A=</b>	0.0	0.0	0.0	0.0	0.7	2.6
K=7	<b>A=</b>	0.0	0.0	0.0	0.0	11.3	12.8
K=8	<b>A=</b>	0.0	0.0	0.0	0.0	10.3	12.9
K=9	<b>A=</b>	0.0	0.0	0.0	0.0	9.3	11.9
K=10	<b>A=</b>	0.0	0.0	0.0	6.0	8.3	10.9
K=11	<b>A=</b>	0.0	0.0	0.0	5.1	7.3	9.9
K=12	<b>A=</b>	0.0	0.0	0.0	4.1	6.3	8.9
K=13	<b>A=</b>	0.0	0.0	1.4	3.3	5.3	7.9
K=14	<b>A=</b>	0.0	0.0	0.7	2.6	4.5	6.9
K=15	<b>A=</b>	0.0	0.0	0.2	2.0	3.8	5.9
K=16	<b>A=</b>	0.0	0.0	0.0	1.4	3.2	5.0
K=17	<b>A=</b>	0.0	0.0	0.0	1.0	2.7	4.4
K=18	<b>A=</b>	0.0	0.0	0.0	0.7	2.2	3.9

**The above values are calculated on the assumption that the doors have square edges. They are reduced if the doors have radiussed edges.**

## Projection of the door

Projection of the door from the cabinet side at the max. opening. The figures are based on a straight arm hinge, H=0 mm thickness of mounting plate and K value = 3 mm.

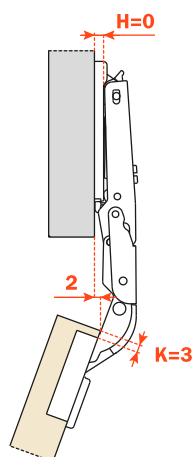

## “C” value

With this formula you can obtain the max. thickness of the moulded door that can be opened without touching adjacent carcase sides, doors or walls, whilst bearing in mind the above L-K-T values.

$$C = 5.5 + K + A$$

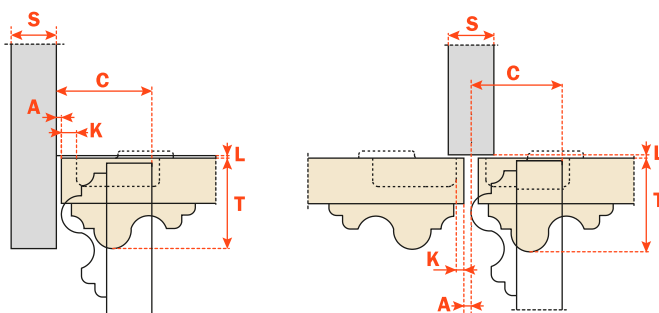

**Packing**

Boxes 150 pcs.  
Pallets 3.600 pcs.

**CA** sprung hinge

Use these formulas to determine the type of hinge arm, the drilling distance "K" and the height of the mounting plate "H" which is necessary to solve each application problem.

To limit the opening of the hinge, see page 361 chapter "Accessories".

Use the tables "Drillings and fixings" at page 171 to complete the code number of the desired hinge.

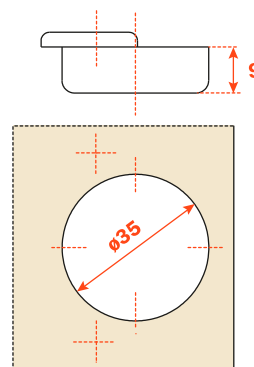

## Arm 0

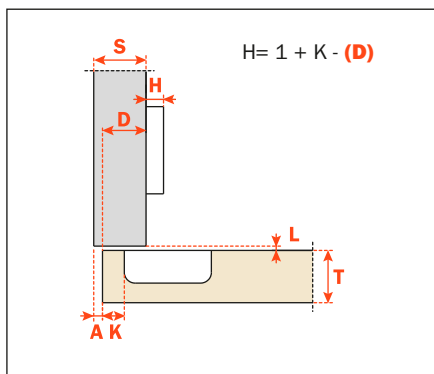
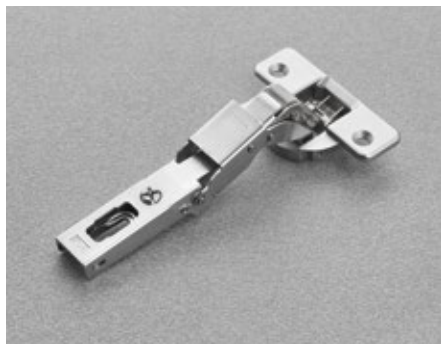
**CA - CB\_2A99**



**Series B - For wooden doors - assembly examples**

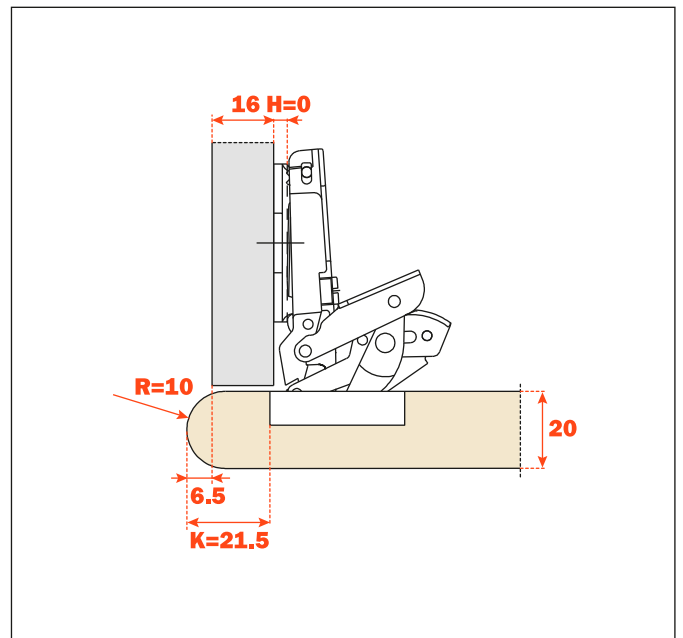
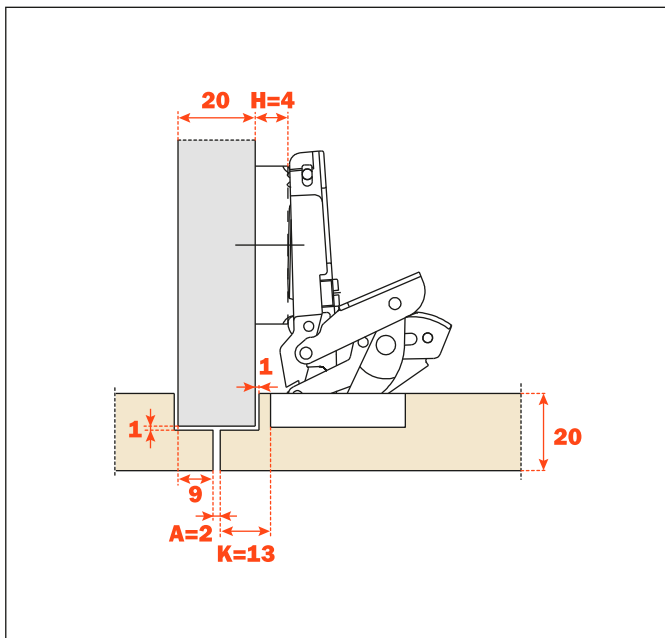
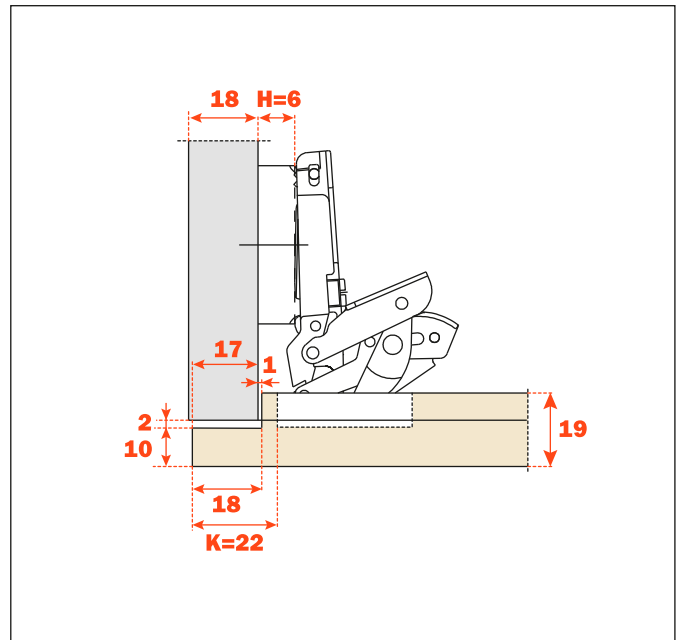
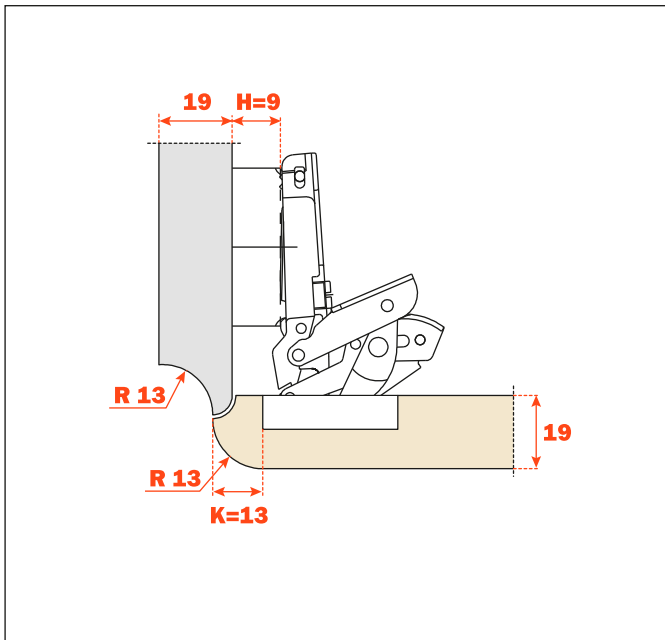
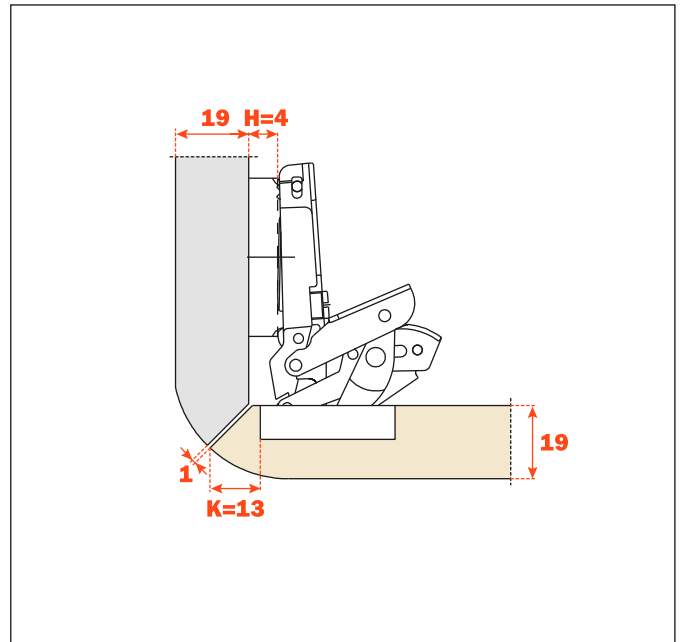
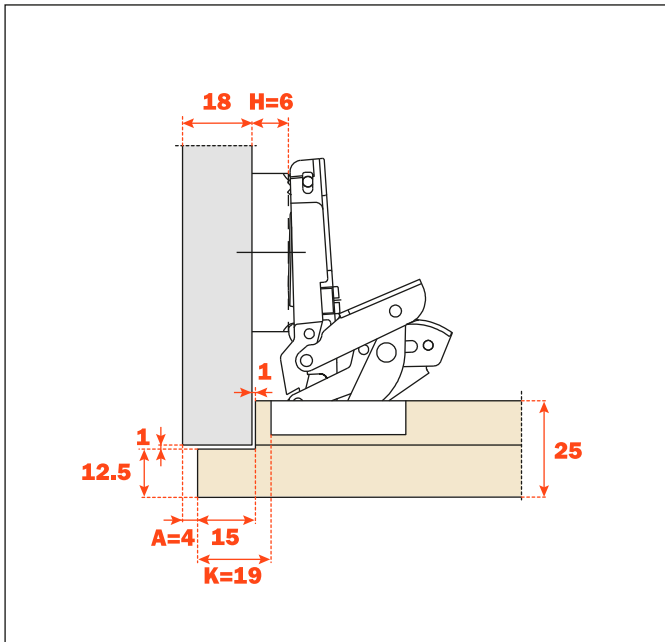

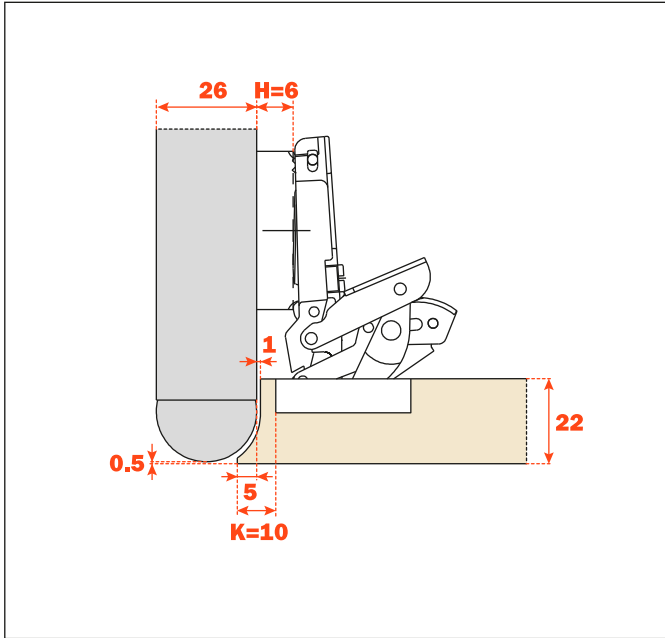
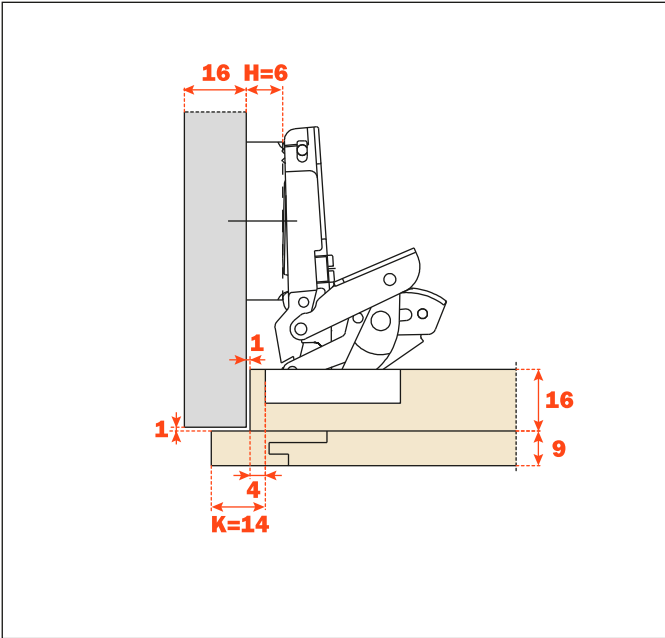
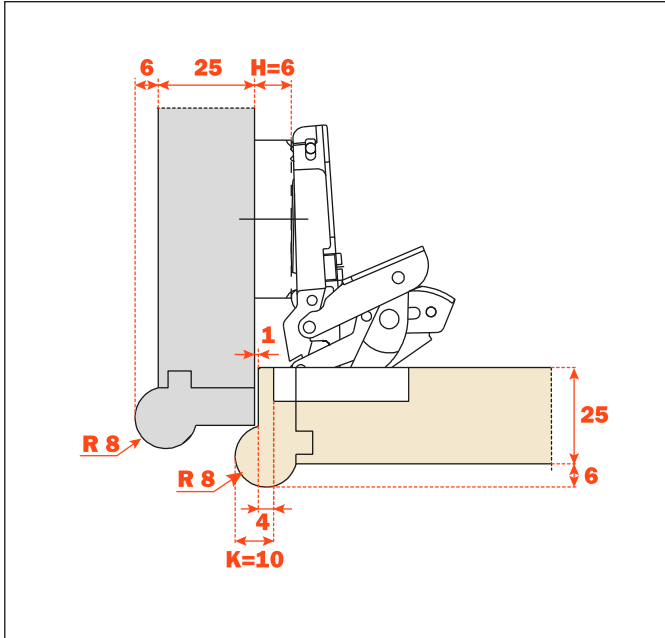
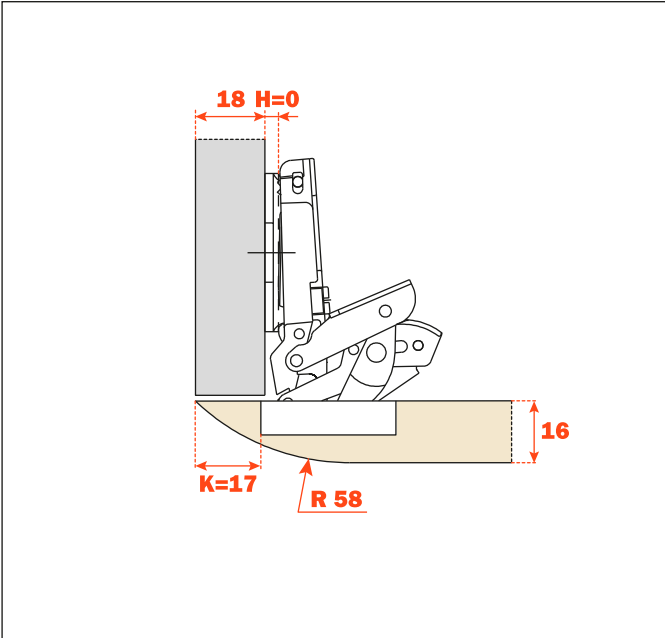
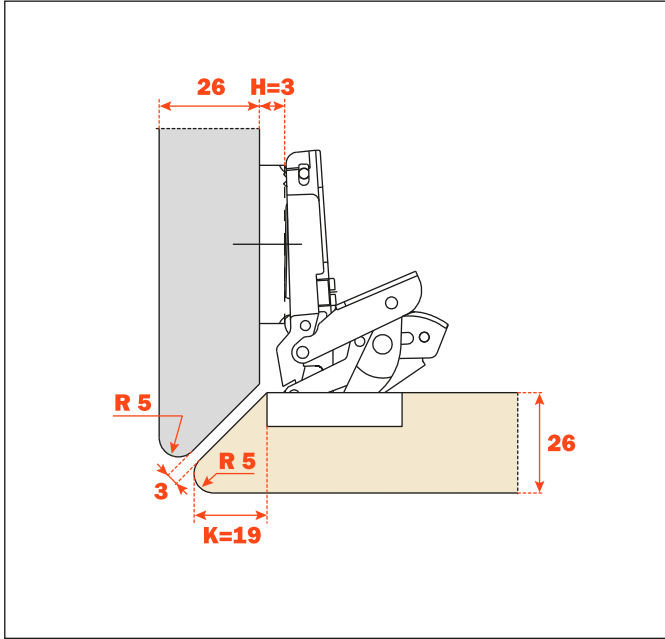
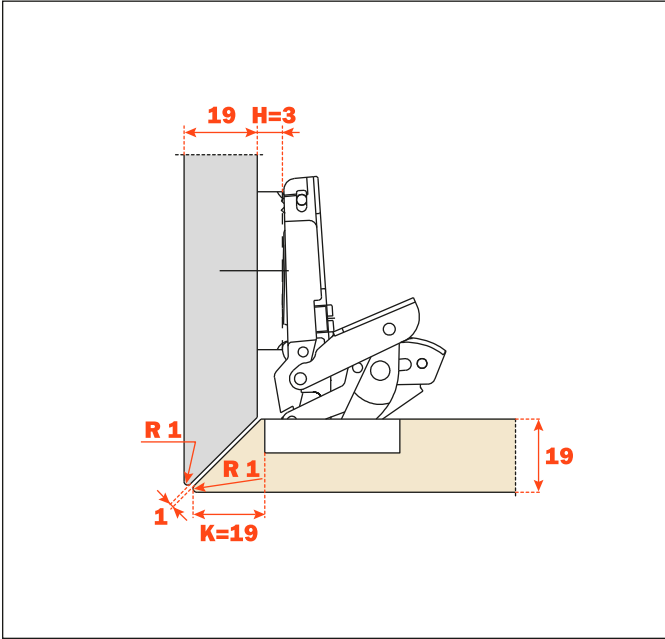



## Series M

Series M



Bright nickel plated die-cast cup and arm.  
Sprung hinge (with spring).

Ideal for the most critical applications, where high stability, strength and endurance are required. They are certified for applications in public environments in conformity with FIRA Level 5 and ANSI Grade 1 requirements.

**Adjustments**

Compensating side adjustment from -3 mm to +3 mm.  
With mounting plates H=0 the negative side adjustment cannot be used.  
Height adjustment ±2 mm.  
Depth adjustment with Series 200 mounting plates +2.8 mm.  
Depth adjustment with Domi snap-on mounting plates from -0,5 mm to +2.8 mm.  
Anti-sliding safety stop.

**Mounting plates**

Symmetrical and asymmetrical bright nickel plated steel or die-cast Series 200 mounting plates.  
Snap-on assembly on Domi mounting plates.  
Positioning with pre-determined stop on traditional Series 200 mounting plates.  
N.B. : Use POZIDRIVE No. 2 screwdrivers for all screws.

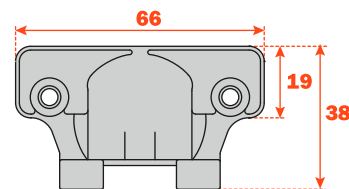

**Drillings and fixings**

Wood screw	A	P	U
Dowel	B	R	W

Use this table to identify the available drillings and fixings. Fill the third position of the hinge code number with the letter or the number corresponding to your choice. I.e.: CM\_3A99.

↑  
Fill this position with the chosen letter or number.

# CM\_3A99



Use the tables "Drillings and fixings" at page 178 to complete the code number of the desired hinge.

**Packing**  
Boxes 100 pcs.  
Pallets 2.400 pcs.

Use these formulas to determine the height of the mounting plate "H" which is necessary to solve each application problem.

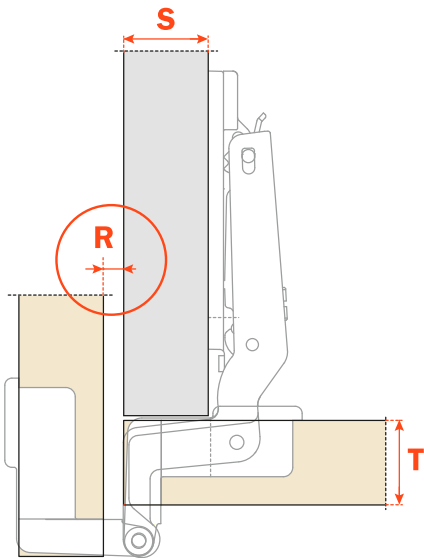
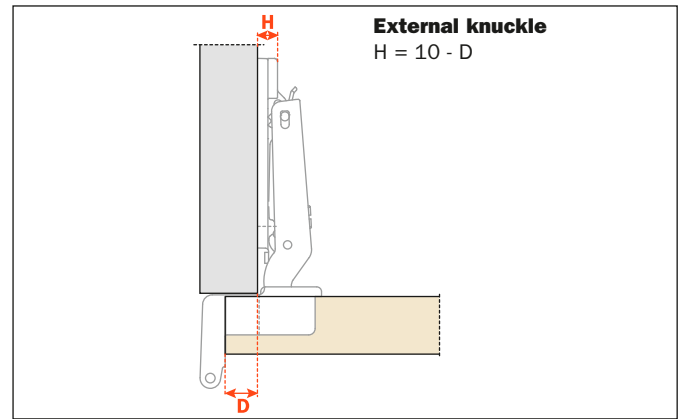
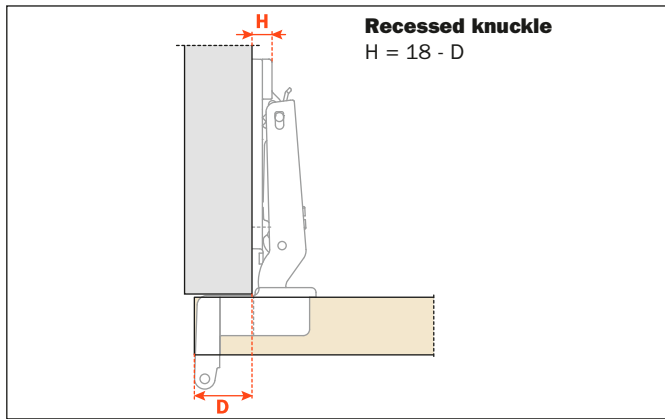

**Chart to verify that full 270° opening is possible.**  
Full 270° opening is possible only with R value ≥ 0 and mounting plates H=0 mm.  
Otherwise the actual opening must be checked with a practical test.

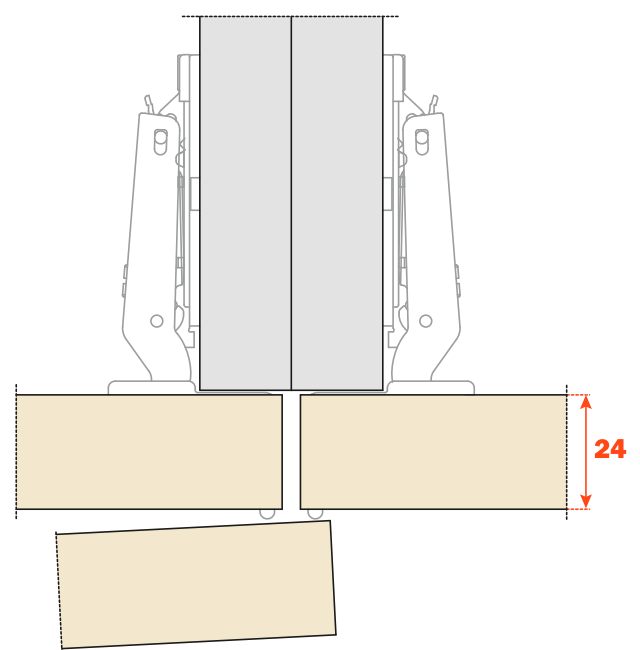

**180° opening with door thickness max. 24 mm.**

		Door thickness T		
		18	19	20
Side thickness S	20	2,25	1,25	0,25
	19	3,25	2,25	1,25
	18	4,25	3,25	2,25
R value				



**Application with recessed knuckle**

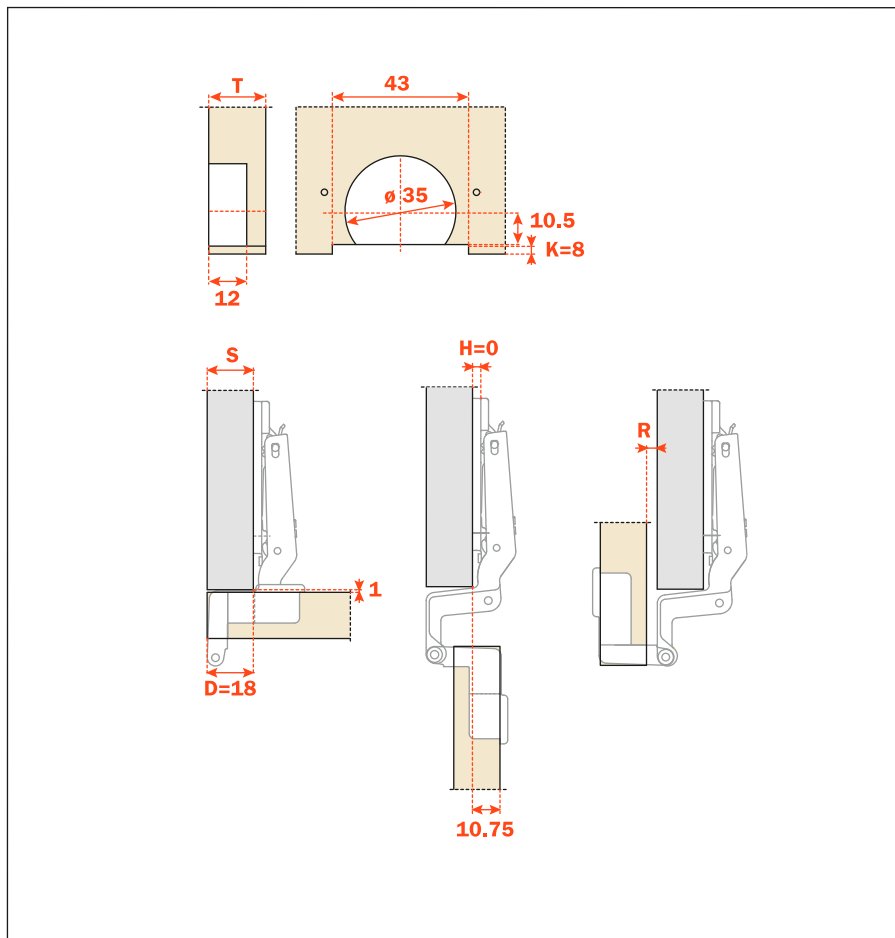

**Application with external knuckle**

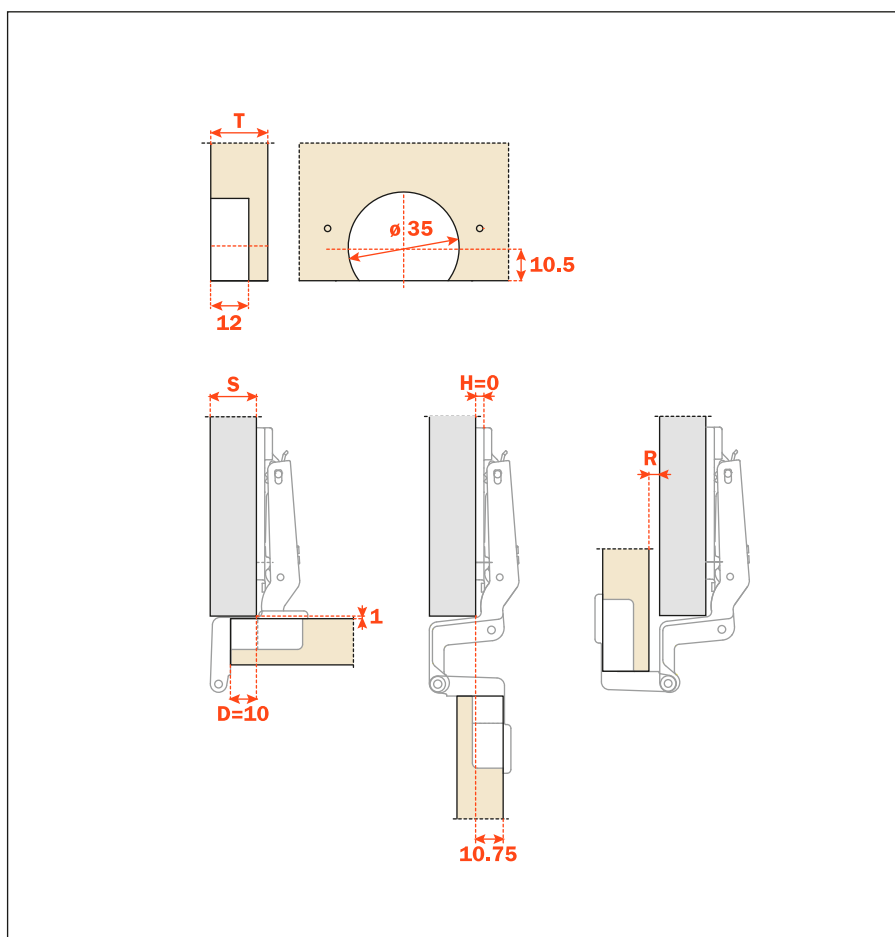

### Application with inset door

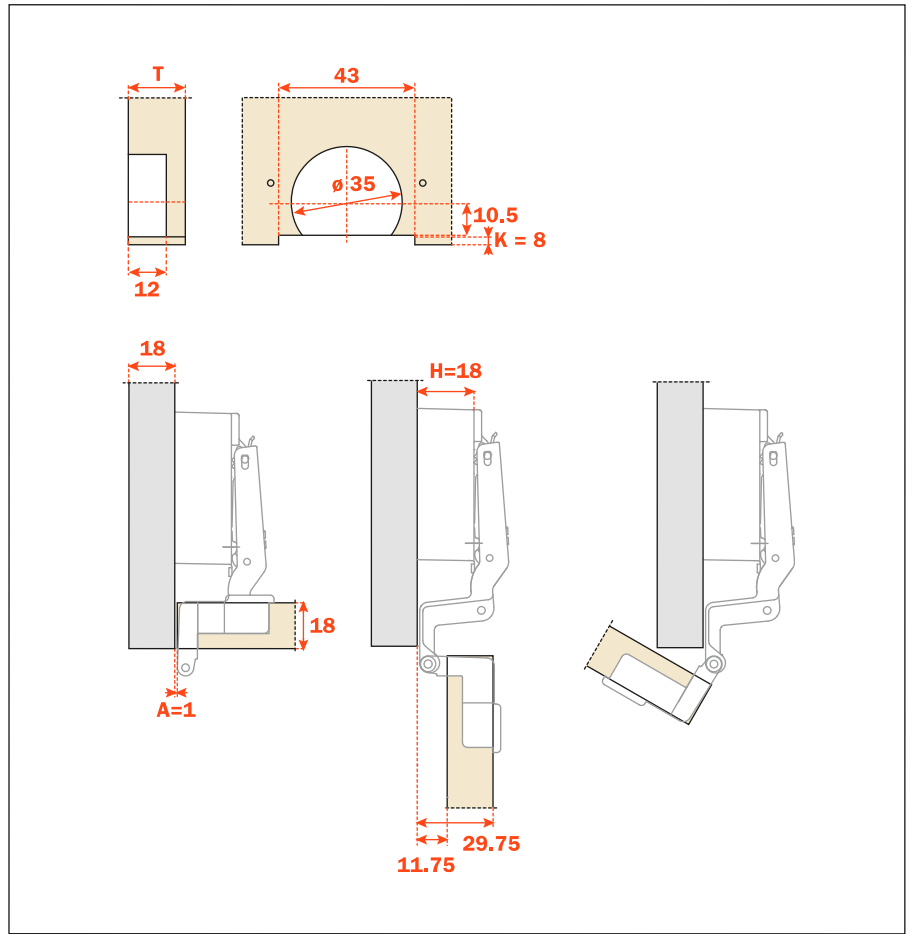

### Application with half overlay door

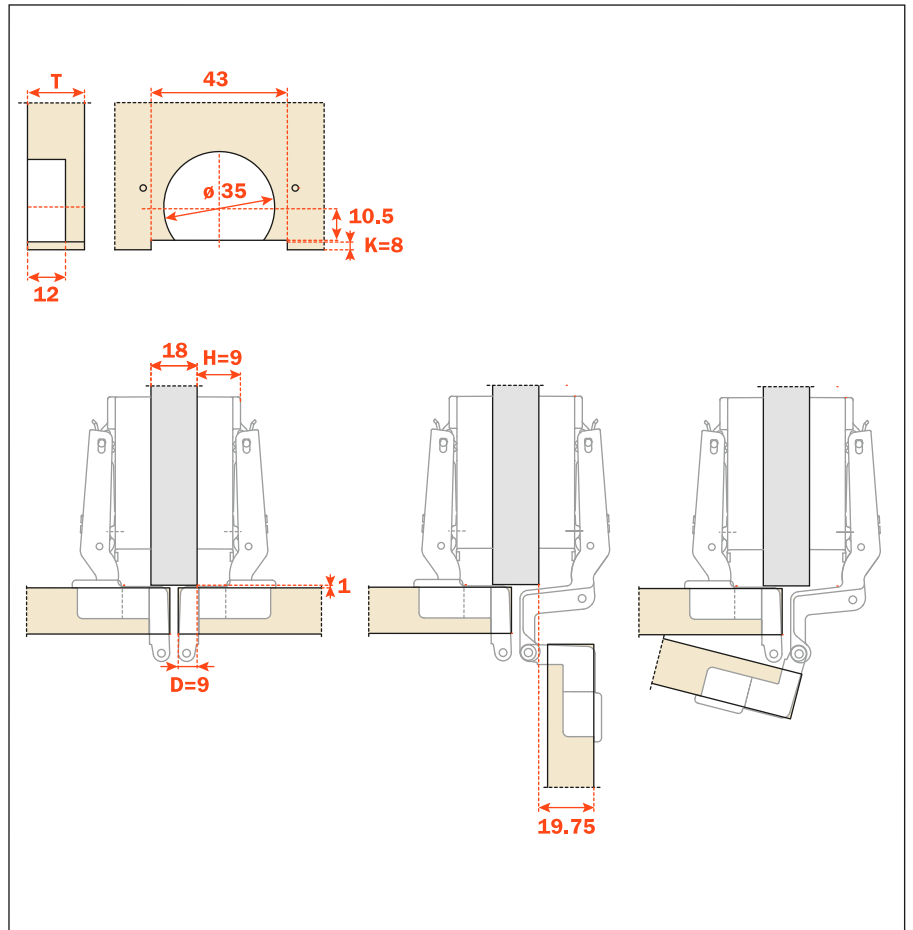



# Mechanical Push



Mechanical Push

## Mechanical Push

The PUSH-System is a self-opening system for the doors of all types of handleless furniture.

It consists of a series of self-opening hinges, release devices that can be fitted to the top, base or side panel of the cabinet, and retaining catches to be fitted to the back of the door.

The retaining catches can be pressure-fixed or screw-fixed.

For doors over 1600 mm in height, we suggest that you use two mechanical release catches.



**DP1SNB** - beige



**DP1SNG** - grey



With assembly stop device

**Packing**  
Boxes 300 pcs.

### Installation of mechanical Push with adhesive strip

For correct application and to ensure optimal endurance, please follow the following procedure:

- 1)** clean and degrease the cabinet surface where the release device is to be installed using an acetone based cleaner;
- 2)** remove the protective strip from the adhesive;
- 3)** place the release device in position and apply a firm pressure for about one minute;
- 4)** allow a period of 12 hours to elapse before subjecting the PUSH-System to continuous usage.





## Mechanical Push - Release device to be screw-fixed

**DP3SNB** - beige



**DP3SNG** - grey



With assembly stop device

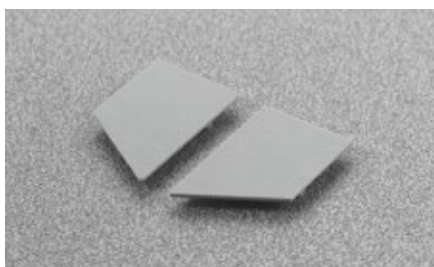
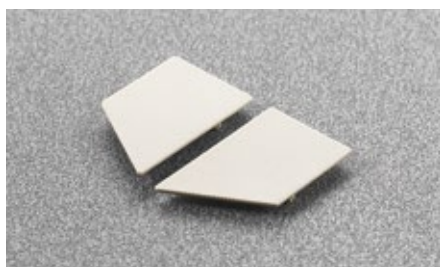

**Packing**  
Boxes 300 pcs.

**DP3SNBR** - beige



**DP3SNGR** - grey



Without assembly stop device

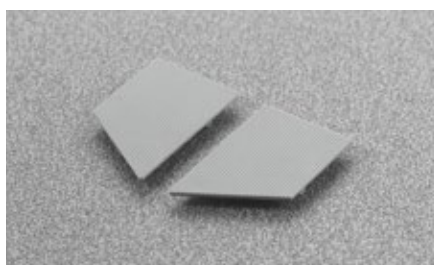
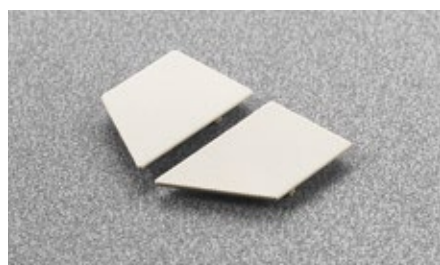

**Packing**  
Boxes 300 pcs.



**DP4SNB** - beige



**DP4SNG** - grey

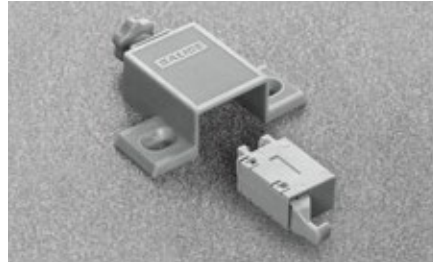

Single adapter with depth and sideways adjustment and release device. Without assembly stop device.

**Packing**

Boxes 300 pcs.

**DP5SNB** - beige



**DP5SNG** - grey

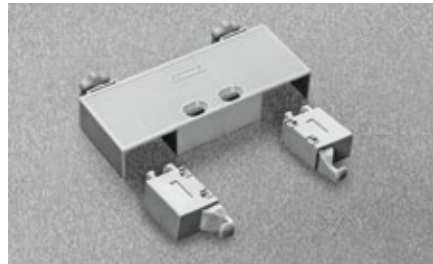

Double adapter with depth and sideways adjustment and release devices. Without assembly stop device.

**Packing**

Boxes 150 pcs.

**N.B.: Drilling patterns at page 192**

**Technical information on the adjustable mechanical Push**

The adjustable Push consists of a release device and a screw-fixed adapter which have been developed to improve the locating action of the system.

The adjustable Push now has a depth adjustment facility with a range of -1 mm to + 2.5 mm which is controlled by a small adjuster wheel located at the back of the adapter.

In addition, the adapter has a sideways adjustment facility of  $\pm 2$  mm. This is achieved by loosening the two fixing screws and adjusting the position of the adapter using the elongated holes. Finally, the screws must be retightened.



## Mechanical Push - Retaining catches for wooden doors

**DP29SNB** - beige



**DP29SNG** - grey



Retaining catch for wooden door.  
Knock-in.

**Packing**  
Boxes 300 pcs.

**DP29SNBMC** - beige



**DP29SNGMC** - grey



Retaining catch for wooden door and special  
assemblies.  
Knock-in.

**Packing**  
Boxes 300 pcs.

**DP29SNBI** - beige



**DP29SNGI** - grey

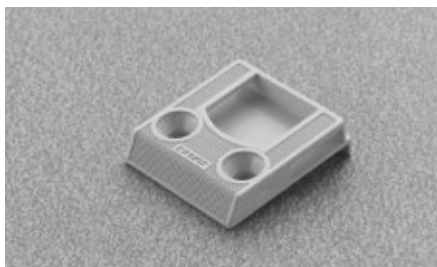

Retaining catch for wooden door.  
With assembly stop device.  
Screw-on.

**Packing**  
Boxes 300 pcs.

**DP29SNBR** - beige



**DP29SNGR** - grey

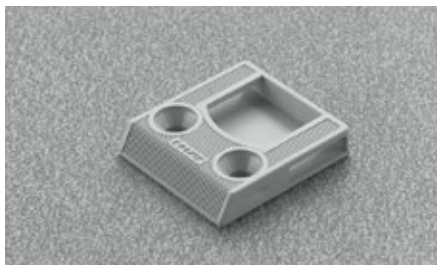

Retaining catch for wooden door.  
Without assembly stop device.  
Screw-on.

**Packing**  
Boxes 300 pcs.

**N.B.: Drilling patterns at page 193**

**DP29SNBA** - beige



**DP29SNGA** - grey



Retaining catch for aluminium-frame door  
width = 35 - 45 mm.

**Packing**  
Boxes 300 pcs.

**DP29SNBB** - beige



**DP29SNGB** grey



Retaining catch for aluminium-frame door  
width = 17 - 35 mm.

**Packing**  
Boxes 300 pcs.

**DP29SNBP** - beige



**DP29SNGP** - grey



Retaining catch for aluminium-frame door  
Practical.

**Packing**  
Boxes 300 pcs.

**N.B.:** Drilling patterns at pages 194 and 195

**DP52SNB** - beige



**DP52SNG** - grey

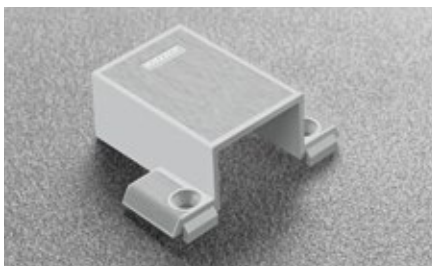

Single adapter.  
6x40 mm drilling.  
With assembly stop device.  
**DP53SN\_** = single adapter with sideways adjustment.

**Packing**  
Boxes 300 pcs.

**DP52SNBR** - beige



**DP52SNGR** - grey

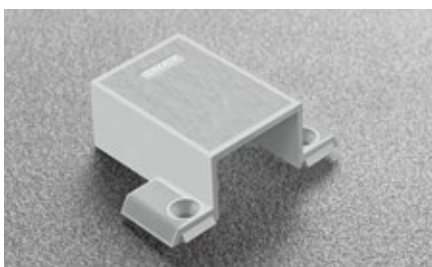

Single adapter.  
6x40 mm drilling.  
Without assembly stop device.  
**DP53SN\_R** = single adapter with sideways adjustment.

**Packing**  
Boxes 300 pcs.

**DP54SNB** - beige



**DP54SNG** - grey

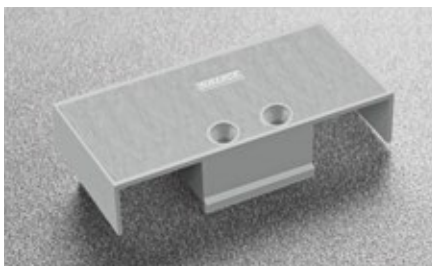

Double adapter.  
6x16 mm drilling.  
With assembly stop device.

**Packing**  
Boxes 150 pcs.

**DP54SNBR** - beige



**DP54SNGR** - grey

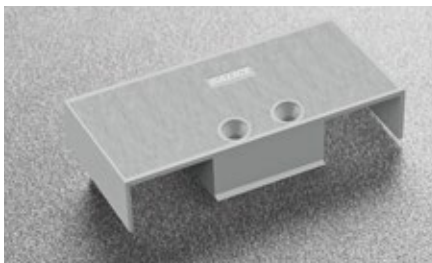

Double adapter.  
6x16 mm drilling.  
Without assembly stop device.

**Packing**  
Boxes 150 pcs.



**DP44XXBD** - beige



**DP44XXGD** - grey

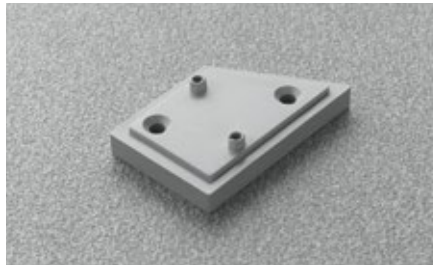

Right spacer H = 4.8 mm.

**Packing**  
Boxes 300 pcs.

**DP44XXBS** - beige



**DP44XXGS** - grey

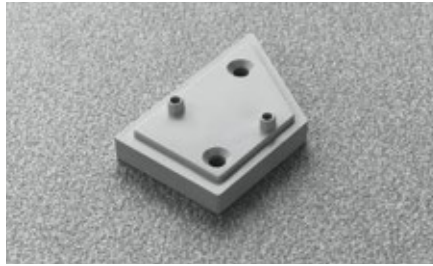

Left spacer H = 4.8 mm.

**Packing**  
Boxes 300 pcs.

**DP50SN0**



Orange insertion tool for retaining catch DP29SN\_.



## Push with depth and sideways adjustment

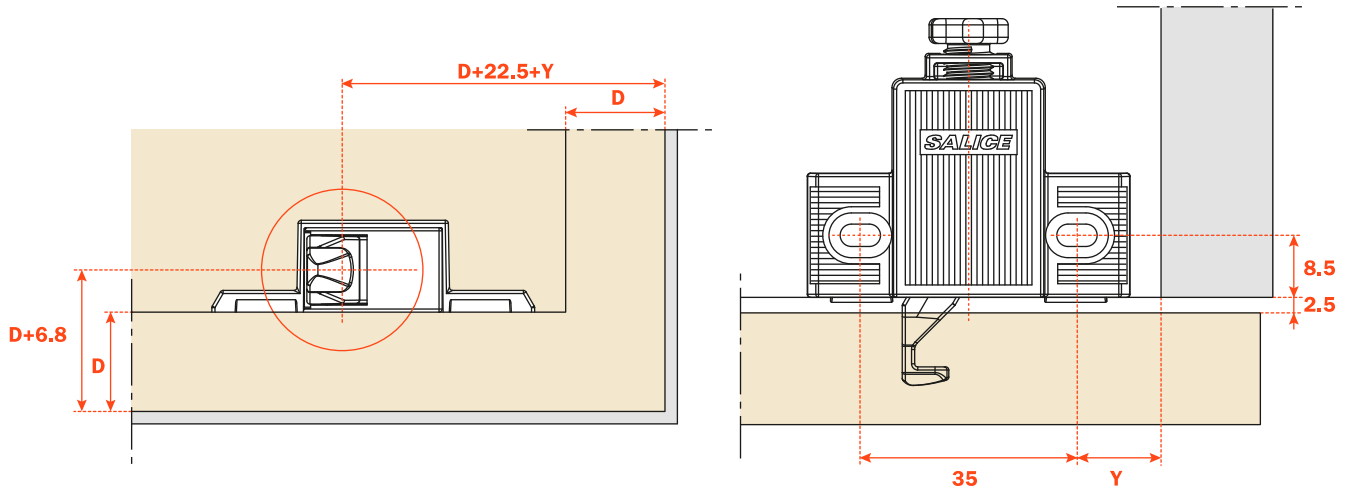

**D** = Door overlay on side and top of the cabinet  
**Y** = min. 8.5 mm

## Double Push with depth and sideways adjustment

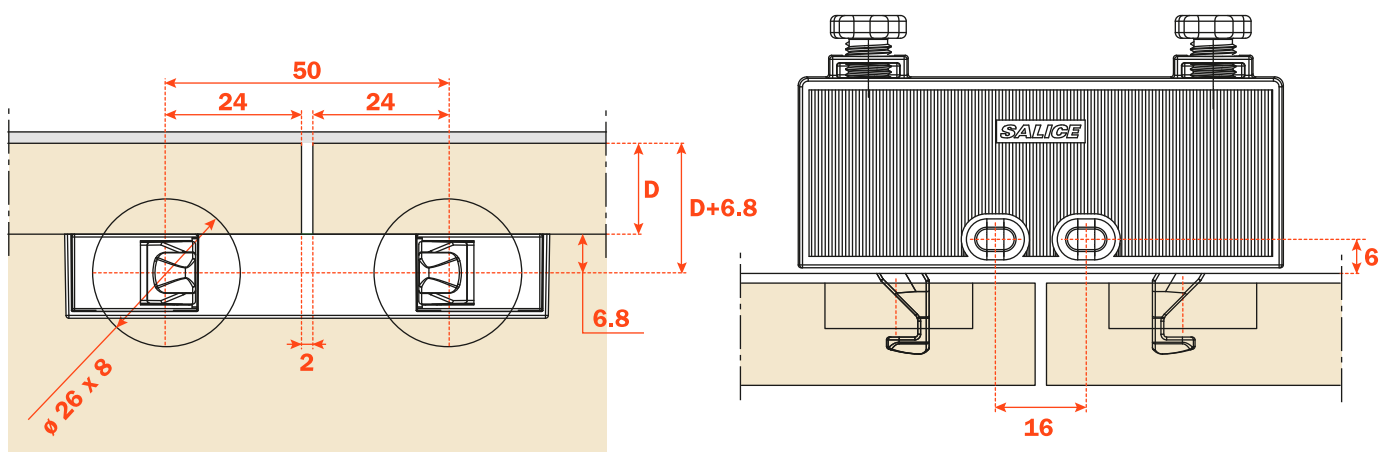

**Fulloverlay door**

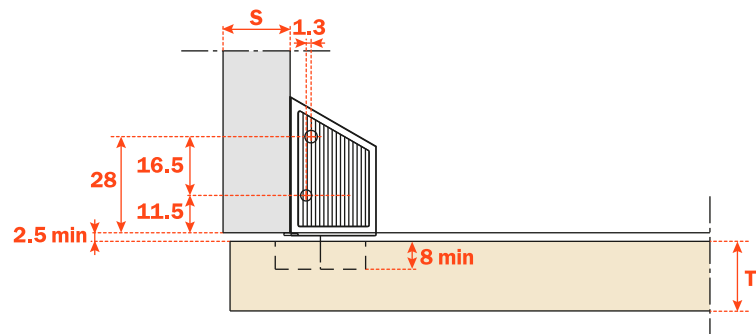
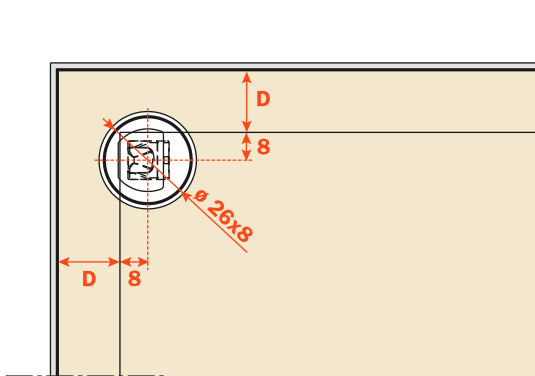

**D = Door overlay on side and top of the cabinet**  
**Drilling distance of retaining catch = D + 8**

**Special assemblies**

$$\begin{aligned} A &= X - D + 4.5 \\ P &= X - D + 10.8 \\ X \text{ min} &= D + 8 \end{aligned}$$

$$\begin{aligned} A &= 26 - 18 + 4.5 = 12.5 \\ P &= 26 - 18 + 10.8 = 18.8 \\ X \text{ min} &= 18 + 8 = 26 \end{aligned}$$

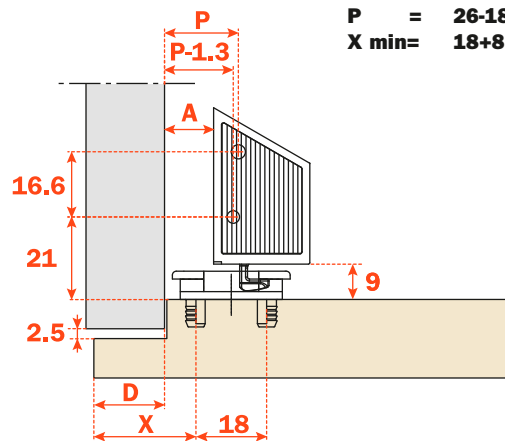
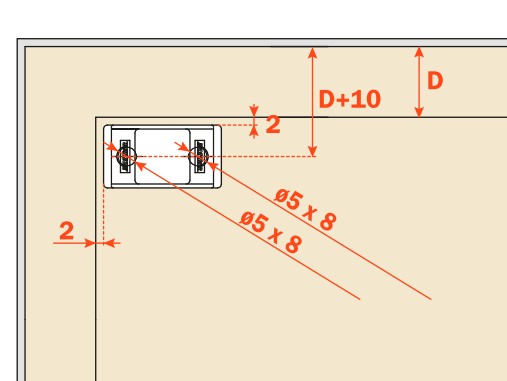

**D = Door overlay on side and top of the cabinet**

**Inset door**

$$\begin{aligned} P &= 14.8 + A \\ P1 &= 36.8 + T \\ P2 &= P - 1.3 \\ P3 &= P1 - 16.5 \end{aligned}$$

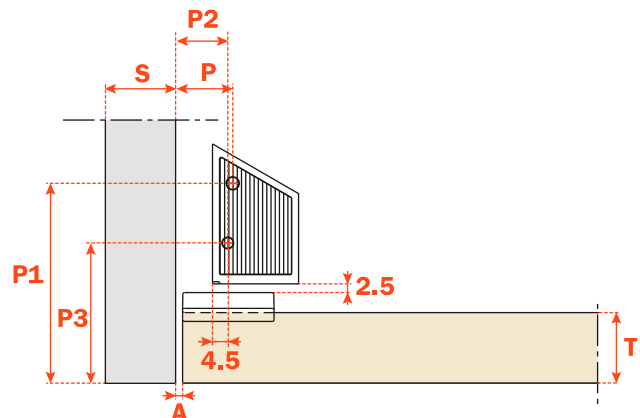
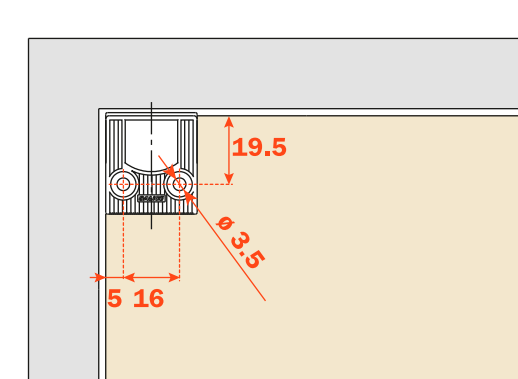



# Mechanical Push - Drilling for aluminium frame doors

## Profile min. 17 mm/max 35 mm

- D** = Door overlay on side and top of the cabinet
- F** = Drilling distance of retaining catch =  $D + 8$
- X** = Relative to the distance to the corner of the profile
- P** = Fixing distance of PUSH =  $X - D + 1.3$

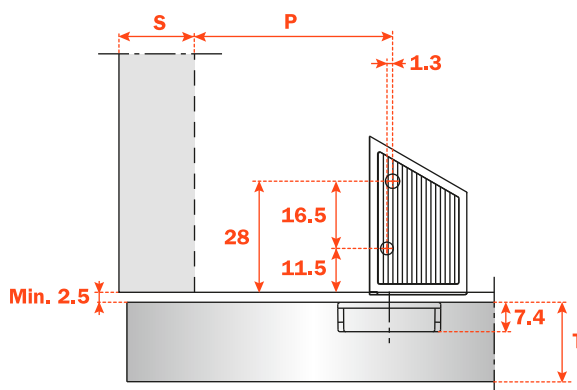
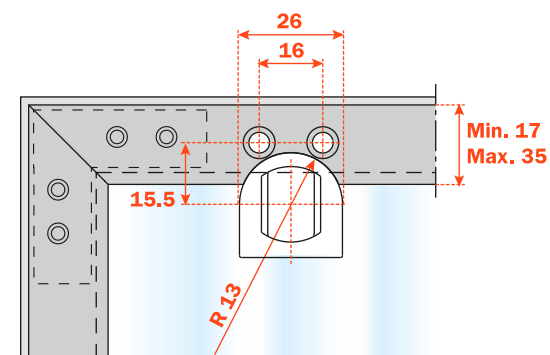
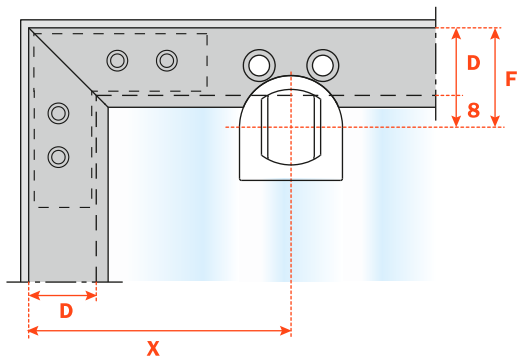

## Profile min. 35 mm/max. 45 mm

- D** = Door overlay on side and top of the cabinet
- F** = Drilling distance of retaining catch =  $D + 8$
- X** = Relative to the distance to the corner of the profile
- P** = Fixing distance of PUSH =  $X - D + 1.3$

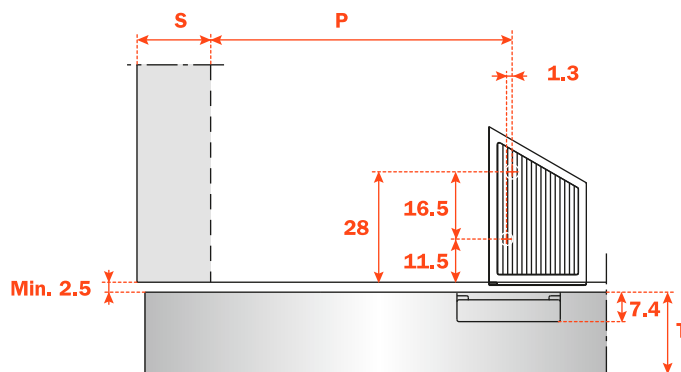
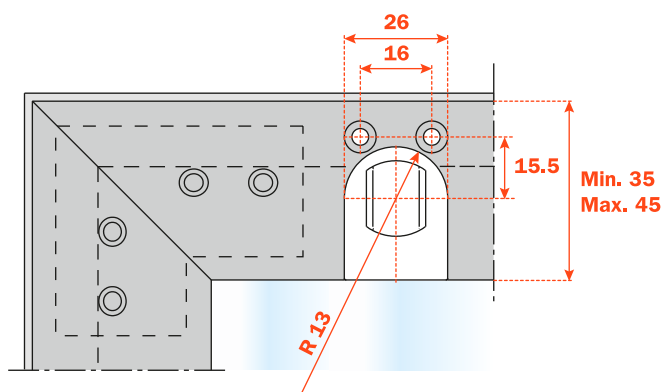
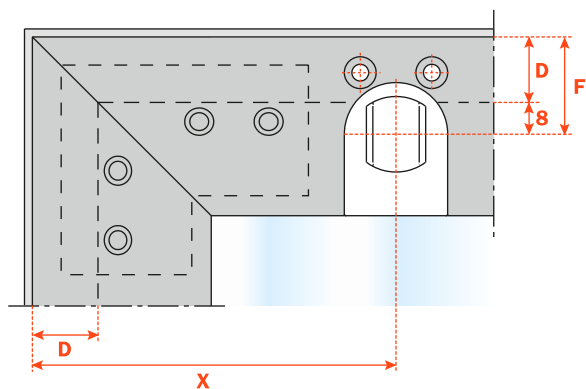

Profile with corner connector D206BS5

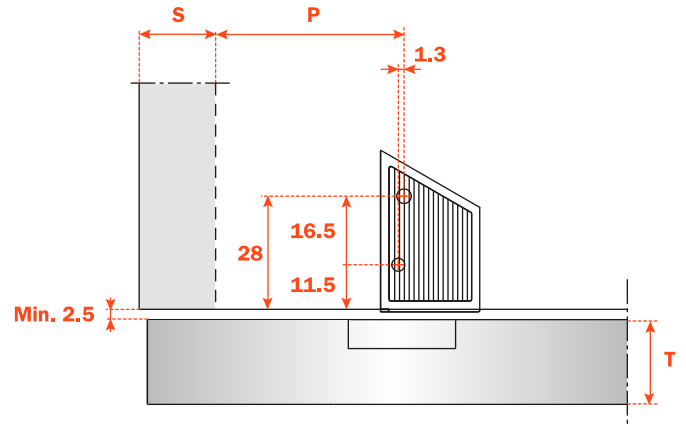
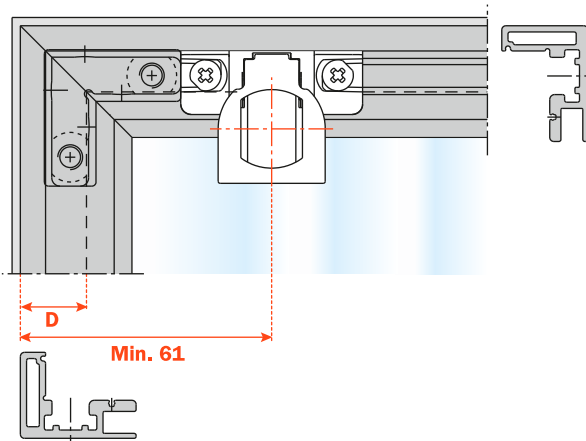

- D** = Door overlay on side and top of the cabinet
- P** = Fixing distance of PUSH = 61 (min) - D + 1.3

Profile with corner connector D206BS5L

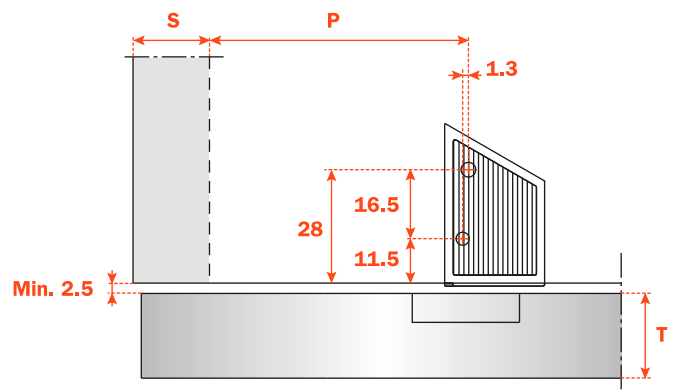
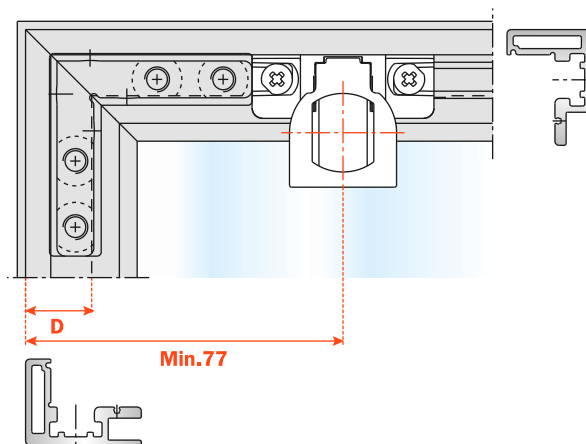

- D** = Door overlay on side and top of the cabinet
- P** = Fixing distance of PUSH = 77 (min) - D + 1.3



## Magnetic Push



Magnetic Push

## Magnetic Push - Release device to be recessed and retaining catches

**DPMB289** - beige



**DPMG289** - grey

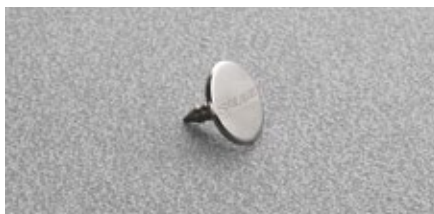

Release device.  
ø 10 mm, 40 mm length.

Retaining catch to be inserted.  
ø 11.5 mm.

**Packing**

Boxes 250 pcs.  
Cartons 1.500 pcs.

**DPMB3891** - beige



**DPMG3891** - grey



Release device.  
ø 10 mm, 40 mm length.

Retaining catch with adhesive.  
20x14 mm.

**Packing**

Boxes 250 pcs.  
Cartons 1.500 pcs.

**DPAB289** - beige



**DPAG289** - grey



Release device to be used to increase the magnetic holding strength. It must always be used together with the DPM. The suggested position of the DPM is the point of pressure on the door. The DPA can be positioned at any point along the opening edge of the door. ø 10 mm, 40 mm length.

Retaining catch to be inserted.  
ø 11.5 mm.

**Packing**

Boxes 250 pcs.  
Cartons 1.500 pcs.

**DPAB3891** - beige



**DPAG3891** - grey



Release device to be used to increase the magnetic holding strength. It must always be used together with the DPM. The suggested position of the DPM is the point of pressure on the door. The DPA can be positioned at any point along the opening edge of the door. ø 10 mm, 40 mm length.

Retaining catch with adhesive.  
20x14 mm.

**Packing**

Boxes 250 pcs.  
Cartons 1.500 pcs.

**DP80SNBR** - beige**DP80SNGR** - grey

Plastic adapter for release device.  
To be fixed with wood screws.  
7.5x32 mm drilling.  
Without assembly stop devices.  
**DP81SN\_R** = To be fixed with Euro screws.

**Packing**

Boxes 500 pcs.  
Pallets 12.000 pcs.

**DP80SNB** - beige**DP80SNG** - grey

Plastic adapter for release device.  
To be fixed with wood screws.  
7.5x32 mm drilling.  
With assembly stop devices.  
**DP81SN\_** = To be fixed with Euro screws.

**Packing**

Boxes 500 pcs.  
Pallets 12.000 pcs.

**DP82XXBR** - beige**DP82XXGR** - grey

Adjustable longitudinal plastic adapter  
for release device.  
To be fixed with wood screws.  
8+16 mm drilling.

Caps to be ordered separately.

**Packing**

Boxes 500 pcs.  
Pallets 12.000 pcs.

**DP83XXBR** - beige**DP83XXGR** - grey

Adjustable double plastic adapter for  
release device.  
To be fixed with wood screws.  
8+32 mm drilling.

Cover caps to be ordered separately.

**Packing**

Boxes 500 pcs.  
Pallets 12.000 pcs.

**DP84SNBR** - beige**DP84SNGR** - grey

Adjustable plastic adapter for release device.  
To be fixed with wood screws.  
8x32 mm drilling.

**Packing**

Boxes 500 pcs.  
Pallets 12.000 pcs.

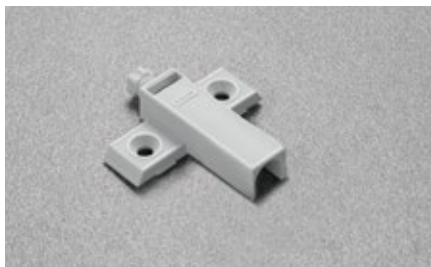
**DP85SNBR** - beige**DP85SNGR** - grey

Adjustable plastic adapter for release device.  
To be fixed with wood screws.  
37x32 mm drilling.

**Packing**

Boxes 500 pcs.  
Pallets 12.000 pcs.



## Release device application with adapter (DP80SN\_R) without assembly stop devices

Insert the release device into the adapter.  
Place the adapter to the top, the side or the base panel of the cabinet, using the drilling value 7.5x32 mm for final positioning.

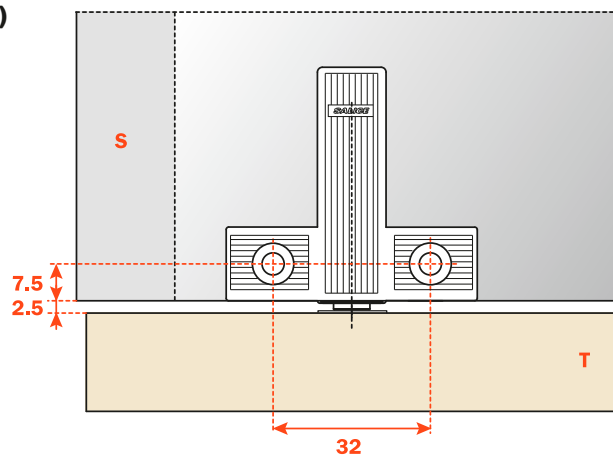

## Release device application with adapter (DP80SN\_) with assembly stop devices

Insert the release device into the adapter.  
Place the adapter to the top, the side or the base panel of the cabinet, using the assembly stop devices for final positioning.

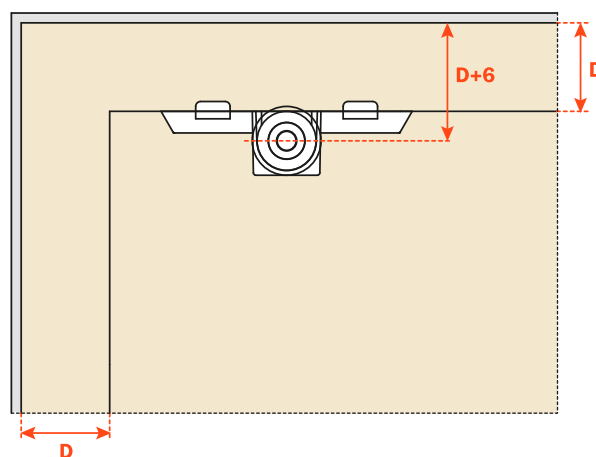

## Release device application with adapter (DP82SN\_R) without assembly stop devices.

Insert the release device frontally into the adapter.  
Place the adapter to the top, the side or the base panel of the cabinet, using the drilling value of 8+16 mm for final positioning.

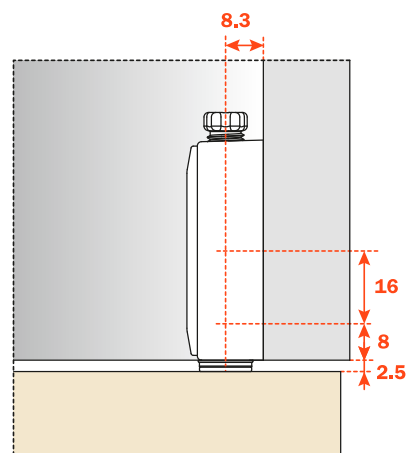

### Release device application with adapter (DP83SN\_R) without assembly stop devices

Insert the release device frontally into the adapter.  
Place the adapter to the top, the side or the base panel of the cabinet, using the drilling value of 8+32 mm for final positioning.

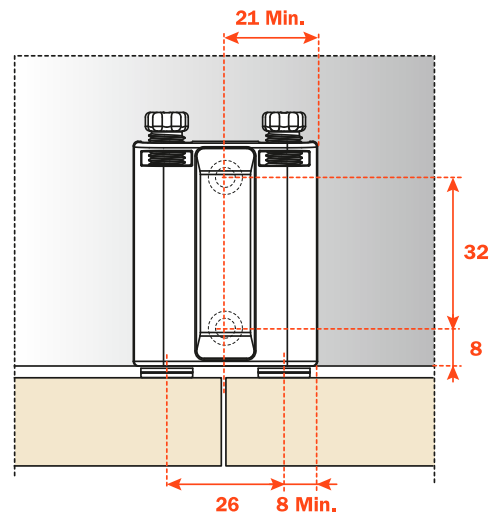

### Release device application with adapter (DP84SN\_R) with assembly stop devices

Insert the release device into the adapter.  
Place the adapter to the top, the side or base panel of the cabinet, using the assembly stop devices for final positioning.

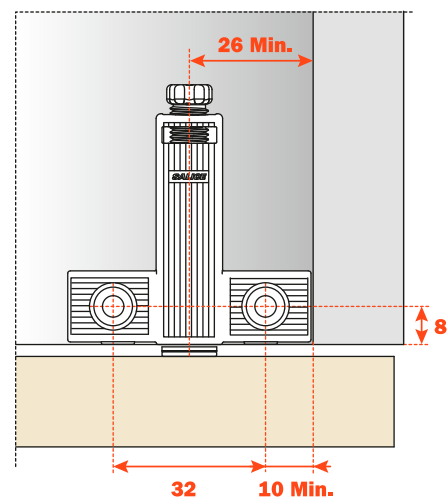

### Release device application with adapter (DP85SN\_R) without assembly stop devices

Insert the release device into the adapter.  
Place the adapter to the top, the side or base panel of the cabinet, using the drilling value of 37x32 mm for final positioning.

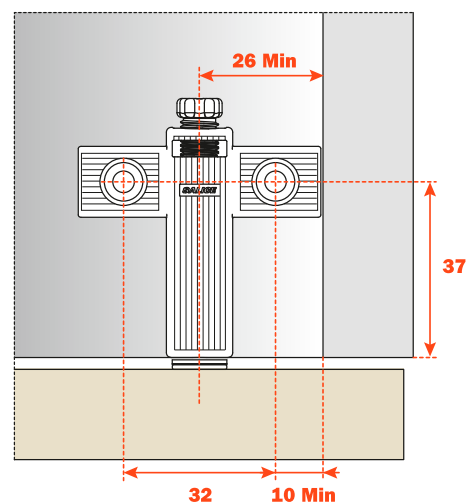

### Application of the release device to be recessed

Drill a hole  $\varnothing$  10 mm and min. 40 mm depth in the top, the side or the base panel of the cabinet.  
Insert the release device into the hole.

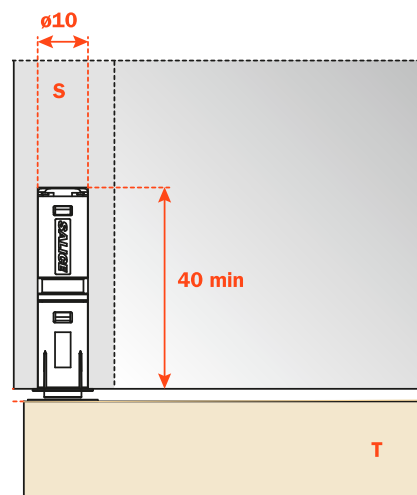

## 1 - Retaining catch with adhesive strip

Apply the retaining catch to the magnetic release device.  
Remove the protective strip from the adhesive.  
Close the door.  
In this way the retaining catch is positioned on the door.  
Reopen the door and apply a firm pressure to the retaining catch to ensure a correct installation.

### ATTENTION:

For a correct application and to ensure optimal endurance, we suggest these guidelines are followed:

- 1** - clean and degrease the door surface where the retaining catch is to be installed;
- 2** - remove the protective strip from the adhesive;
- 3** - place the retaining catch in position, in a place that is at room temperature  $\geq 10^{\circ}$  and apply a firm pressure for 10-15 seconds.

After few seconds from the installation the retaining catch is suitable for the use. After 24h the max. hold is attained.

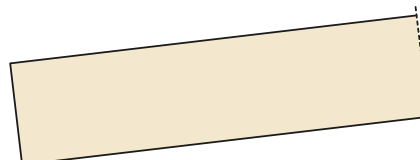
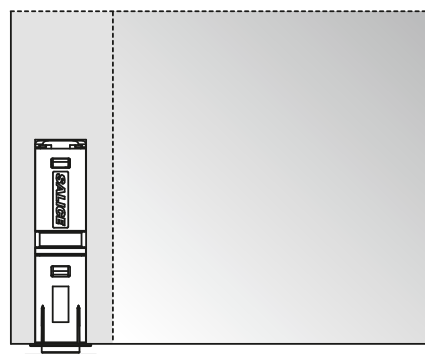

## 2 - Retaining catch to be inserted

Apply the retaining catch to the magnetic release device.  
Close the door.  
The point of the retaining catch will show where to insert it.  
Reopen the door and press the retaining catch.

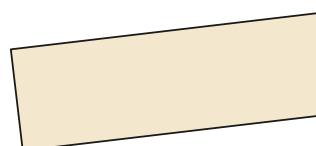
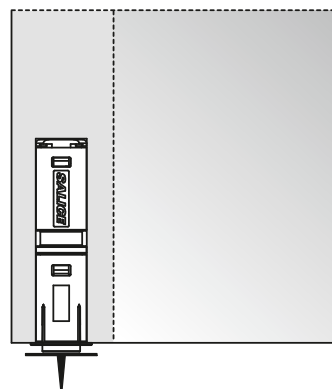



## Push - Series 200 hinges

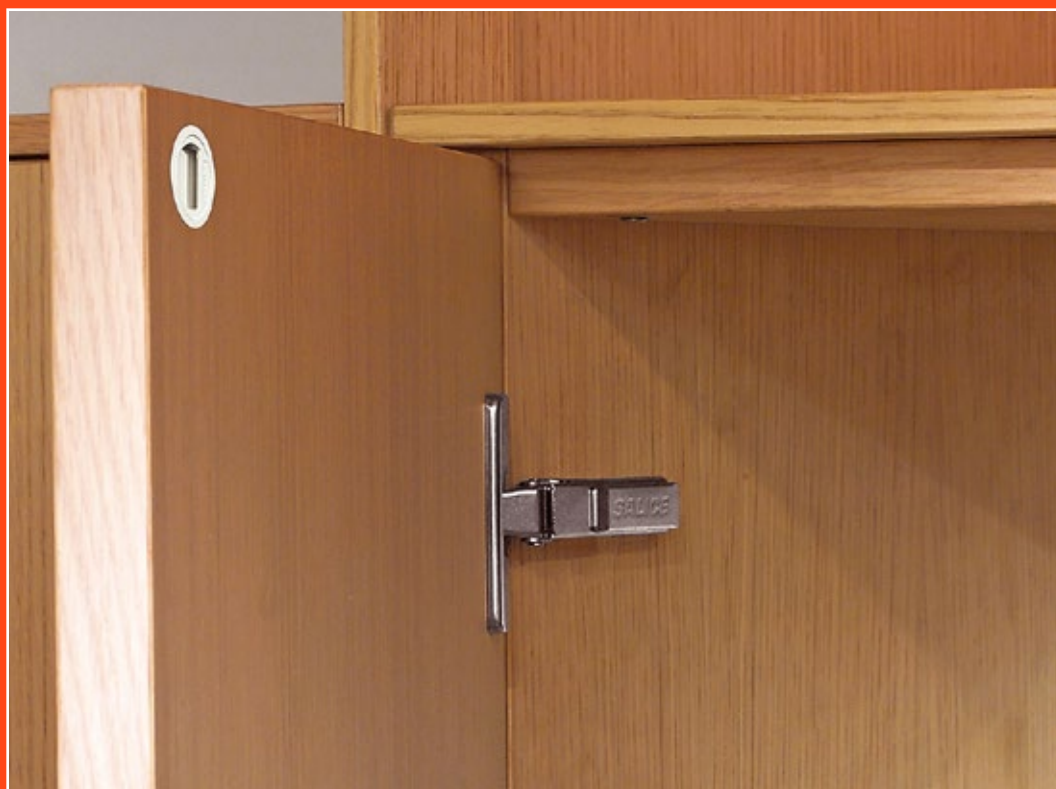



The Series 200 make up an integrated system of hinges developed to provide a solution to any situation involving concealed hinges.  
**Bright nickel plated steel cup and arm.**  
**Dimensions of the  $\varnothing$  35 mm cup.**

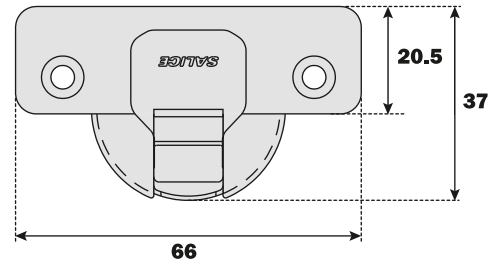

Constant "L" value of 0.7 mm (it does not change during side adjustment).

Approx. number of hinges required according to the door dimension and weight.

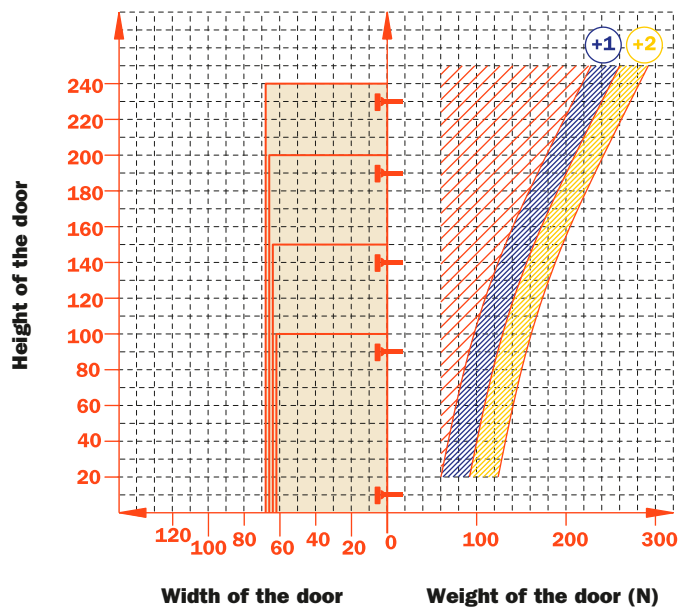

### Adjustments

Compensating side adjustment from - 1.5 to + 4.5 mm.  
 Height adjustment  $\pm$  2 mm.  
 Depth adjustment with Series 200 mounting plates + 2.8 mm.  
 Depth adjustment with Domi snap-on mounting plates from - 0.5 mm to + 2.8 mm.  
 Anti-sliding safety stop.

### Mounting plates

Symmetrical and asymmetrical bright nickel plated steel or die-cast Series 200 mounting plates.  
 Snap-on assembly on Domi mounting plates.  
 Positioning with pre-determined stop on traditional Series 200 mounting plates.

N.B. : Use POZIDRIVE No. 2 screwdrivers for all screws.

	94°	110°	155°						
Wood screw	A	A	A	P	P	P	U	U	U

	94°	110°	155°						
Rapido	6	6	6	7	7	7	2	2	2
Dowel	B	B	B	R	R	R	W	W	W
Logica	I	I	I	J	J	J	Q	Q	Q

Use this table to identify the available drillings and fixings.  
 Fill the third position of the hinge code number with the letter or the number corresponding to your choice. I.e.: C2\_PA99.

↑  
 Fill this position with the chosen letter or number.

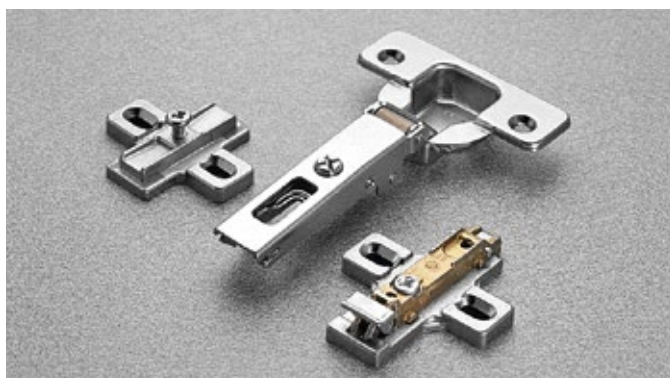

## Technical information

**Push hinges are equipped with a special spring that acts to open the door independently of the release device.**

For thick doors up to 35 mm, with special profiles.  
11 mm deep metal cup.

94° opening.

Possible drilling distance on the door (K): from 3 to 9 mm.  
Compatible with all traditional Series 200 mounting plates  
and with all Domi snap-on mounting plates.

## Space needed to open the door

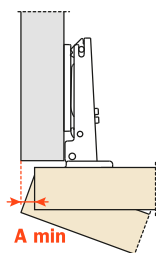

T=	19	20	21	22	23	24	25	26	27	28	29	30	31	32	33	34	35
K=3	<b>A=</b> 0.1	0.2	0.3	0.4	0.5	0.7	0.8	1.0	1.6	2.6	3.5	4.5	5.4	6.4	7.4	8.3	9.3
K=4	<b>A=</b> 0.1	0.2	0.3	0.4	0.5	0.7	0.8	1.0	1.2	1.9	2.8	3.8	4.7	5.7	6.6	7.6	8.6
K=5	<b>A=</b> 0.1	0.2	0.3	0.4	0.5	0.7	0.8	1.0	1.2	1.4	2.2	3.1	4.1	5.0	5.9	6.9	7.8
K=6	<b>A=</b> 0.1	0.2	0.3	0.4	0.5	0.6	0.8	1.0	1.2	1.4	1.7	2.6	3.5	4.4	5.3	6.2	7.2
K=7	<b>A=</b> 0.1	0.2	0.3	0.4	0.5	0.6	0.8	1.0	1.1	1.3	1.6	2.1	3.0	3.8	4.7	5.6	6.5
K=8	<b>A=</b> 0.1	0.2	0.3	0.4	0.5	0.6	0.8	0.9	1.1	1.3	1.6	1.8	2.5	3.3	4.2	5.1	6.0
K=9	<b>A=</b> 0.1	0.2	0.3	0.4	0.5	0.6	0.8	0.9	1.1	1.3	1.5	1.8	2.1	2.9	3.7	4.6	5.4

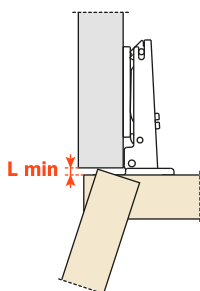

K=	3	4	5	6	7	8	9
<b>L=</b>	0.0	0.0	0.0	0.0	0.0	0.3	1.3

The above values are calculated on the assumption that the doors have square edges. They are reduced if the doors have radiussed edges.

## Projection of the door

Projection of the door from the cabinet side at the max. opening. The figures are based on a straight arm hinge, H=0 mm thickness of mounting plate and K value = 3 mm.

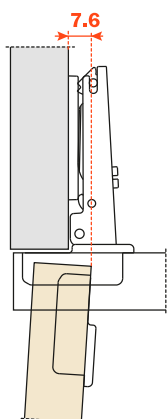

## "C" value

With this formula you can obtain the max. thickness of the moulded door that can be opened without touching adjacent carcass sides, doors or walls, whilst bearing in mind the above L-K-T values.

$$C = 23 + K + A$$

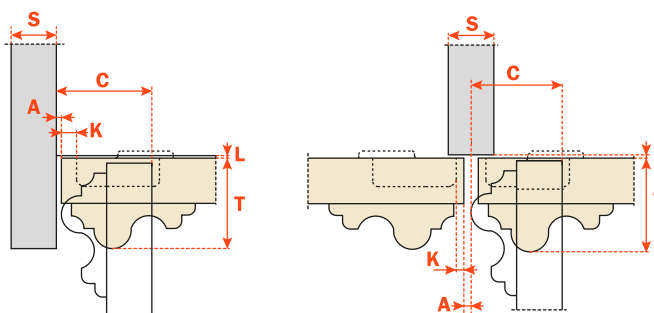

**Packing**

Boxes 300 pcs.  
Pallets 7.200 pcs.

Use these formulas to determine the type of hinge arm, the drilling distance "K" and the height of the mounting plate "H" which is necessary to solve each application problem.

Use the tables "Drillings and fixings" at page 207 to complete the code number of the desired hinge.

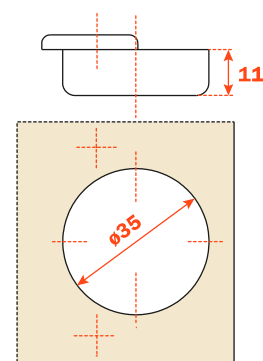

**Arm 0**

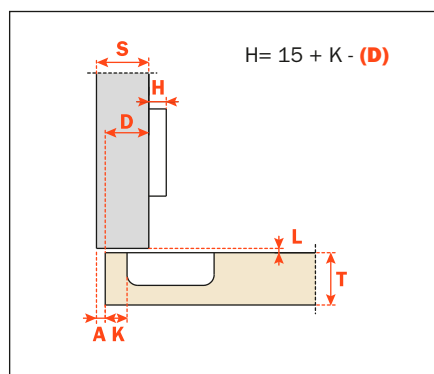

**C2\_VA99**

**Arm 5**

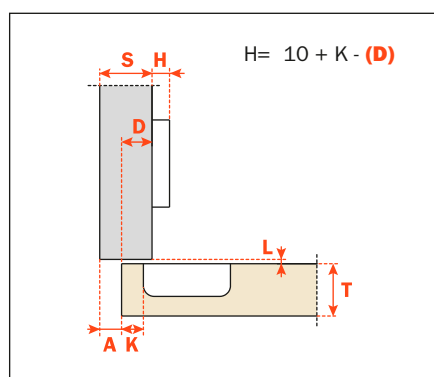

**C2\_VD99**

**Arm 9**

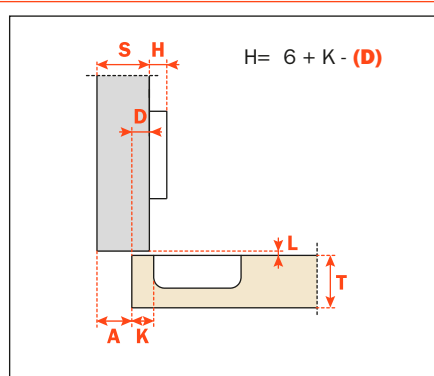

**C2\_VG99**

**Arm 17**

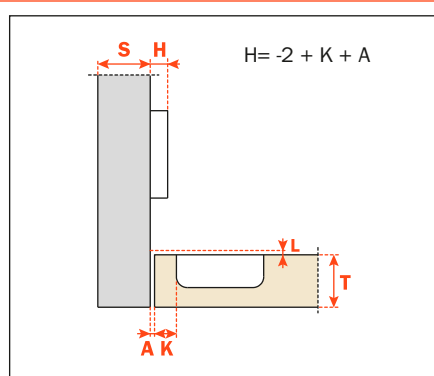

**C2\_VP99**



## Technical information

**Push hinges are equipped with a special spring that acts to open the door independently of the release device.**

When a greater opening angle is required.  
11 mm deep metal cup.

110° opening.

Possible drilling distance on the door (K): from 3 to 6 mm.  
Compatible with all traditional Series 200 mounting plates and with all Domi snap-on mounting plates.

## Space needed to open the door

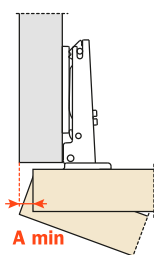

	T=	16	17	18	19	20	21	22	23	24	25	26
K=3	<b>A=</b>	0.5	0.7	0.9	1.2	1.5	1.8	2.4	3.7	5.1	6.5	7.8
K=4	<b>A=</b>	0.5	0.7	0.9	1.2	1.5	1.8	2.1	2.7	4.1	5.5	6.8
K=5	<b>A=</b>	0.5	0.7	0.9	1.2	1.5	1.8	2.1	2.6	3.1	4.1	5.4
K=6	<b>A=</b>	0.5	0.7	0.9	1.2	1.5	1.8	2.1	2.5	3.0	3.5	4.4

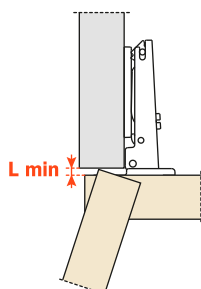

	T=	16	17	18	19	20	21	22	23	24	25	26
K=3	<b>L=</b>	0.0	0.0	0.0	0.0	0.2	0.5	0.8	1.1	1.4	1.7	1.9
K=4	<b>L=</b>	0.0	0.0	0.3	0.6	0.9	1.2	1.4	1.7	2.0	2.3	2.6
K=5	<b>L=</b>	1.1	1.3	1.6	1.8	2.1	2.3	2.6	2.9	3.1	3.4	3.6
K=6	<b>L=</b>	2.0	2.3	2.5	2.8	3.1	3.3	3.6	3.8	4.1	4.3	4.6

**The above values are calculated on the assumption that the doors have square edges. They are reduced if the doors have radiussed edges.**

## Projection of the door

Projection of the door from the cabinet side at the max. opening.  
The figures are based on a straight arm hinge, H=0 mm thickness of mounting plate and K value = 3 mm.

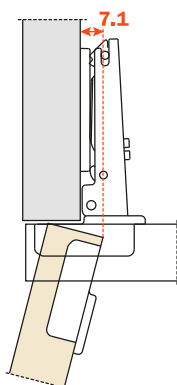

## "C" value

With this formula you can obtain the max. thickness of the moulded door that can be opened without touching adjacent carcass sides, doors or walls, whilst bearing in mind the above L-K-T values.

$$C = 20 + K + A$$

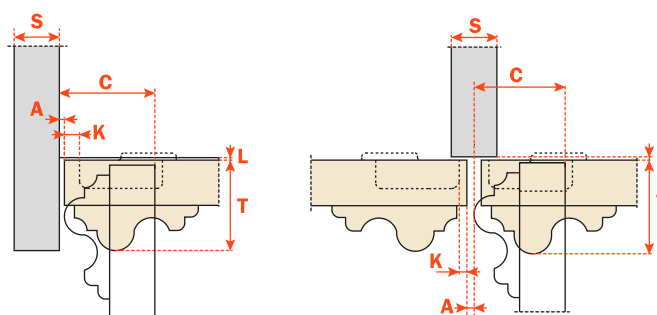

**Packing**

Boxes 300 pcs.  
Pallets 7.200 pcs.

Use these formulas to determine the type of hinge arm, the drilling distance "K" and the height of the mounting plate "H" which is necessary to solve each application problem.

Use the tables "Drillings and fixings" at page 207 to complete the code number of the desired hinge.

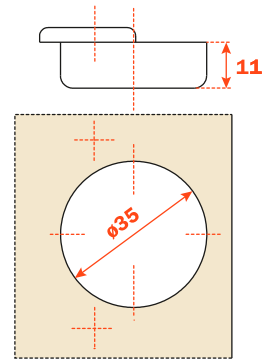

**Arm 0**

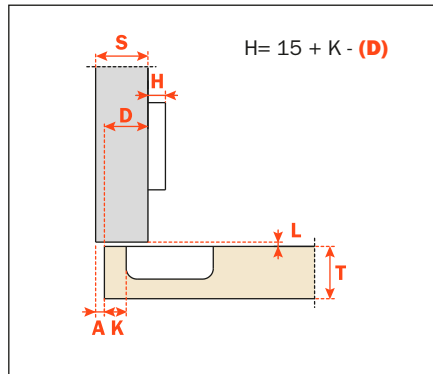

**C2\_PA99**

**Arm 5**

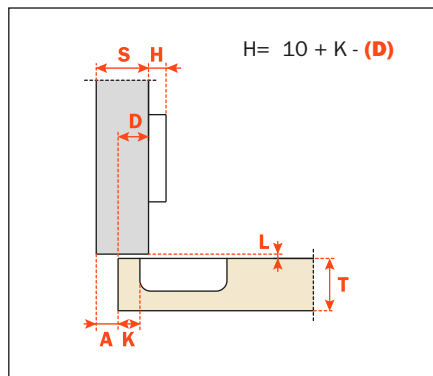

**C2\_PD99**

**Arm 9**

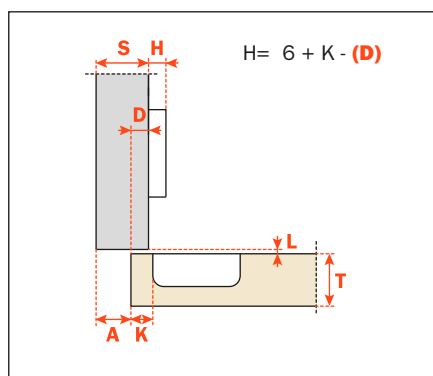

**C2\_PG99**

**Arm 17**

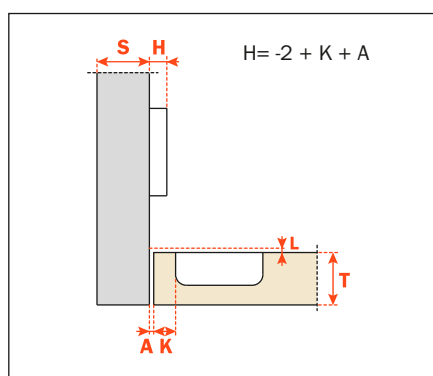

**C2\_PP99**



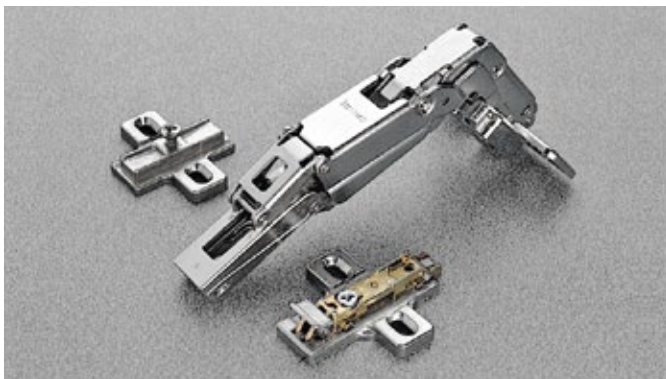

**Technical information**

**Push hinges are equipped with a special spring that acts to open the door independently of the release device.**

For thick doors min. 10 mm.  
 8 mm deep die-cast cup.  
 With 0 mm door protrusion only with straight arm hinge.  
 155° opening.  
 Possible drilling distance on the door (K): from 3 to 8 mm.  
 Compatible with all traditional Series 200 mounting plates and with all Domi snap-on mounting plates.

**Space needed to open the door**

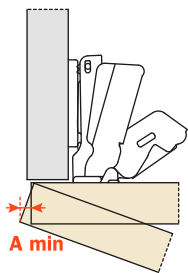

	T=	16	18	20	22
K=3	<b>A=</b>	0.0	0.0	0.3	1.2
K=4	<b>A=</b>	0.0	0.4	0.4	1.3
K=5	<b>A=</b>	0.0	0.1	0.5	1.6
K=6	<b>A=</b>	0.0	0.1	1.2	3.0
K=7	<b>A=</b>	0.0	0.1	0.7	2.5
K=8	<b>A=</b>	0.0	0.1	0.6	1.9

**The above values are calculated on the assumption that the doors have square edges. They are reduced if the doors have radiussed edges.**

**“C” value**

For spaces with removable components. The door opens at 90° with lateral door protrusion of 2 mm. The figures are based on a straight arm hinge and H=0 thickness of mounting plate.

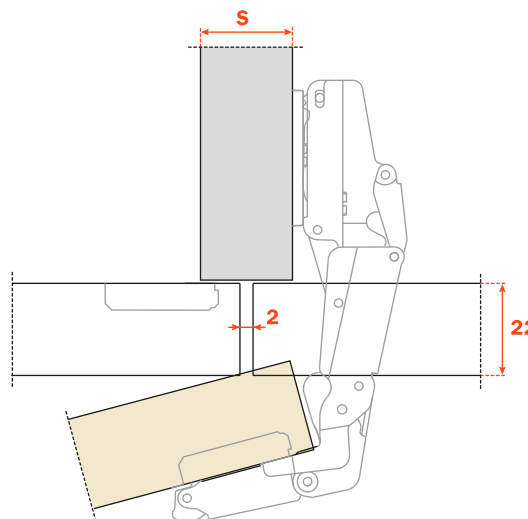
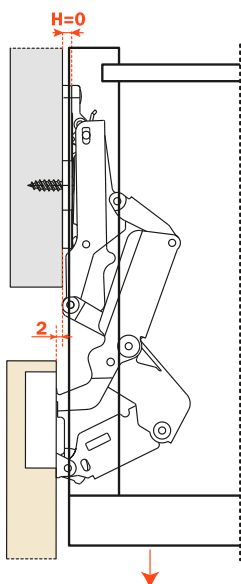



**Packing**

Boxes 100 pcs.  
Pallets 2.400 pcs.

Use these formulas to determine the type of hinge arm, the drilling distance "K" and the height of the mounting plate "H" which is necessary to solve each application problem.

To limit the opening of the hinge, see page 362 chapter "Accessories".

Use the tables "Drillings and fixings" at page 207 to complete the code number of the desired hinge.

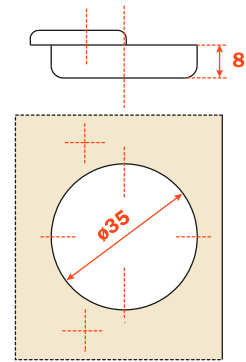

**Arm 0**

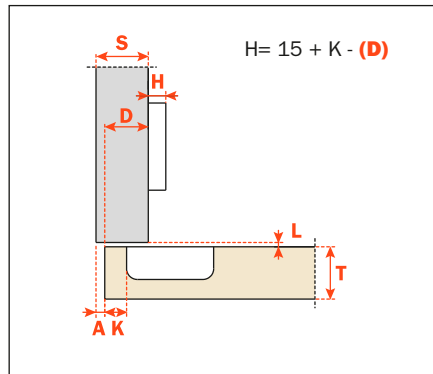

**C2\_UA99**

**Arm 5**

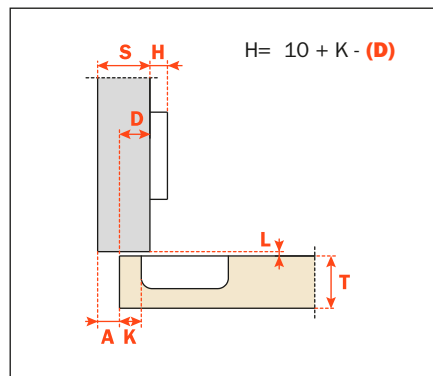

**C2\_UD99**

**Arm 9**

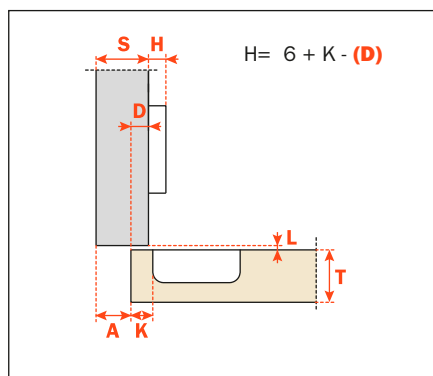

**C2\_UG99**

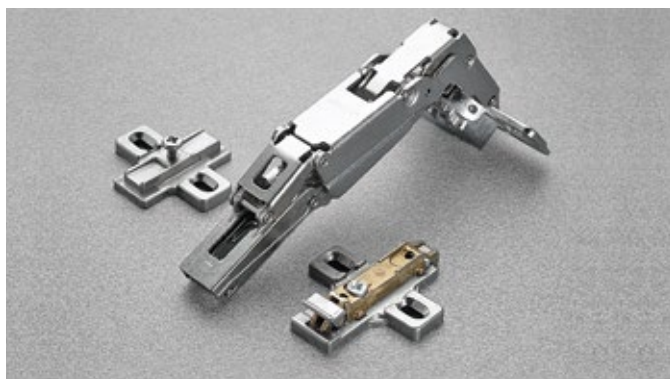

**Technical information**

**Push hinges are equipped with a special spring that acts to open the door independently of the release device.**

For thick doors up to 35 mm.  
 Hinge with greater opening angle and reduced operating profile.  
 11 mm deep die-cast cup.  
 155° opening.  
 Possible drilling distance on the door (K): from 3 to 9 mm.  
 Compatible with all traditional Series 200 mounting plates and with all Domi snap-on mounting plates.

**Space needed to open the door**

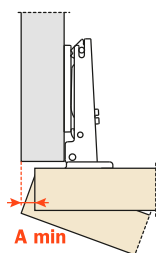

T=	26	27	28	29	30	31	32	33	34	35
K=3	<b>A=</b> 0.0	0.0	0.0	0.8	3.0	4.8	7.1	11.7	16.4	20.7
K=4	<b>A=</b> 0.0	0.0	0.0	0.8	2.5	4.0	6.2	10.6	15.0	19.7
K=5	<b>A=</b> 0.0	0.0	0.0	0.8	2.0	3.4	4.8	9.8	14.1	18.4
K=6	<b>A=</b> 0.0	0.0	0.0	0.8	1.5	2.8	4.2	8.7	13.2	17.8
K=7	<b>A=</b> 0.0	0.0	0.0	0.8	1.4	2.3	3.0	7.8	12.0	16.7
K=8	<b>A=</b> 0.0	0.0	0.0	0.2	0.9	1.9	2.7	7.0	11.2	15.7
K=9	<b>A=</b> 0.0	0.0	0.0	0.2	0.7	1.5	2.1	5.9	10.4	15.0

**The above values are calculated on the assumption that the doors have square edges. They are reduced if the doors have radiussed edges.**

**“C” value**

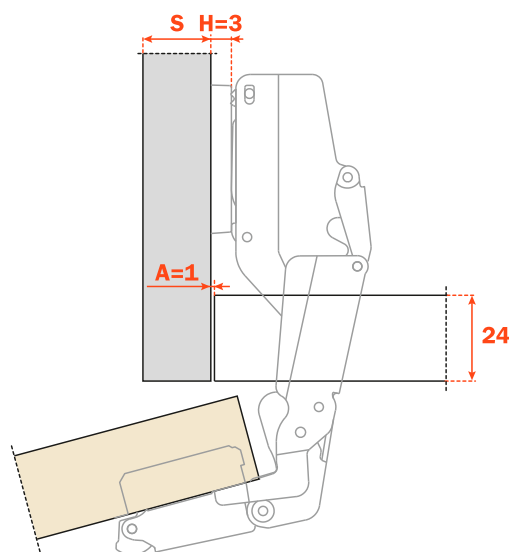
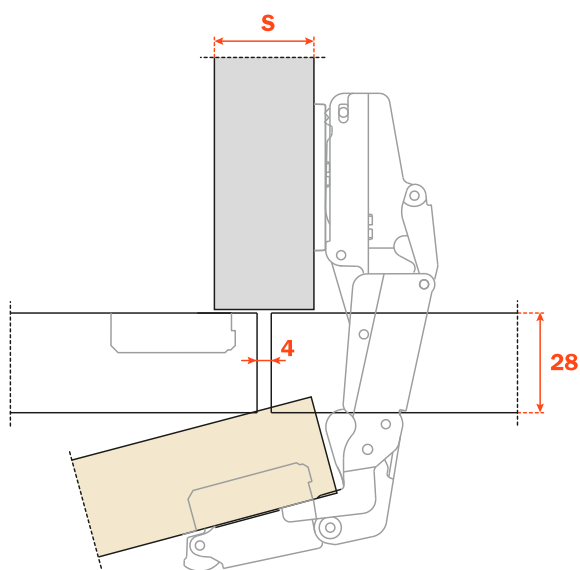

**Packing**

Boxes 100 pcs.  
Pallets 2.400 pcs.

Use these formulas to determine the type of hinge arm, the drilling distance "K" and the height of the mounting plate "H" which is necessary to solve each application problem.

To limit the opening of the hinge, see page 362 chapter "Accessories".

Use the tables "Drillings and fixings" at page 207 to complete the code number of the desired hinge.

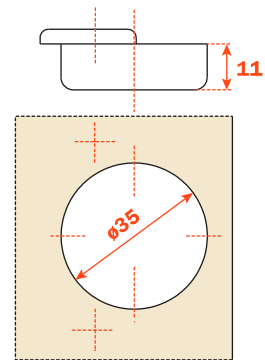

Arm 0

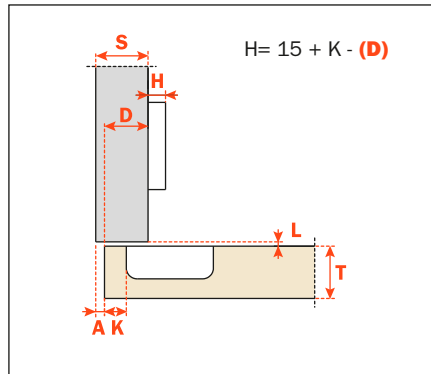

**C2\_TA99**

Arm 5

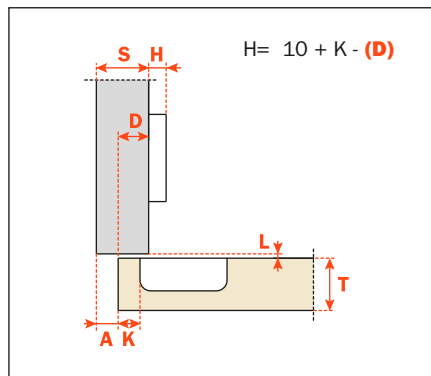

**C2\_TD99**

Arm 9

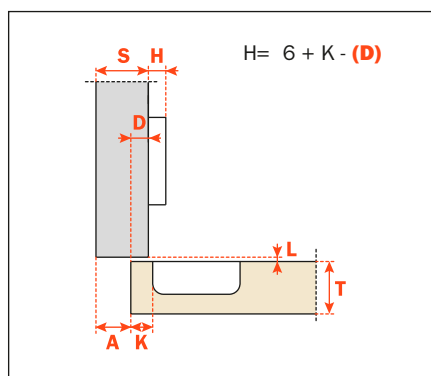

**C2\_TG99**



**Technical information**

**Push hinges are equipped with a special spring that acts to open the door independently of the release device.**

**Hinges for wooden doors with positive angled assembly.**  
 11 mm deep metal cup.  
 94° opening.  
 Possible drilling distance on the door (K): from 3 to 9 mm.  
 Compatible with all traditional Series 200 mounting plates and with all Domi snap-on mounting plates.

**Packing**

Boxes 150 pcs.  
 Pallets 3.600 pcs.

The solution of assembly problems where doors are mounted at a positive angle requires the verification of drilling distances by a practical trial. Please do not hesitate to consult our technical support department for assistance.

Use the tables "Drillings and fixings" at page 207 to complete the code number of the desired hinge.

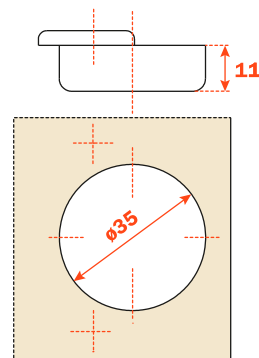

Arm **15°**

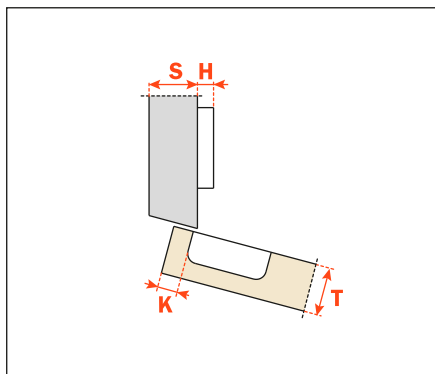

**C2\_VZ99**

Arm **24°**

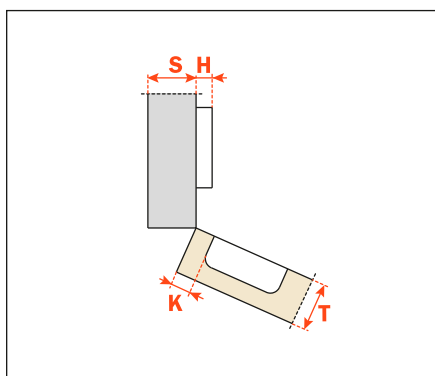

**C2\_VU99**

Arm **30°**

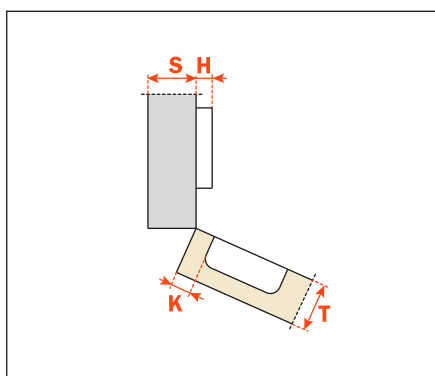

**C2\_VE99**

Arm 30°

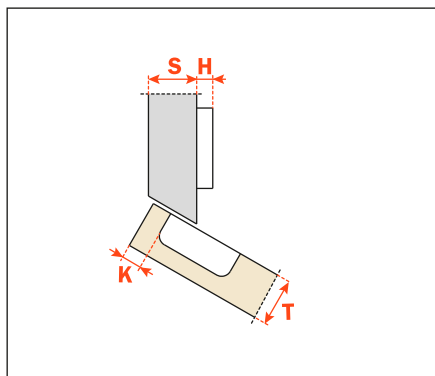

**C2\_VT99**

Arm 37°

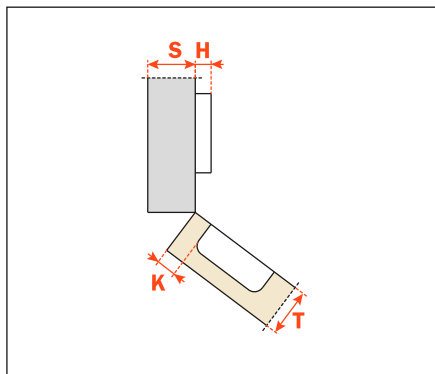

**C2\_VK99**

Arm 45°

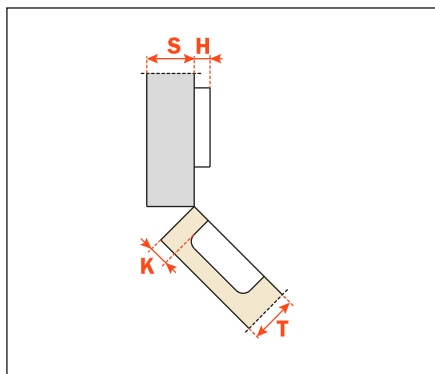

**C2\_VM99**

Arm 45°

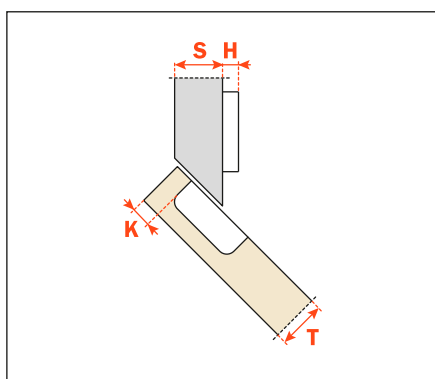

**C2\_VV99**

Arm 45°

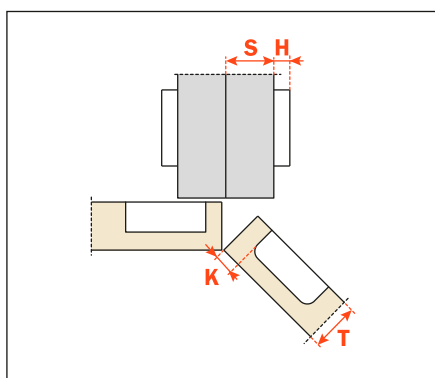

**C2\_VM99AC**





**Technical information**

**Push hinges are equipped with a special spring that acts to open the door independently of the release device.**

**Crampon hinges.**

**For cabinet sides with 37x32 mm standard drilling.**

11 mm deep metal cup.

94° opening.

Possible drilling distance on the door (K): from 3 to 9 mm.

Compatible with all traditional Series 200 mounting plates and with all Domi snap-on mounting plates.

**Packing**  
Boxes 150 pcs.  
Pallets 3.600 pcs.

**E min:**  
61 mm for Series 200 mounting plates.  
70 mm for Domi snap-on mounting plates.  
74 mm for Domi snap-on mounting plates with back cam.

Use the tables "Drillings and fixings" at page 207 to complete the code number of the desired hinge.

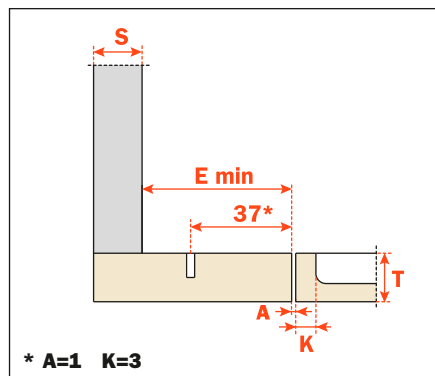
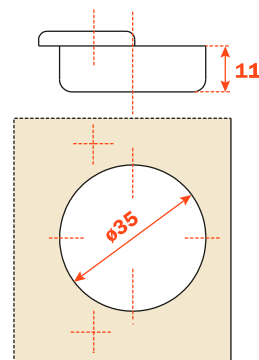

**C2\_VN99AC**

Heights of mounting plates for every assembly.

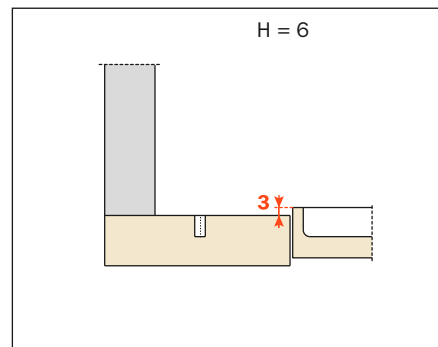
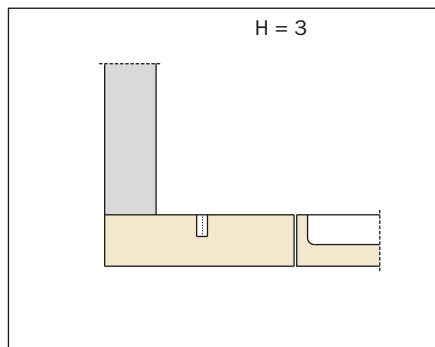
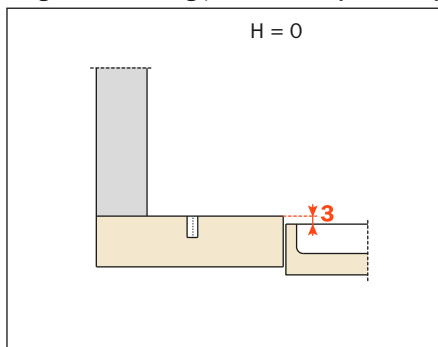



### Technical information

Push hinges are equipped with a special spring that acts to open the door independently of the release device.

#### Crampon hinges.

For smaller spaces with 15x32 mm drilling.

11 mm deep metal cup.

94° opening.

Possible drilling distance on the door (K): from 3 to 9 mm.

Compatible with all traditional Series 200 mounting plates, 28x32 mm drilling.

**NOT COMPATIBLE** with Domi snap-on mounting plates.

**Packing**  
Boxes 150 pcs.  
Pallets 3.600 pcs.

Use the tables "Drillings and fixings" at page 207 to complete the code number of the desired hinge.

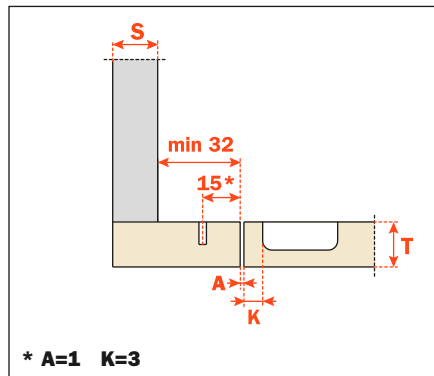
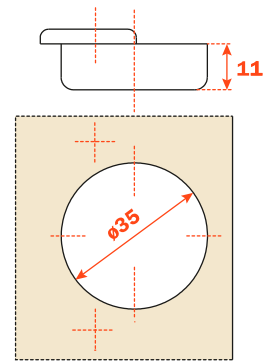

**C2\_VN99**

Heights of mounting plates for every assembly.

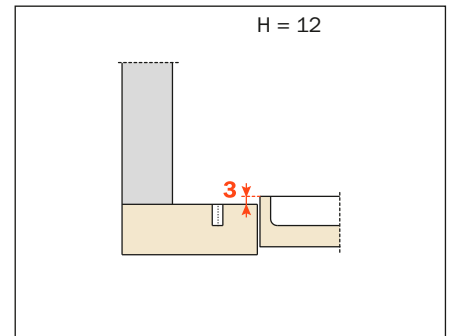
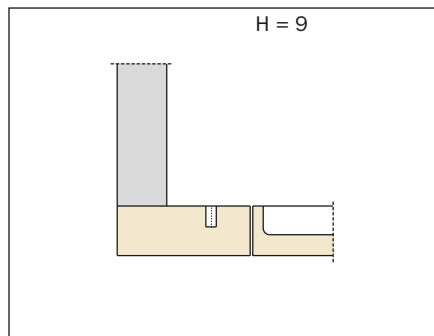
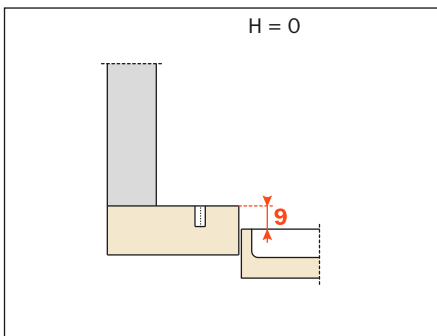





## Push - Hinges for metal profiles



# Push - Practical hinges - 105° opening



## Technical information

**Push hinges are equipped with a special spring that acts to open the door independently of the release device.**

Hinges for the Practical system have been developed for use with special metal profiles. The particular fixing system does not require any profile working. The hinge can be therefore assembled at any point of the frame.

105° opening.

Compatible with all traditional Series 200 mounting plates and with all Domi snap-on mounting plates.

### Packing

Boxes 150 pcs.

Pallets 3.600 pcs.

### Arm 0

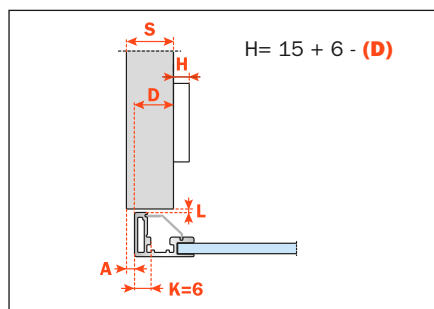

**C20PA99**

### Arm 5

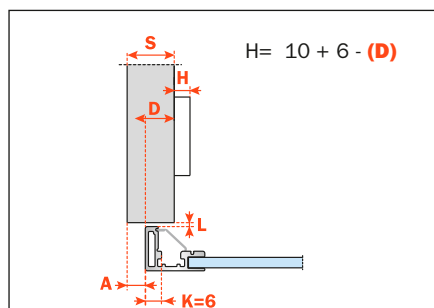

**C20PD99**

### Arm 9

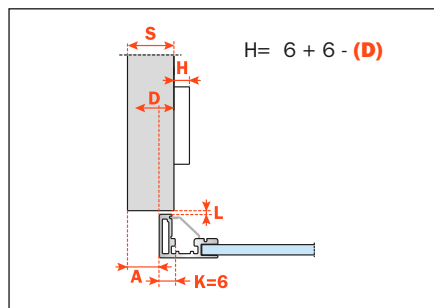

**C20PG99**

### Arm 17

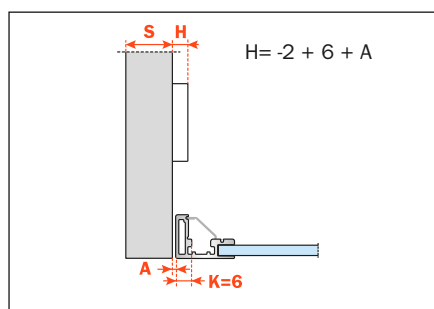

**C20PP99**



**Technical information**

**Push hinges are equipped with a special spring that acts to open the door independently of the release device.**

**Hinges for doors with positive angled assembly.**

Hinges for the Practical system have been developed for use with special metal profiles. The particular fixing system does not require any profile working. The hinge can be therefore assembled at any point of the frame.

105° opening.

Compatible with all traditional Series 200 mounting plates and with all Domi snap-on mounting plates.

**Packing**

Boxes 150 pcs.

Pallets 3.600 pcs.

**Arm 30°**

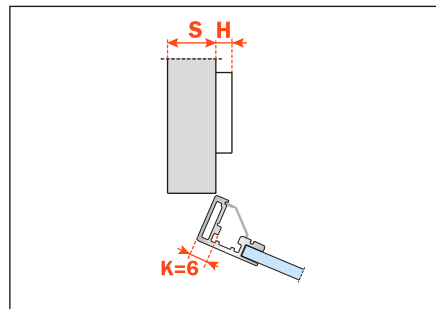

**C20PE99**

**Arm 45°**

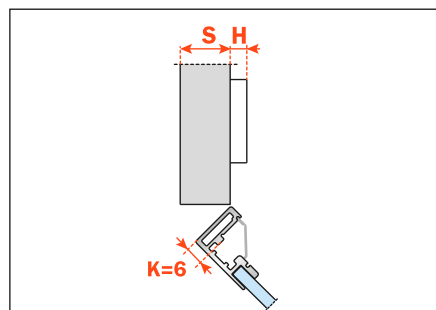

**C20PM99**

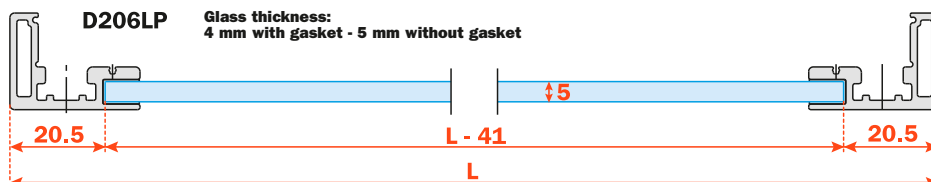
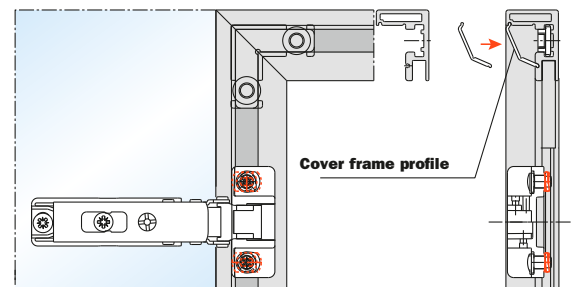
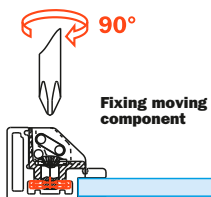
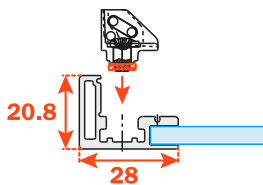

**D206LP**

Glass thickness:  
4 mm with gasket - 5 mm without gasket



**Packing**

Boxes 150 pcs.  
Pallets 3.600 pcs.

**Technical information**

**Push hinges are equipped with a special spring that acts to open the door independently of the release device.**

**Crampon hinges.**

**For cabinet sides with 37x32 mm standard drilling.**

Hinges for the Practical system have been developed for use with special metal profiles. The particular fixing system does not require any profile working. The hinge can be therefore assembled at any point of the frame.

105° opening.

Compatible with all traditional Series 200 mounting plates and with all Domi snap-on mounting plates.

**E min:**

61 mm for Series 200 mounting plates.

70 mm for Domi snap-on mounting plates.

74 mm for Domi snap-on mounting plates with back cam.

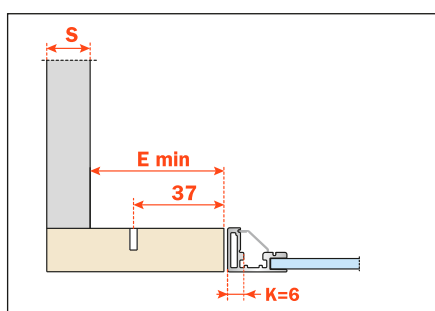

**C20PN99AC**



**Packing**

Boxes 150 pcs.  
Pallets 3.600 pcs.

**Technical information**

**Push hinges are equipped with a special spring that acts to open the door independently of the release device.**

**Crampon hinges.**

**For smaller spaces with 15x32 mm drilling.**

Hinges for the Practical system have been developed for use with special metal profiles. The particular fixing system does not require any profile working. The hinge can be therefore assembled at any point of the frame.

105° opening.

Compatible with all traditional Series 200 mounting plates, 28 x 32 mm drilling.

**NOT COMPATIBLE** with Domi snap-on mounting plates.

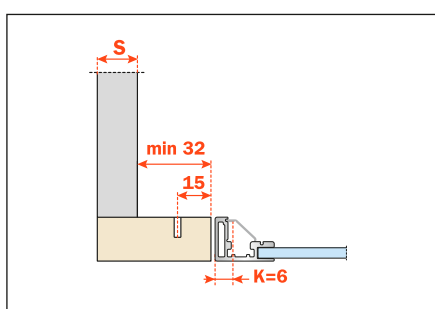

**C20PN99**





**Technical information**

**Push hinges are equipped with a special spring that acts to open the door independently of the release device.**

Hinges specially developed for use with metal profiles. 105° opening.  
 We recommend the use of self-threading screws B 3.5 x 9.5 DIN 7982 to fix C2ZP hinges.  
 Compatible with all traditional Series 200 mounting plates and with all Domi snap-on mounting plates.

**Packing**

Boxes 150 pcs.  
 Pallets 3.600 pcs.

**Arm 0**

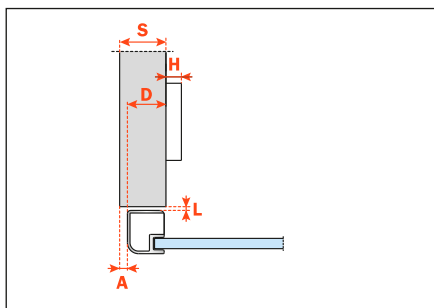

**C2ZPA99**

**Arm 5**

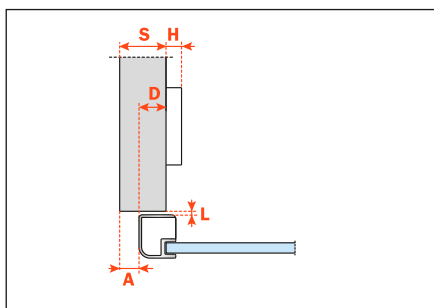

**C2ZPD99**

**Arm 9**

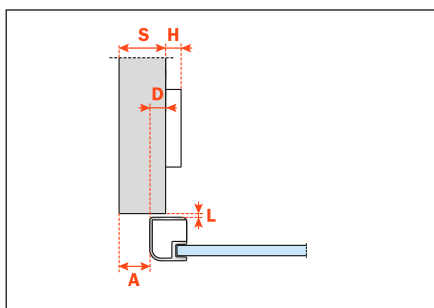

**C2ZPG99**

**Arm 17**

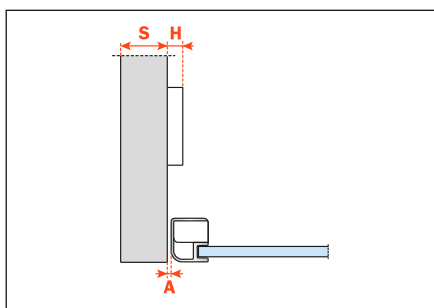

**C2ZPP99**



## Technical information

**Push hinges are equipped with a special spring that acts to open the door independently of the release device.**

### Hinges for doors with positive angled assembly.

Hinges specially developed for use with metal profiles.  
105° opening.

We recommend the use of self-threading screws B 3.5 x 9.5  
DIN 7982 to fix C2ZP hinges.

Compatible with all traditional Series 200 mounting plates  
and with all Domi snap-on mounting plates.

### Packing

Boxes 150 pcs.  
Pallets 3.600 pcs.

### Arm 30°

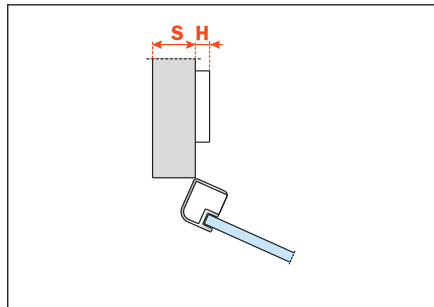

**C2ZPE99**

### Arm 45°

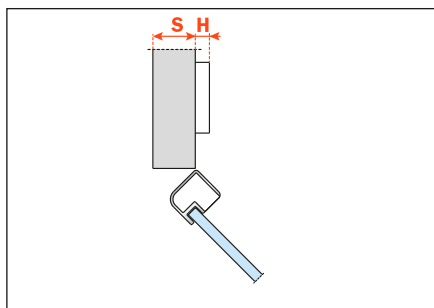

**C2ZPM99**

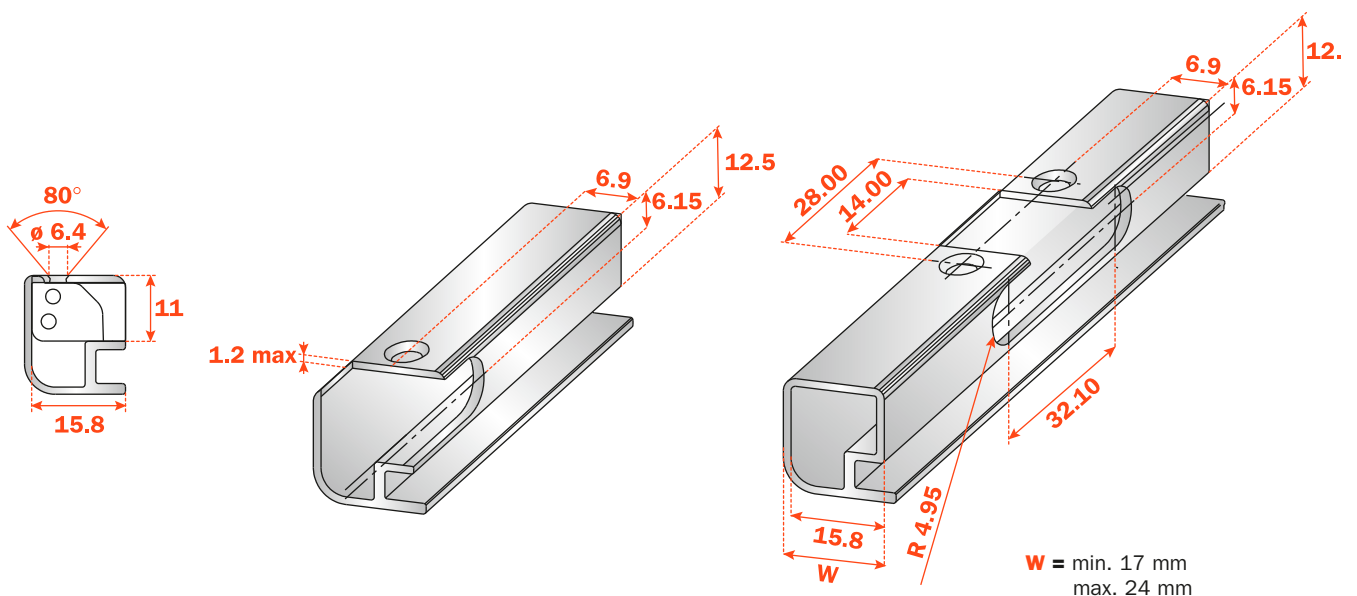





**Technical information**

**Push hinges are equipped with a special spring that acts to open the door independently of the release device.**

**Crampon hinges.**

**For cabinet sides with 37x32 mm standard drilling.**

Hinges specially developed for use with metal profiles.  
105° opening.

We recommend the use of self-threading screws B 3.5 x 9.5 DIN 7982 to fix C2ZP hinges.

Compatible with all traditional Series 200 mounting plates and with all Domi snap-on mounting plates.

**Packing**

Boxes 150 pcs.  
Pallets 3.600 pcs.

**E min:**

61 mm for Series 200 mounting plates.  
70 mm for Domi snap-on mounting plates.  
74 mm for Domi snap-on mounting plates with back cam.

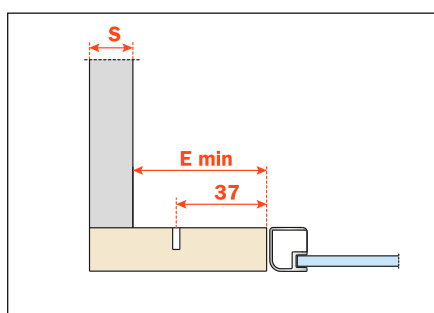

**C2ZPN99AC**



**Technical information**

**Push hinges are equipped with a special spring that acts to open the door independently of the release device.**

**Crampon hinges.**

**For smaller spaces with 15x32 mm drilling.**

Hinges specially developed for use with metal profiles.  
105° opening.

We recommend the use of self-threading screws B 3.5 x 9.5 DIN 7982 to fix C2ZP hinges.

Compatible with all traditional Series 200 mounting plates, drilling 28x32 mm.

**NOT COMPATIBLE** with Domi snap-on mounting plates.

**Packing**

Boxes 150 pcs.  
Pallets 3.600 pcs.

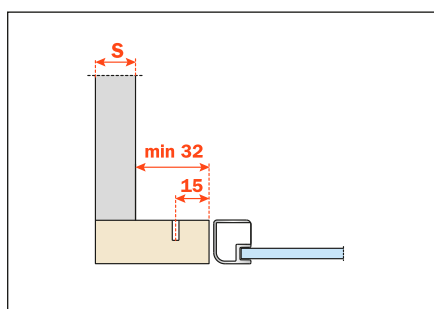

**C2ZPN99**



## Push - Series B hinges



# Push - Series B hinges for glass doors

## Technical features

No drilling of the glass is required.  
Bright nickel plated die-cast cup and arm.

### Disclaimer

Salice Series B (CBG) hinges have been developed for use on glass doors and mirrors. Salice will accept no responsibility for any problems associated with the type of adhesive or method of application when used in conjunction with Series B hinges, nor for any consequences of the incorrect mounting of the door. It is recommended that the selected adhesive is subjected to prior testing. The adhesive may be considered appropriate if the plate, when fixed to the glass, can sustain a minimum torsion load of 160 Nm.

Constant "L" value of 0.7 mm (it does not change during side adjustment).

Approx. number of hinges required according to the door dimension and weight.

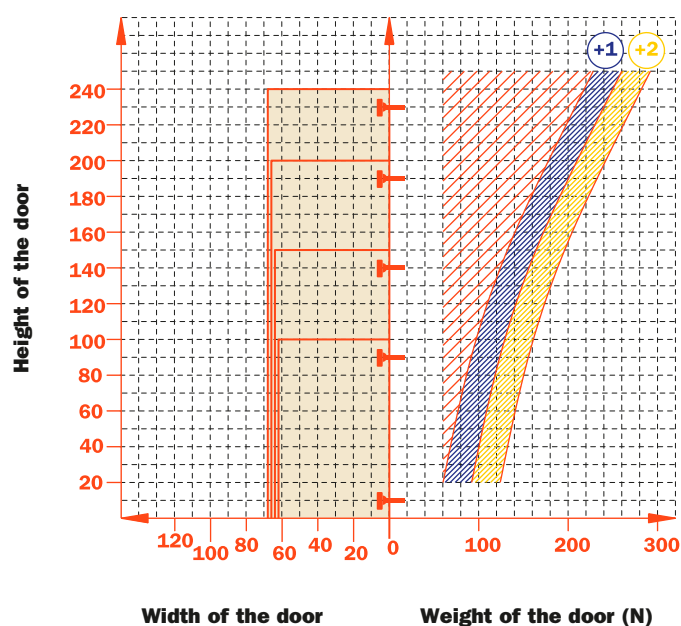

### Adjustments

Compensated side adjustment from -1.5 mm to +4.5 mm.  
Height adjustment  $\pm 2$  mm.  
Depth adjustment with Series 200 mounting plates +2.8 mm.  
Depth adjustment with Domi snap-on mounting plates from -0.5 mm to +2.8 mm.  
Anti-sliding safety stop.

### Mounting plates

Symmetrical and asymmetrical bright nickel plated steel or die-cast Series 200 mounting plates.  
Snap-on assembly on Domi mounting plates.  
Positioning with pre-determined stop on traditional Series 200 mounting plates.

N.B. : Use POZIDRIVE No. 2 screwdrivers for all screws.

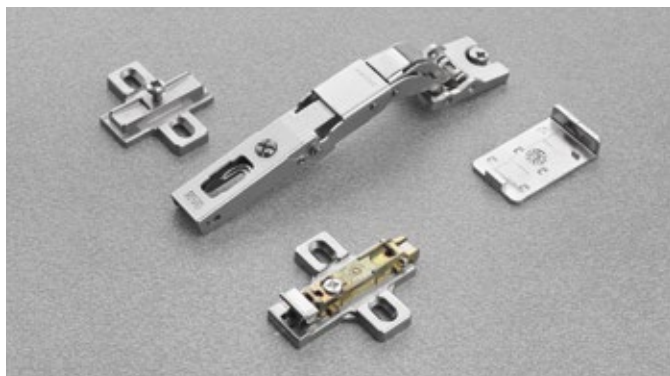

**Technical information**

**Push hinges are equipped with a special spring that acts to open the door independently of the release device.**

Hinge for glass doors. No drilling of the glass is required.  
Possible fixing inset distance on the door (K): from 0 to 22 mm.  
110° opening.  
Compatible with all traditional Series 200 mounting plates and with all Domi snap-on mounting plates.

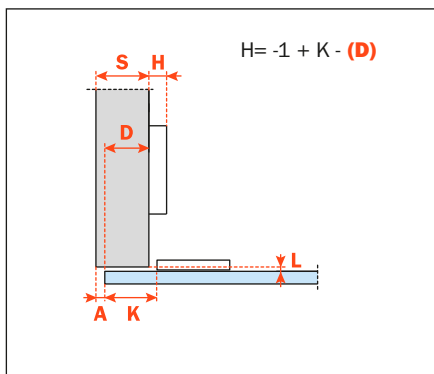
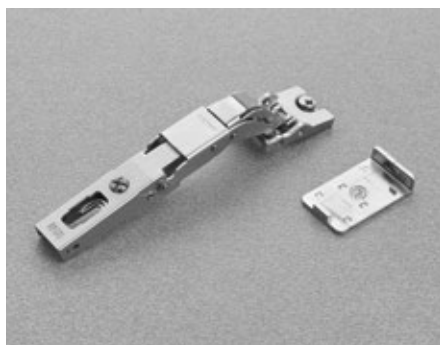

**CBGQA99**

**Packing**  
Boxes 150 pcs.  
Pallets 3.600 pcs.

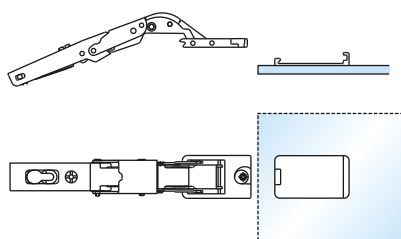

**1)** The hinge plate must be attached to the glass door or mirror by a special adhesive. We recommend that this operation is carried out by a specialist company. For further information on adhesives and their application, please contact the adhesive manufacturer or your glass supplier.

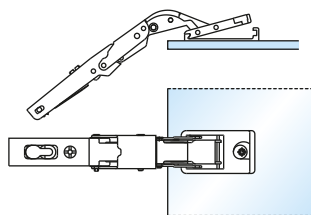

**2)** Fix the hinge when the plate is bonded to the glass.

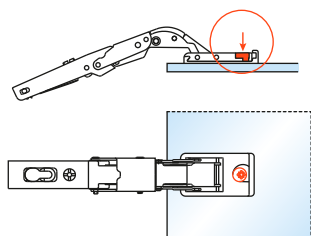

**3)** Locate the hinge cup onto the plate and rotate the cam.

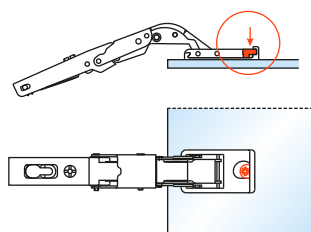

**4)** The hinge is now fixed to the door.

**“C” Value**

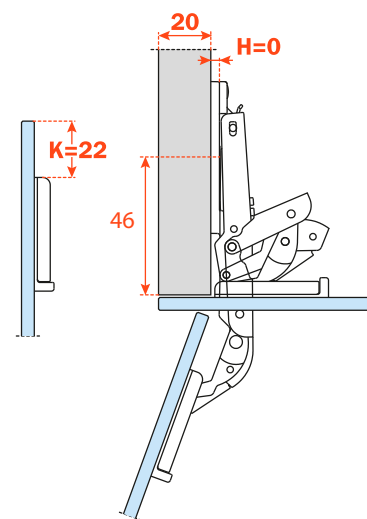

$K = 0 - 22$

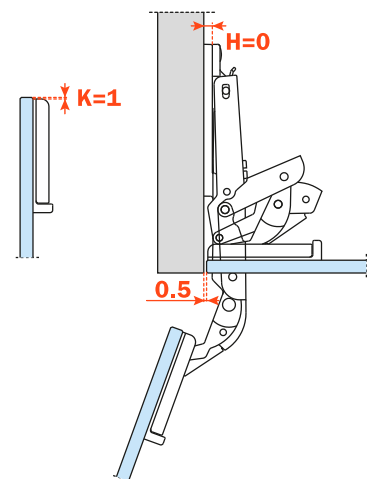

## Push - Series B hinges for wooden doors

### Technical features

Series B hinges can provide a solution to a number of special applications, which include half-inset doors and doors with moulded profiles.  
**Dimensions of the 35 mm cup.**  
**Bright nickel plated die-cast cup and arm.**

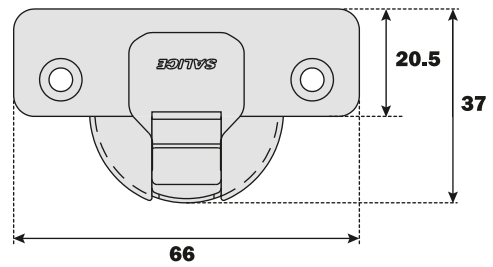

Constant "L" value of 0.7 mm (it does not change during side adjustment).

Approx. number of hinges required according to the door dimension and weight.

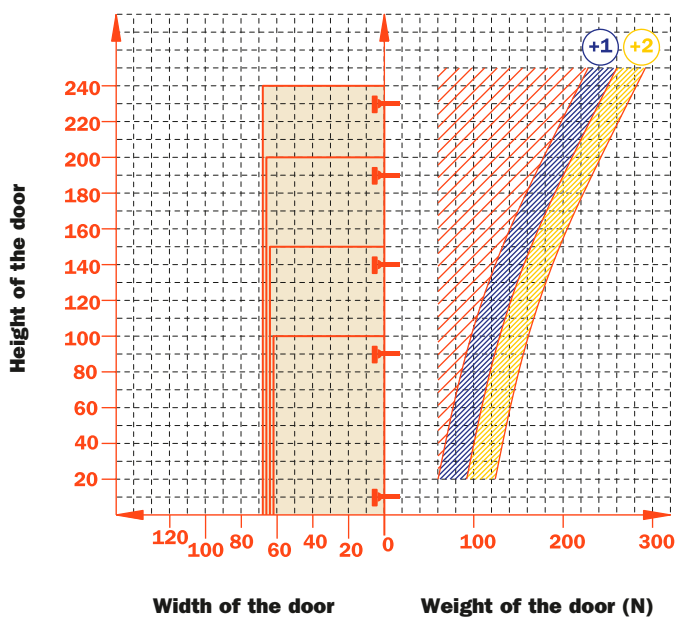

### Adjustments

Compensated side adjustment from -1.5 mm to +4.5 mm.  
 Height adjustment  $\pm 2$  mm.  
 Depth adjustment with Series 200 mounting plates +2.8 mm.  
 Depth adjustment with Domi snap-on mounting plates from -0.5 mm to +2.8 mm.  
 Anti-sliding safety stop.

### Mounting plates

Symmetrical and asymmetrical bright nickel plated steel or die-cast Series 200 mounting plates.  
 Snap-on assembly on Domi mounting plates.  
 Positioning with pre-determined stop on traditional Series 200 mounting plates.

N.B. : Use POZIDRIVE No. 2 screwdrivers for all screws.



	<p>48 6 110° 35 K</p>	<p>45 9.5 110° 35 K</p>	<p>52 5.5 110° 35 K</p>
<p>Wood screw</p>	<b>A</b>	<b>P</b>	<b>U</b>
	<p>48 6 110° 35 10 K</p>	<p>45 9.5 110° 35 8 K</p>	<p>52 5.5 110° 35 10 K</p>
<p>Dowel</p>	<b>B</b>	<b>R</b>	<b>W</b>

Use this table to identify the available drillings and fixings.  
 Fill the third position of the hinge code number with the letter or the number corresponding to your choice. I.e.: CB\_QA99.

↑  
Fill this position with the chosen letter or number.



## Technical information

Push hinges are equipped with a special spring that acts to open the door independently of the release device and can provide a solution to a number of special applications, which include half-inset doors and doors with moulded profiles.

9 mm deep metal cup.

110° opening.

Possible drilling distance on the door (K): from 3 to 18 mm.

Compatible with all traditional Series 200 mounting plates and with all Domi snap-on mounting plates.

## Space needed to open the door

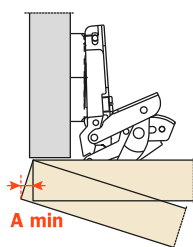

	T=	16	18	20	22	24	26
K=3	<b>A=</b>	0.0	0.0	0.0	0.0	0.3	1.4
K=4	<b>A=</b>	0.0	0.0	0.0	0.0	0.4	1.5
K=5	<b>A=</b>	0.0	0.0	0.0	0.0	0.5	1.9
K=6	<b>A=</b>	0.0	0.0	0.0	0.0	0.7	2.6
K=7	<b>A=</b>	0.0	0.0	0.0	0.0	11.3	12.8
K=8	<b>A=</b>	0.0	0.0	0.0	0.0	10.3	12.9
K=9	<b>A=</b>	0.0	0.0	0.0	0.0	9.3	11.9
K=10	<b>A=</b>	0.0	0.0	0.0	6.0	8.3	10.9
K=11	<b>A=</b>	0.0	0.0	0.0	5.1	7.3	9.9
K=12	<b>A=</b>	0.0	0.0	0.0	4.1	6.3	8.9
K=13	<b>A=</b>	0.0	0.0	1.4	3.3	5.3	7.9
K=14	<b>A=</b>	0.0	0.0	0.7	2.6	4.5	6.9
K=15	<b>A=</b>	0.0	0.0	0.2	2.0	3.8	5.9
K=16	<b>A=</b>	0.0	0.0	0.0	1.4	3.2	5.0
K=17	<b>A=</b>	0.0	0.0	0.0	1.0	2.7	4.4
K=18	<b>A=</b>	0.0	0.0	0.0	0.7	2.2	3.9

The above values are calculated on the assumption that the doors have square edges. They are reduced if the doors have radiussed edges.

## Projection of the door

Projection of the door from the cabinet side at the max. opening. The figures are based on a straight arm hinge, H=0 mm thickness of mounting plate and K value = 3 mm.

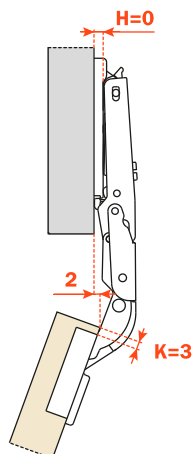

## "C" value

With this formula you can obtain the max. thickness of the moulded door that can be opened without touching adjacent carcase sides, doors or walls, whilst bearing in mind the above L-K-T values.

$$C = 5.5 + K + A$$

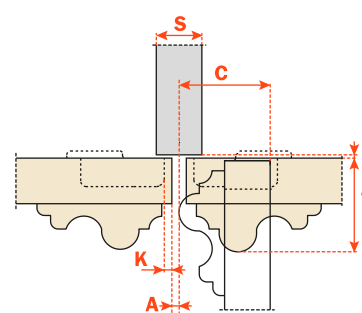
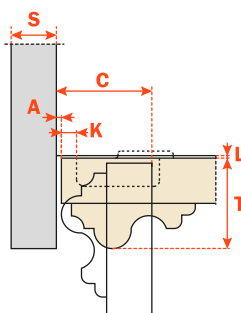

**Packing**

Boxes 150 pcs.  
Pallets 3.600 pcs.

Use these formulas to determine the type of hinge arm, the drilling distance "K" and the height of the mounting plate "H" which is necessary to solve each application problem.

To limit the opening of the hinge, see page 361 chapter "Accessories".

Use the tables "Drillings and fixings" at page 233 to complete the code number of the desired hinge.

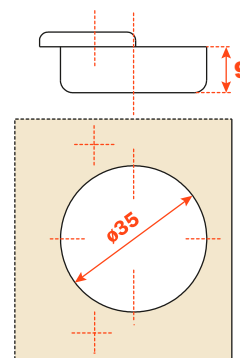

Arm 0

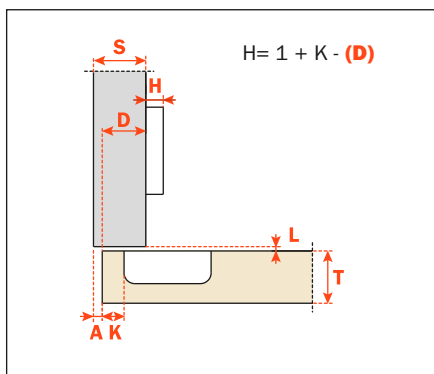
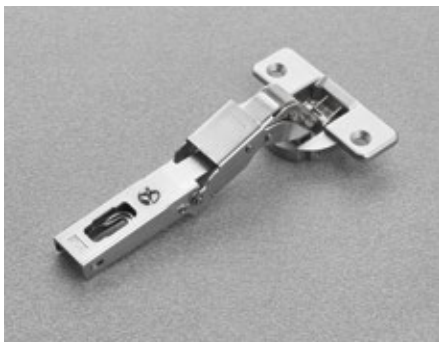

**CB\_QA99**



## Domi snap-on mounting plates



Domi snap-on mounting plates

# Domi snap-on mounting plates

- Domi snap-on mounting plates. For hinges Series 100, 200, 400, F, B, M and Silentia.
- 21+32 mm drilling.
- Depth and height adjustment by cam.

## Packing

Boxes 300 pcs.  
Pallets 7.200 pcs.

### BAP3R



Die-cast mounting plates.  
Fixing: wood screw.  
B 3.5 DIN 7983.

H= 0 1 2 3 4 5 6 9 12

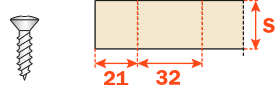

### BAPGR



Die-cast mounting plates.  
Fixing: Euroscrew.  
Drilling  $\varnothing 5 \times 11$ .

H= 0 1 2 3 4 5 6 9 12

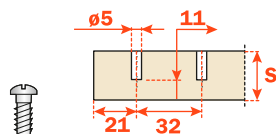

### BAPMR



Die-cast mounting plates.  
Fixing: expanding dowel.  
Drilling  $\varnothing 10 \times 11.5$  mm.

H= 0 1 2 3 4 5 6 9 12

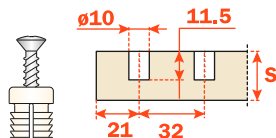

### BAP7R



Die-cast mounting plates.  
Fixing: knock-in dowel.  
Drilling  $\varnothing 10 \times 11.5$  mm.

H= 0 1 2 3 4 5 6 9 12

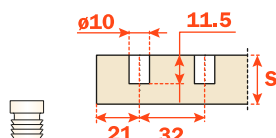



- Cruciform Domi snap-on mounting plates. For hinges Series 100, 200, 400, F, B, M and Silentia.
- 37x32 mm drilling.
- Depth and height adjustment by cam.

**Packing**

Boxes 300 pcs.  
Pallets 7.200 pcs.

**BAR3R**



Die-cast mounting plates.  
Fixing: wood screw.  
B 3.5 DIN 7983.

H= 0 1 2 3 4 5 6 9 12

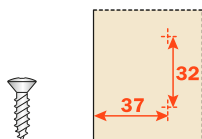

**BAR4R**



Die-cast mounting plates.  
Fixing: expanding dowel.  
Drilling  $\varnothing 5 \times 11$  mm.

H= 0 1 2 3 4 5 6 9 12

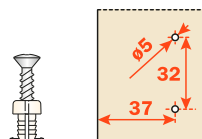

**BARMR**



Die-cast mounting plates.  
Fixing: expanding dowel.  
Drilling  $\varnothing 10 \times 11.5$  mm.

H= 0 1 2 3 4 5 6 9 12

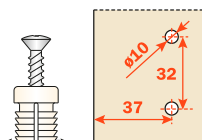

**BARGR**



Die-cast mounting plates.  
Fixing: Euro screw.  
Drilling  $\varnothing 5 \times 11$  mm.

H= 0 1 2 3 4 5 6 9 12

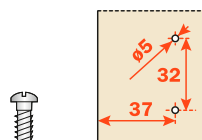

**BAR7R**



Die-cast mounting plates.  
Fixing: knock-in dowel.  
Drilling  $\varnothing 10 \times 11.5$  mm.

H= 0 1 2 3 4 5 6 9 12

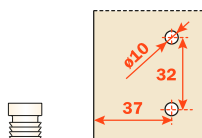

**BARGR**



Die-cast mounting plates.  
Fixing: Euro screw.  
Drilling  $\varnothing 5 \times 11$  mm.

H= 18 19 20 21 22 23 24 27 30

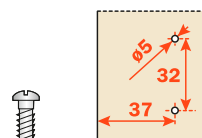

**BAR3L/F**



Steel mounting plates.  
Fixing: wood screw.  
B 4.2 DIN 7983

H= 0 2 3 4 6

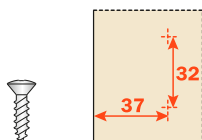

**BARGL/F**



Steel mounting plates.  
Fixing: Euro screw.  
Drilling  $\varnothing 5 \times 11$  mm.

H= 0 2 3 4 6

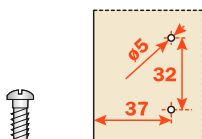

**BAR7L/F**



Steel mounting plates.  
Fixing: knock-in dowel.  
Drilling  $\varnothing 10 \times 11.5$  mm.

H= 0 2 3 4 6

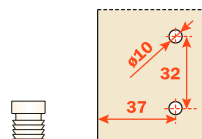

# Domi snap-on mounting plates

- Cruciform Domi snap-on mounting plates. For hinges Series 100, 200, 400, F, B, M and Silentia.
- 37x32 mm drilling.
- Depth adjustment by cam.

## Packing

Boxes 300 pcs.  
Pallets 7.200 pcs.

### BAV3M/F



Steel mounting plates.  
Fixing: wood screw.  
B 3.5 DIN 7983.

H= 0 2 3

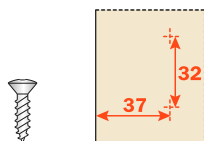

### BAV3E/F



Die-cast mounting plates.  
Fixing: wood screw.  
B 3.5 DIN 7983.

H= 4 6 9 12 18

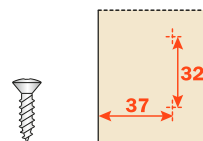

### BAVGM/F



Steel mounting plates.  
Fixing: Euroscrew.  
Drilling  $\varnothing 5 \times 11$  mm.

H= 0 2 3

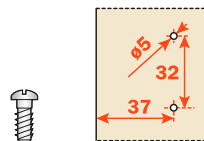

### BAVGE/F



Die-cast mounting plates.  
Fixing: Euroscrew.  
Drilling  $\varnothing 5 \times 11$  mm.

H= 4 6 9 12 18

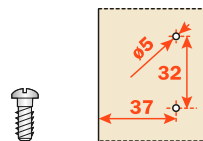

### BAV4M/F



Steel mounting plates.  
Fixing: expanding dowel.  
Drilling  $\varnothing 5 \times 7.5$  mm.

H= 0 2 3

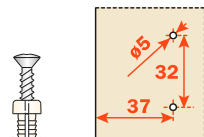

### BAV4E/F



Die-cast mounting plates.  
Fixing: expanding dowel.  
Drilling  $\varnothing 5 \times 7.5$  mm.

H= 4 6 9 12 18

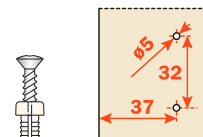

### BAV7M/F



Steel mounting plates.  
Fixing: knock-in dowel.  
Drilling  $\varnothing 10 \times 10$  mm.

H= 0 2 3

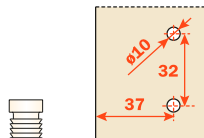

### BAV7E/F



Die-cast mounting plates.  
Fixing: knock-in dowel.  
Drilling  $\varnothing 10 \times 10$  mm.

H= 4 6 9 12 18

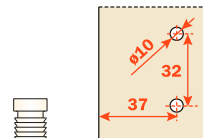

## Series 200 mounting plates with traditional assembly





# Series 200 mounting plates with traditional assembly

- Asymmetrical cruciform mounting plates. For hinges Series 100, 200, 400, 600, 900, F, B, M and Silentia.
- **For hinges series 800 use steel mounting plates only.**
- 28x32 mm drilling.
- Height adjustment  $\pm 2$  mm.

## Packing

Boxes 600 pcs.  
Pallets 14.400 pcs.

### B2S3H



Steel mounting plates.  
Fixing: wood screw.  
B 3.5 DIN 7983.

H= 0 1 2 3

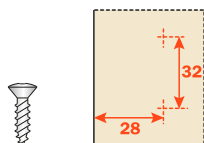

### B2S3B



Die-cast mounting plates.  
Fixing: wood screw.  
B 3.5 DIN 7983.

H= 6 9 12

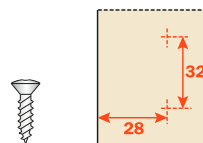

### B2SGH



Steel mounting plates.  
Fixing: Euroscrew.  
Drilling  $\varnothing 5 \times 11$  mm.

H= 0 1 2 3

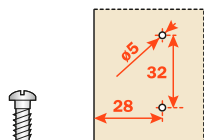

### B2SGB



Die-cast mounting plates.  
Fixing: Euroscrew.  
Drilling  $\varnothing 5 \times 11$  mm.

H= 6 9 12

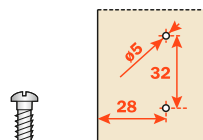

### B2S4H



Steel mounting plates.  
Fixing: expanding dowel.  
Drilling  $\varnothing 5 \times 7.5$  mm.

H= 0 1 2 3

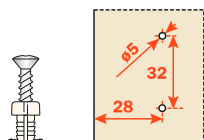

### B2S7H



Steel mounting plates.  
Fixing: knock-in dowel.  
Drilling  $\varnothing 10 \times 10$  mm.

H= 0 1 2 3

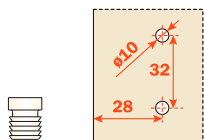

- Symmetrical cruciform mounting plates. For hinges Series 100, 200, 400, 600, 800, 900, F, B, M and Silentia.

- **For hinges series 800 use steel mounting plates only.**

- 37x32 mm drilling.

- Height adjustment  $\pm 2$  mm.

**ATTENTION!** Mounting plates with negative value can be used on D-G-P arms only.

**Packing**

Boxes 600 pcs.

Pallets 14.400 pcs.

**B2V3H**



Steel mounting plates.  
Fixing: wood screw.  
B 3.5 DIN 7983.

H= -2 0 2 3 4 6 9

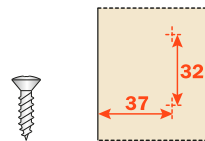

**B2V3B**



Die-cast mounting plates.  
Fixing: wood screw.  
B 3.5 DIN 7983.

H= 12 18

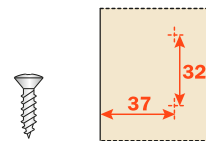

**B2VGH**



Steel mounting plates.  
Fixing: Euroscrew.  
Drilling  $\varnothing 5 \times 11$  mm.

H= -2 0 2 3 4 6 9

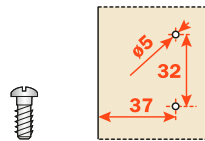

**B2VGB**



Die-cast mounting plates.  
Fixing: Euroscrew.  
Drilling  $\varnothing 5 \times 11$  mm.

H= 12 18

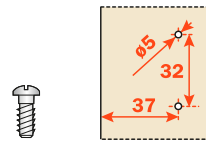

**B2V4H**



Steel mounting plates.  
Fixing: expanding dowel.  
Drilling  $\varnothing 5 \times 7.5$  mm.

H= 0 2 3 4 6 9

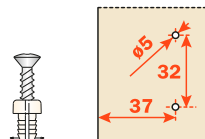

**B2V4B**



Die-cast mounting plates.  
Fixing: expanding dowel.  
Drilling  $\varnothing 5 \times 7.5$  mm.

H= 12 18

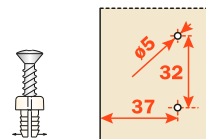

**B2V7H**



Steel mounting plates.  
Fixing: knock-in dowel.  
Drilling  $\varnothing 10 \times 10$  mm.

H= 0 2 3 4 6 9

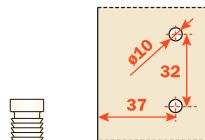

**B2V7B**



Die-cast mounting plates.  
Fixing: knock-in dowel.  
Drilling  $\varnothing 10 \times 10$  mm.

H= 12 18

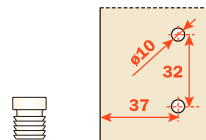

# Series 200 mounting plates with traditional assembly

- For hinges Series 100, 200, 400, 600, 900, F, B, M and Silentia.
- Straight and cruciform mounting plates.
- Height adjustment  $\pm 2$  mm by cam.

**Packing:** heights 0, 2, 3 and 4  
Boxes 600 pcs.  
Pallets 14.400 pcs.

**Packing:** heights 6 and 9  
Boxes 300 pcs.  
Pallets 7.200 pcs.

## B2P7E



Die-cast mounting plates.  
Fixing: knock-in dowel.  
Drilling  $\varnothing 10 \times 11.5$ .

H= 0 2 3

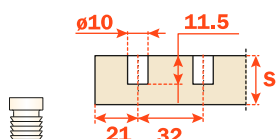

## B2R3E



Die-cast mounting plates.  
Fixing: wood screw.  
B 3.5 DIN 7983.

H= 0 2 3 4 6 9

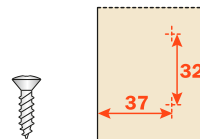

## B2RGE



Die-cast mounting plates.  
Fixing: Euroscrew.  
Drilling  $\varnothing 5 \times 11$  mm.

H= 0 2 3 4 6 9

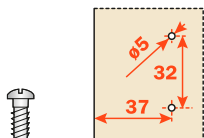

## B2R7E



Die-cast mounting plates.  
Fixing: knock-in dowel.  
Drilling  $\varnothing 10 \times 11.5$  mm.

H= 0 2 3 4 6 9

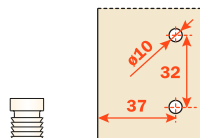

- For hinges Series 100, 200, 400, 600, 900, F, B and Silentia.
- Variable die-cast mounting plates for angled assembly from  $-7.5^\circ$  to  $+7.5^\circ$  and intermediate degrees, for special assemblies.
- An almost infinite variety of angle door applications is possible using variable-angle mounting plates in conjunction with one of Salice's range of angled-arm hinges.

### Packing

Boxes 600 pcs.  
Pallets 14.400 pcs.

## B2V3BW9R



Die-cast mounting plates.  
Fixing: wood screw.  
B 3.5 DIN 7983.

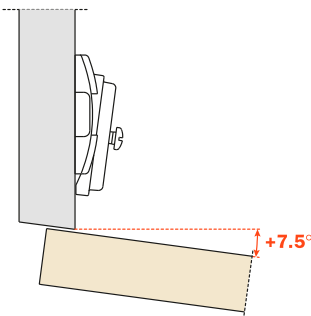

## B2VGBW9R



Die-cast mounting plates.  
Fixing: Euroscrew.  
Drilling  $\varnothing 5 \times 11$  mm.

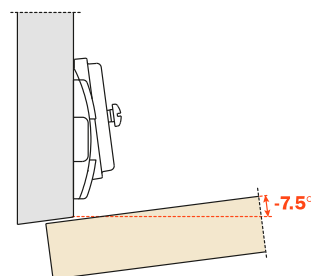

- For hinges Series 100, 200, 400, 600, 900, F, B and Silentia.
- Variable die-cast mounting plates for angled assembly from +10° to +30° and intermediate degrees, for special assemblies.
- An almost infinite variety of angle door applications is possible using variable-angle mounting plates in conjunction with one of Salice's range of angled-arm hinges.

**Packing**

Boxes 300 pcs.  
Pallets 7.200 pcs.

**B2V3BW9S**



Die-cast mounting plates.  
Fixing: wood screw.  
B 3.5 DIN 7983.

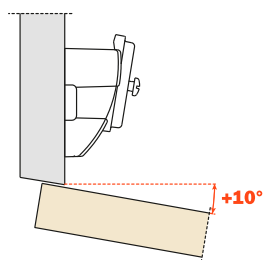

**B2VGBW9S**



Die-cast mounting plates.  
Fixing: Euroscrew.  
Drilling ø5x11 mm.

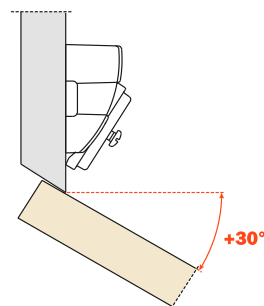

- Die-cast angled mounting plates for assembly at 15°. For hinges Series 100, 200, 400, 600, 900, F, B and Silentia.

**Packing**

Boxes 600 pcs.  
Pallets 14.400 pcs.

**B2V3BW9**



Die-cast mounting plates.  
Fixing: wood screw.  
B 3.5 DIN 7983.

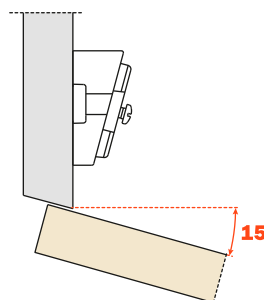
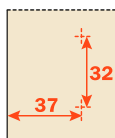

**B2VGBW9**



Die-cast mounting plates.  
Fixing: Euroscrew.  
Drilling ø5x11 mm.

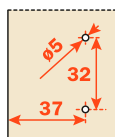



## Series 200 mounting plates with traditional assembly

- Die-cast mounting plates for special assemblies. For hinges Series 100, 200, 400, 600, 900, F, B and Silentia.
- An almost infinite variety of angle door applications is possible using variable-angle mounting plates in conjunction with one of Salice's range of angled-arm hinges; from  $-45^{\circ}$  to  $+70^{\circ}$ .

### Variable-angle mounting plates for angled assembly from $+7.5^{\circ}$ to $-7.5^{\circ}$ and intermediate angles by adjusting the set screw indicated.

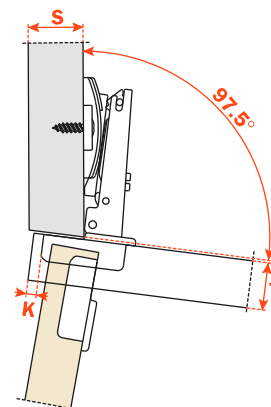
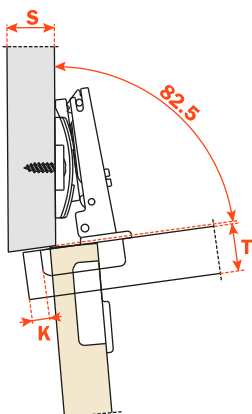
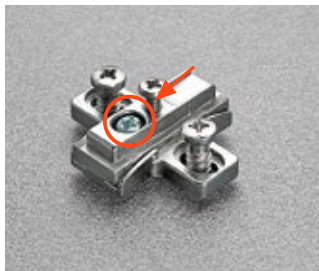

Assembly example from  $82.5^{\circ}$  to  $97.5^{\circ}$  angle.

### Angled mounting plates for assembly at $15^{\circ}$ .

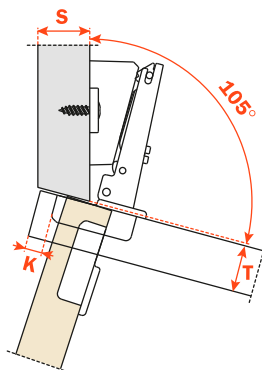

Assembly example with a  $105^{\circ}$  angle.

### Variable-angle mounting plate for angled assembly from $+10^{\circ}$ to $+30^{\circ}$ and intermediate angles by adjusting the set screw indicated.

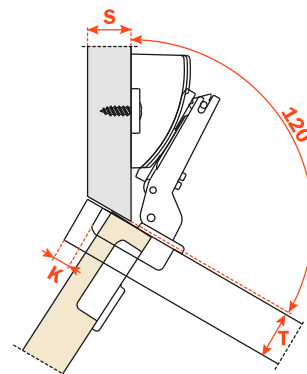
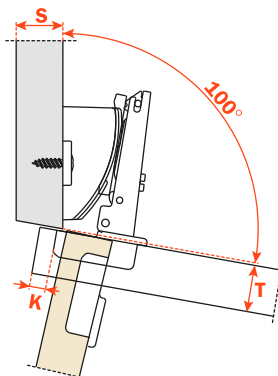

Assembly example from  $100^{\circ}$  to  $120^{\circ}$  angle.

## Variable-angle adapters

Die-cast adapters for all mounting plates.

### SAV354X9R



Die-cast adapter +5°. Fixing: wood screw.  
B 3.5 DIN 7983.

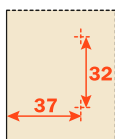

### SAV354X9S



Die-cast adapter +10°. Fixing: wood screw.  
B 3.5 DIN 7983.

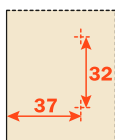



## Series 300 mounting plates



## Series 300 mounting plates

- Asymmetrical cruciform mounting plates. For hinges Series 300.
- 20x32 mm drilling.
- Height adjustment  $\pm 1,5$  mm by cam.

### Packing mounting plates

Boxes 600 pcs.  
Pallets 14.400 pcs.

### Packing spacers for mounting plates

Boxes 300 pcs.  
Pallets 7.200 pcs.

#### B383E09



Steel mounting plates.  
Fixing: wood screw.  
B 3.5 DIN 7983.

H= 0

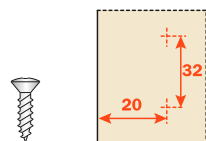

#### B383E69



Steel mounting plates.  
Fixing: wood screw.  
B 3.5 DIN 7983.

H= 6

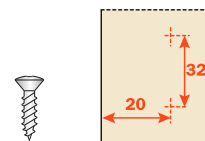

#### S38X8639



3 mm spacer for special applications.

#### S38X86D9



13 mm spacer for special applications.

# Smove





Smove is the innovative system used to soften the closing action of any door.

It can be installed to all cabinet applications and offers optimal performance.



## D0S\_SNG - Smoveholder



We suggest that one Smoveholder only is used for each door, by selecting one of the three available models:



### D0S7SNG

to be used with **doors made with particularly light materials.**



### D0S8SNG

to be used with **doors with two hinges.**



### D0S9SNG

to be used with **doors with more than two hinges.**

#### Packing

Boxes 300 pcs  
Pallets 7.200 pcs

## Adapter for hinges with arm 0



Adapter to be used ONLY with cruciform mounting plates 37x 32 mm.  
For use with mounting plates to be fixed with wood screw, please use a screw with screwhead  $\varnothing$  8 mm and length 16 mm.  
It is suggested the use of the article V234X164.

**D2VX09** - for steel mounting plates

**DARX09** - for die-cast mounting plates

#### Packing

Boxes 300 pcs  
Pallets 7.200 pcs

## Adapter for hinges with arm 5



Adapter to be used ONLY with cruciform mounting plates 37x 32 mm.  
For use with mounting plates to be fixed with wood screw, please use a screw with screwhead  $\varnothing$  8 mm and length 16 mm.  
It is suggested the use of the article V234X164.

**D2VX59** - for steel mounting plates

**DARX59** - for die-cast mounting plates

#### Packing

Boxes 300 pcs  
Pallets 7.200 pcs

## Adapter for hinges with arm 9



Adapter to be used ONLY with cruciform mounting plates 37x 32 mm.  
For use with mounting plates to be fixed with wood screw, please use a screw with screwhead  $\varnothing$  8 mm and length 16 mm.  
It is suggested the use of the article V234X164.

**D2VX99** - for steel mounting plates

**DARX99** - for die-cast mounting plates

#### Packing

Boxes 300 pcs  
Pallets 7.200 pcs

## Adapter for hinges with arm 17



Adapter to be used ONLY with cruciform mounting plates 37x 32 mm.  
For use with mounting plates to be fixed with wood screw, please use a screw with screwhead  $\varnothing$  8 mm and length 16 mm.  
It is suggested the use of the article V234X164.

**D2VXP9** - for steel mounting plates

**DARXP9** - for die-cast mounting plates

#### Packing

Boxes 150 pcs  
Pallets 3.600 pcs

# Smove - DOS\_SNG - Choice of the adapter

Smove works by bearing against the flange of the hinge cup and for this reason it is necessary to choose the appropriate adapter. By reducing the door overlay, it is necessary consequently to increase the height of the adapter.

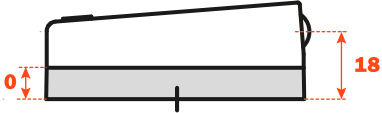
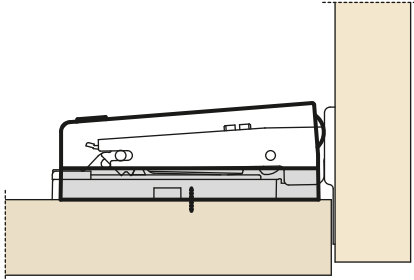
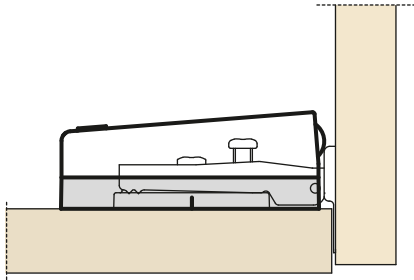
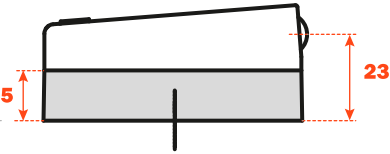
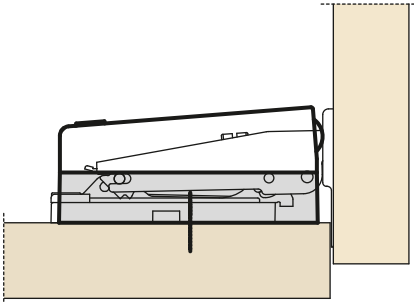
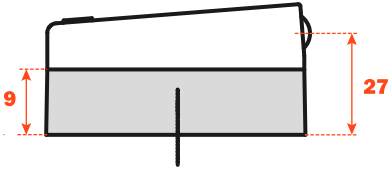
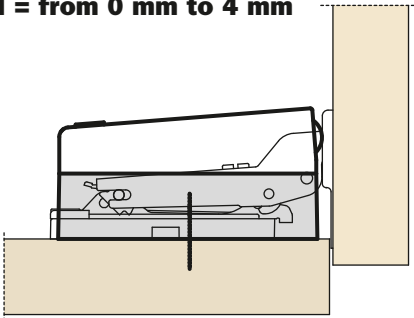
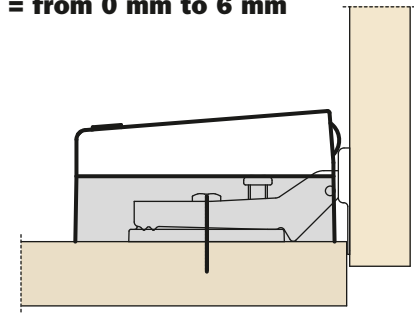
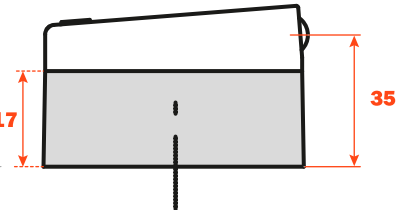
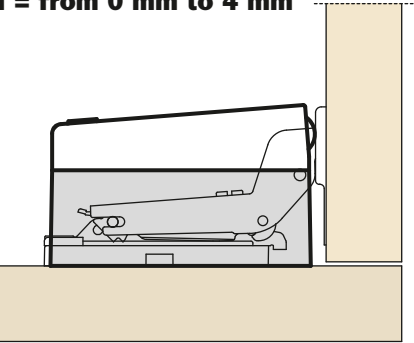
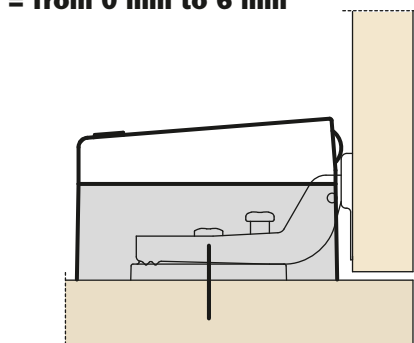
	FOR HINGES SERIES 100, 200, 800 AND 900	FOR HINGES SERIES 400 AND 600
<b>ADAPTER HEIGHT = 0</b> 	<b>For mounting plates H = from 0 mm to 4 mm</b> 	<b>For mounting plates H = from 0 mm to 6 mm</b> 
<b>ADAPTER HEIGHT = 5</b> 	<b>For mounting plates H = from 0 mm to 4 mm</b> 	
<b>ADAPTER HEIGHT = 9</b> 	<b>For mounting plates H = from 0 mm to 4 mm</b> 	<b>For mounting plates H = from 0 mm to 6 mm</b> 
<b>ADAPTER HEIGHT = 17</b> 	<b>For mounting plates H = from 0 mm to 4 mm</b> 	<b>For mounting plates H = from 0 mm to 6 mm</b> 

**FOR HINGES SERIES F**

**FOR HINGES SERIES B**

The required overlay can be achieved not only by using the appropriate hinge arm, but also by using mounting plates of different heights.

Application examples:

**For mounting plates  
H = from 0 mm to 3 mm**

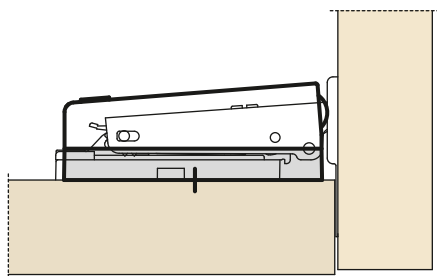

**Arm 0  
For mounting plates  
H = from 6 mm to 9 mm**

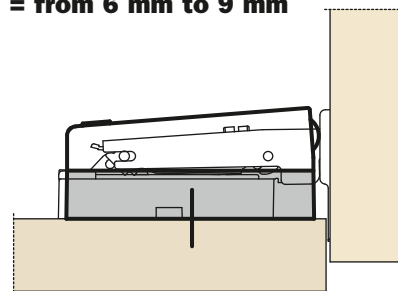

**For mounting plates  
H = from 0 mm to 3 mm**

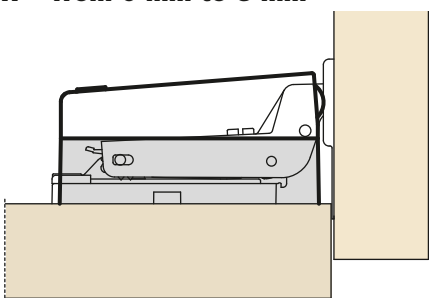

**For mounting plates  
H = from 0 mm to 4 mm**

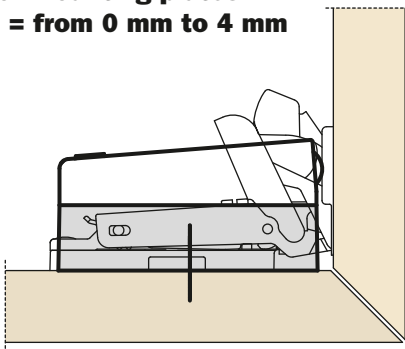

**Arm 0  
For mounting plates  
H = from 9 mm to 12 mm**

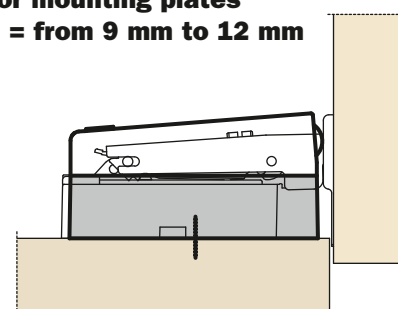

**For mounting plates  
H = 0 mm**

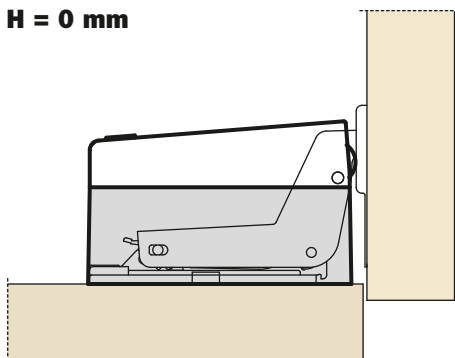

**Arm 0  
For mounting plates  
H = 18 mm**

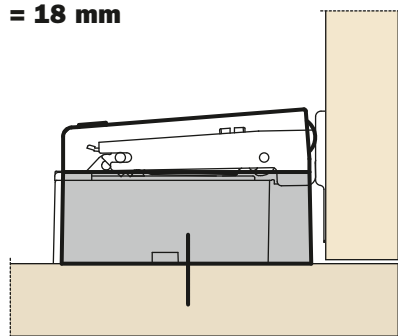

**1** - Loosen one of the two fixing screws of the mounting plate.

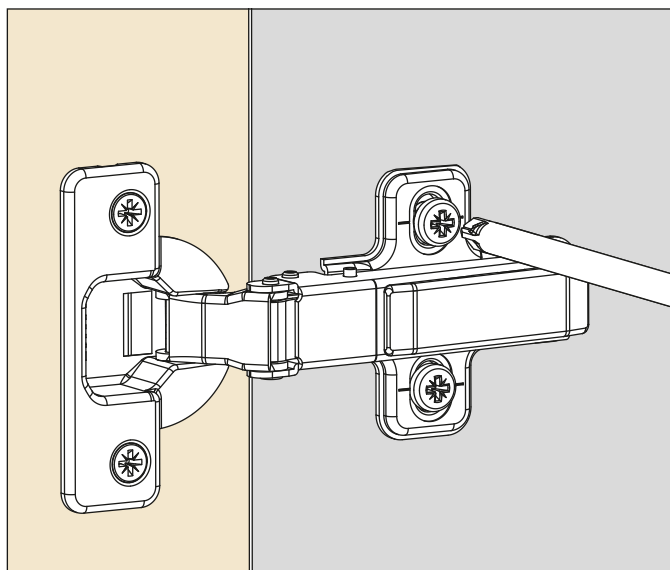

**2** - Insert the adapter for the Smoveholder.

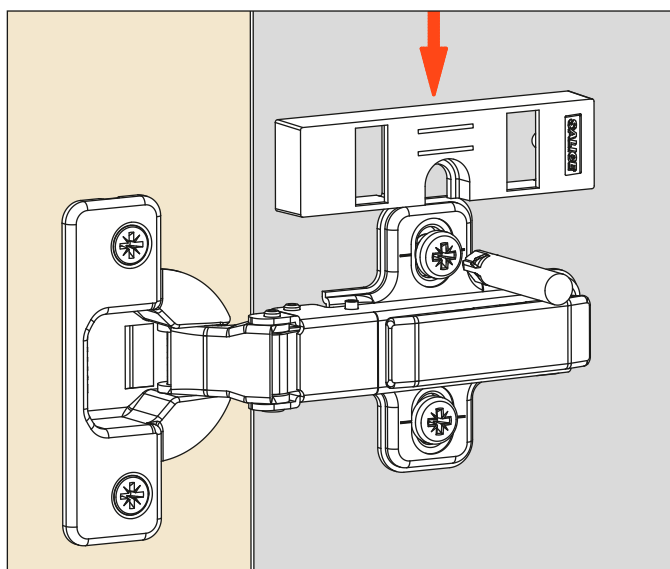

**3** - Retighten the fixing screw of the mounting plate.

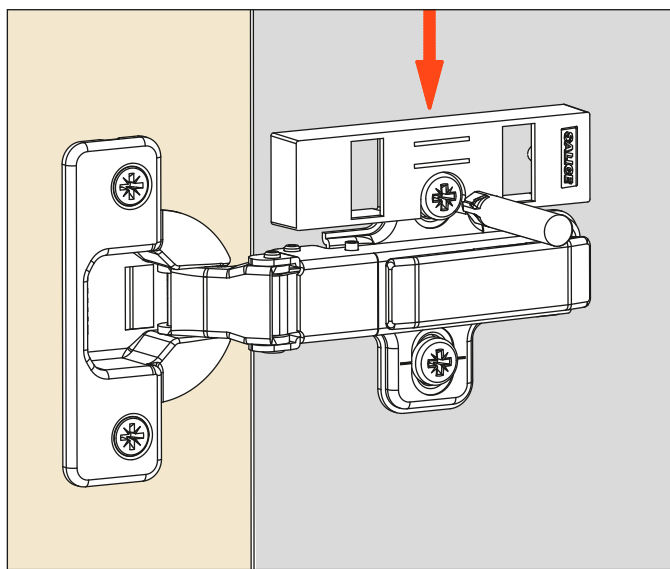



4 - Apply the Smoveholder to the adapter, as indicated.

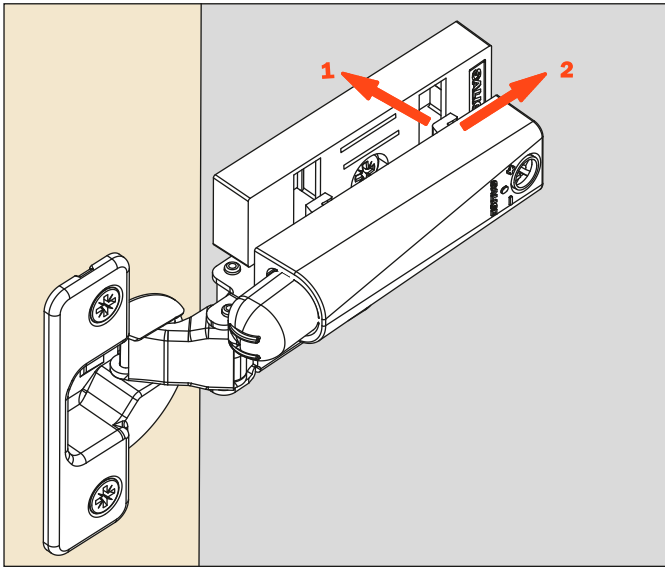

5 - Finally it is possible to adjust the Smove to increase or reduce the decelerating effect.

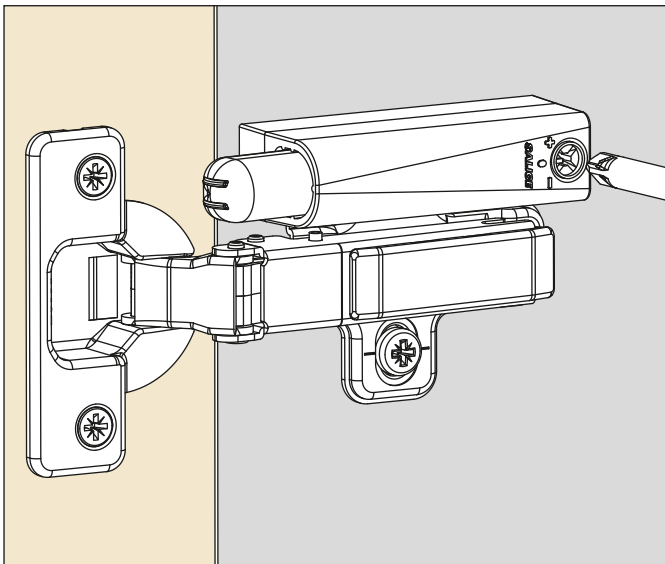

### Positive adjustment

Rotating the screw towards the + sign, thus moving the Smove forward, the decelerating effect increases.

### Negative adjustment

Rotating the screw towards the - sign, thus moving the Smove backwards, the decelerating effect reduces.







**DOL\_SNG - Smoveholder with assembly stop devices**



We suggest that one smoveholder only is used for each door, by selecting one of the three available models:



**DOL7SNG**  
to be used with **doors made with particularly light materials.**



**DOL8SNG**  
to be used with **doors with two hinges.**



**DOL9SNG**  
to be used with **doors with more than two hinges.**

**Packing**  
Boxes 150 pcs  
Pallets 13.500 pcs

**DOL\_SNGR - Smoveholder without assembly stop devices**



We suggest that one smoveholder only is used for each door, by selecting one of the three available models:



**DOL7SNGR**  
to be used with **doors made with particularly light materials.**



**DOL8SNGR**  
to be used with **doors with two hinges.**



**DOL9SNGR**  
to be used with **doors with more than two hinges.**

**Packing**  
Boxes 150 pcs  
Pallets 13.500 pcs

**Smoveholder application**

**Arm 0, Arm 5, Arm 9 - Smoveholder DOL\_SNG**

Frontal positioning: with assembly stop devices.

Side positioning: place the smoveholder with its wing in contact with the side of the cabinet.

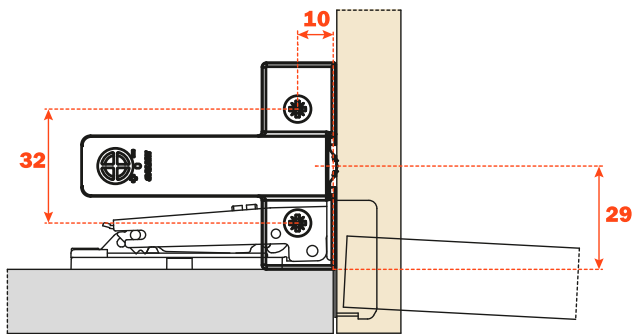

**Arm 17 - Smoveholder DOL\_SNGR**

Frontal positioning: drilling value at + 11 mm plus the door thickness.

Side positioning: place the smoveholder with its centreline approx. 5 mm from the edge of the door at its fully open position.

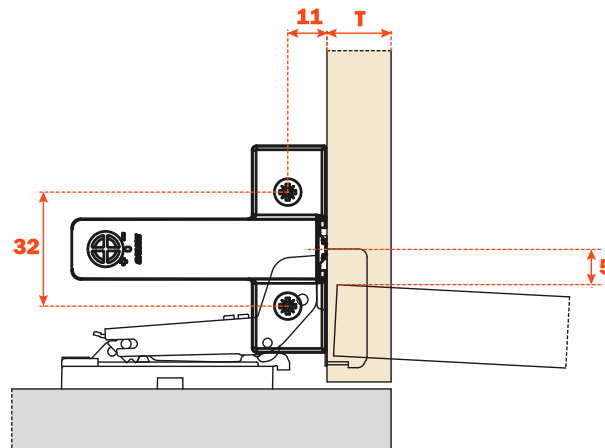

1 - Place the smoveholder in position on the top or bottom panel with its wing in contact with the side of the cabinet.

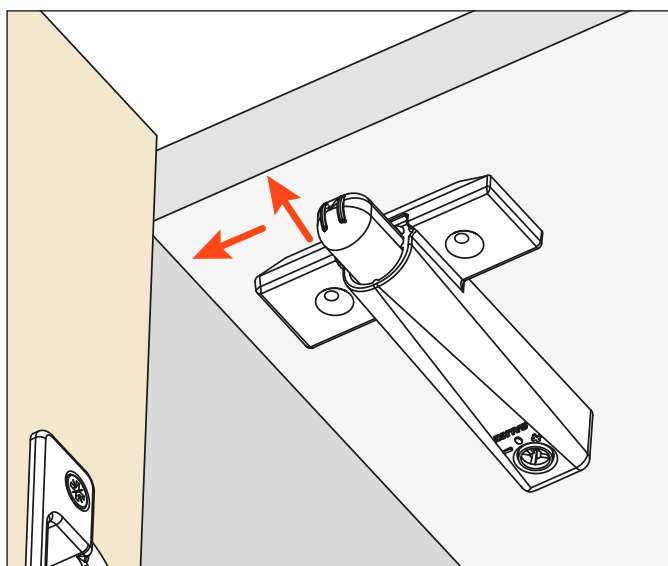

2 - Screw the smoveholder into position.

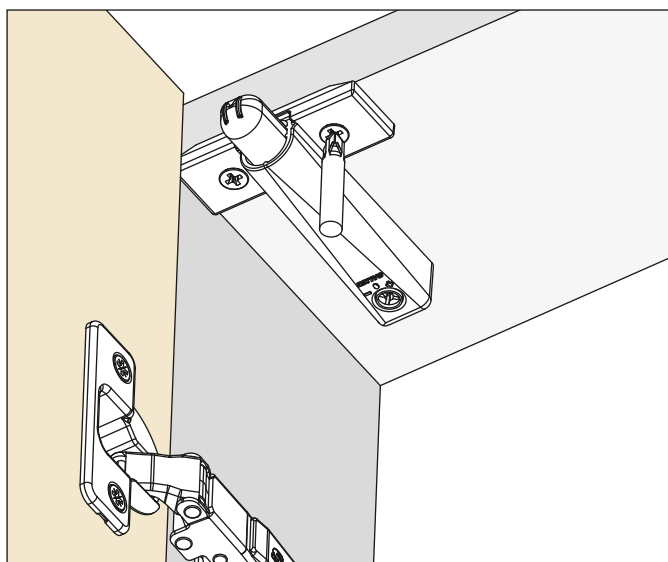

3 - Finally it is possible to adjust the Smove to increase or reduce the decelerating effect.

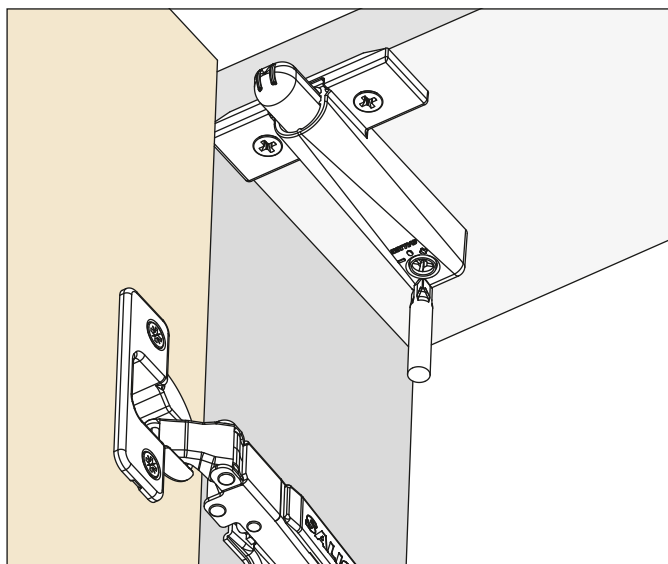

### Positive adjustment

Rotating the screw towards the + sign, thus moving the Smove forward, the decelerating effect increases.



### Negative adjustment

Rotating the screw towards the - sign, thus moving the Smove backwards, the decelerating effect reduces.



## D005SNG



Smove

### Packing

Boxes 250 pcs.  
Cartons 2.000 pcs.

## D005SNB



Smove

### Packing

Boxes 250 pcs.  
Cartons 2.000 pcs.

### Technical information about the installation of SMOVE D005SN to be recessed

Insert Smove D005 into the cabinet side opposite the hinges. For an optimal performance, we suggest that Smove D005 is positioned at the centre of the side panel.

It is suggested for doors from 450 mm to 600 mm width.

For wood-based and alu-framed doors over 1600 mm height, it may be necessary to use two Smove, one to be inserted into the upper part and the second into the lower part of the cabinet side opposite the hinges.





## D006SNG



Smove

### Packing

Boxes 250 pcs.  
Cartons 2.000 pcs.

## D006SNB



Smove

### Packing

Boxes 250 pcs.  
Cartons 2.000 pcs.

## Technical information about the installation of SMOVE D006SN to be recessed

Insert Smove D006 at the centre of the top or the base panel of the cabinet.

For wood-based and alu-framed doors over 1600 mm height, it may be necessary to use two Smove, one to be inserted into the top and the second into the base panel of the cabinet.





## D008SNG



Smove

### Packing

Boxes 250 pcs.  
Cartons 2.000 pcs.

## D008SNB



Smove

### Packing

Boxes 250 pcs.  
Cartons 2.000 pcs.

## Technical information about the installation of SMOVE D008SN to be recessed

Insert Smove D008 into the top or the base panel of the cabinet on the hinged side.

A drilling distance of 27 mm from the cabinet side is suggested.

For doors over 1600 mm height, it may be necessary to use two Smove, one to be inserted into the top and the second into the base panel of the cabinet.



## D009SNG



Smove

### Packing

Boxes 250 pcs.  
Cartons 2.000 pcs.

## D009SNB



Smove

### Packing

Boxes 250 pcs.  
Cartons 2.000 pcs.

## Technical information about the installation of SMOVE D009SN to be recessed

Insert Smove D009 into the base panel of the cabinet on the hinged side.

Smove D009 is used for doors between 720 mm and 1600 mm high.

Drilling distance from the cabinet side:

- for hinges with **arm 0** mm the drilling distance equals **15 mm** plus the base height;
- for hinges with **arm 5** mm the drilling distance equals **20 mm** plus the base height;
- for hinges with **arm 9** mm the drilling distance equals **24 mm** plus the base height.



## D010SNG



Smove

### Packing

Boxes 250 pcs.  
Cartons 2.000 pcs.

## D010SNB



Smove

### Packing

Boxes 250 pcs.  
Cartons 2.000 pcs.

### Technical information about the installation of SMOVE D010SN to be recessed

Insert Smove D010 into the base panel of the cabinet on the hinged side.

Smove D010 is used for doors over 1600 mm high.

Drilling distance from the cabinet side:

- for hinges with **arm 0** mm the drilling distance equals **15 mm** plus the base height;

- for hinges with **arm 5** mm the drilling distance equals **20 mm** plus the base height;

- for hinges with **arm 9** mm the drilling distance equals **24 mm** plus the base height.



## To be recessed - Assembly instructions

Drill a hole  $\varnothing$  10 mm and min. 50 mm depth in the cabinet.  
Insert Smove into the hole.





## **Technical information about the installation of SMOVE with adapter**



**SMOVE D005** can be fitted using:

- 1) adapters to be screw-fixed to the cabinet side (see pages 269 and 270);
- 2) adapters with double sided adhesive system (see page 272).

It is suggested for doors from 450 mm to 600 mm width.

For wood-based and alu-framed doors over 1600 mm height, it may be necessary to use two Smove, one to be fixed to the upper part and the second to the lower part of the cabinet side opposite the hinges.

**SMOVE D006** can be fitted using:

- 1) adapters to be screw-fixed to the top or bottom panel of the cabinet (see pages 269 and 270);
- 2) adapters with double sided adhesive system (see page 272).

For wood-based and alu-framed doors over 1600 mm height, it may be necessary to use two Smove, one to be fixed to the top and the second to the base panel of the cabinet.



**SMOVE D008** can be fitted using:

- 1) adapters to be screw-fixed to the top or bottom panel of the cabinet (see pages 269 and 270); Smove should be positioned at a distance of 27 mm from the inside face of the cabinet side. If using cruciform adapters, the correct position is located by moving the adapters so that one wing is in contact with the inside face of the cabinet.
- 2) adapters with double sided adhesive system (see page 272).

For doors over 1600 mm height, it may be necessary to use two Smove, one to be fixed to the top and the second to the base panel of the cabinet.

- 3) adapters to be screw-fixed to the inside of the cabinet door (see page 274).

**D008** is used for doors up to 720 mm high.



**SMOVE D009 and D010** can be fitted using:

- 1) longitudinal adapters to be screw-fixed to the base panel of the cabinet (see pages 269 and 270);
- 2) adapters to be screw-fixed to the inside of the cabinet door (see page 274).

**D009** is used for doors between 720 mm and 1600 mm high.

**D010** is used for doors over 1600 mm high.

## Adapters to be screw fixed to the cabinet

### D063SNXR

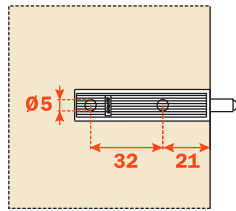
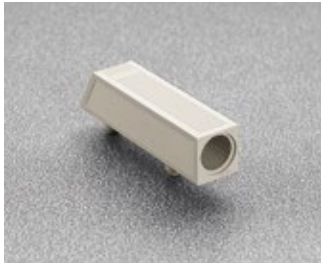

**D063SNGR** = grey  
**D063SNBR** = beige

Longitudinal plastic adapter.  
To be fixed with dowels.  
Without assembly stop device.

**Packing**  
Boxes 500 pcs.  
Pallets 12.000 pcs.

### D064SNXN

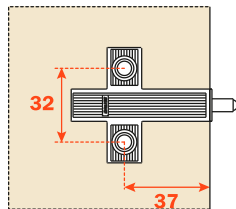

**D064SNGN** = grey  
**D064SNBN** = beige

Cruciform plastic adapter.  
To be fixed with wood screws.  
37x32 mm drilling.  
With assembly stop device.

**Packing**  
Boxes 500 pcs.  
Pallets 12.000 pcs.

### D064SNXR

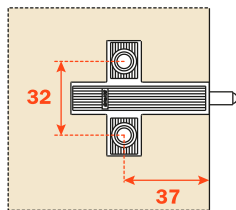

**D064SNGR** = grey  
**D064SNBR** = beige

Cruciform plastic adapter.  
To be fixed with wood screws.  
37x32 mm drilling.  
Without assembly stop device.

**Packing**  
Boxes 500 pcs.  
Pallets 12.000 pcs.

**D065SNGR** = grey - to be fixed with Euro screws.  
**D065SNBR** = beige - to be fixed with Euro screws.

### D060SNXN

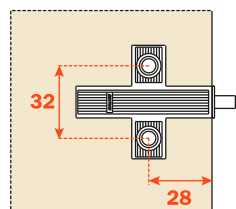

**D060SNGN** = grey  
**D060SNBN** = beige

Cruciform plastic adapter.  
To be fixed with wood screws.  
28x32 mm drilling.  
With assembly stop device.

**Packing**  
Boxes 500 pcs.  
Pallets 12.000 pcs.

### D060SNXR

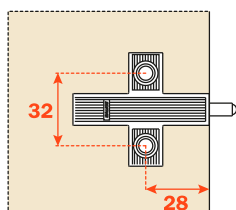

**D060SNGR** = grey  
**D060SNBR** = beige

Cruciform plastic adapter.  
To be fixed with wood screws.  
28x32 mm drilling.  
Without assembly stop device.

**Packing**  
Boxes 500 pcs.  
Pallets 12.000 pcs.

### D066SNXN

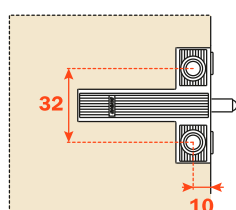

**D066SNGN** = grey  
**D066SNBN** = beige

Cruciform plastic adapter.  
To be fixed with wood screws.  
10x32 mm drilling.  
With assembly stop device.

**Packing**  
Boxes 500 pcs.  
Pallets 12.000 pcs.



## SMOVE - Adapters to be screw fixed to the cabinet

### D070SNXN

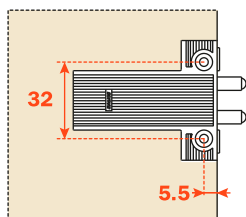

**D070SNGN** = grey  
**D070SNBN** = beige

Double cruciform plastic.  
To be fixed with wood screws.  
5.5x32 mm drilling.  
With assembly stop device.

**Packing**  
Boxes 500 pcs.  
Pallets 12.000 pcs.

### D070SNXR

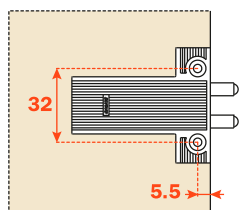

**D070SNGR** = grey  
**D070SNBR** = beige

Double cruciform plastic.  
To be fixed with wood screws.  
5.5x32 mm drilling.  
Without assembly stop device.

**Packing**  
Boxes 500 pcs.  
Pallets 12.000 pcs.

### D076XX9R

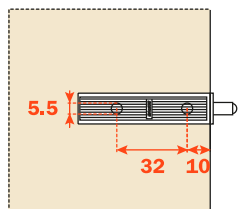

Longitudinal die-cast adapter.  
To be fixed with wood screws.  
Without assembly stop device.

**Packing**  
Boxes 500 pcs.  
Pallets 12.000 pcs.

Cover caps to be ordered separately.

**D077XX9R** - to be fixed with Euro screws.

### D076SN9

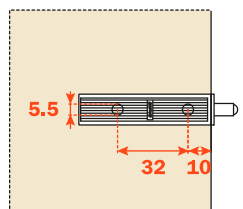

Longitudinal die-cast adapter.  
To be fixed with wood screws.  
With assembly stop device.

**Packing**  
Boxes 500 pcs.  
Pallets 12.000 pcs.

Cover caps to be ordered separately.

**D077SN9** - to be fixed with Euro screws.

**Adapter with assembly stop device**

Insert Smove into the adapter. Place the adapter in the position in the cabinet appropriate to the version of Smove to be installed, using the assembly stop device for final positioning.



**Adapter without assembly stop device**

Insert Smove into the adapter. Place the adapter in the position in the cabinet appropriate to the version of Smove to be installed, based on the dimensions indicated for the type of adapter.



### D051SNX



**D051SNG** = grey  
**D051SNB** = beige

Longitudinal plastic.  
With assembly stop device.

**Packing**  
Boxes 500 pcs.  
Pallets 12.000 pcs.

### D086SNX



**D086SNG** = grey  
**D086SNB** = beige

Longitudinal plastic with  
additional fixing screw.  
To be fixed with double sided  
adhesive system.  
It is suggested to fix the adapter  
with the included screw.  
For application with full  
overlay door.  
With assembly stop device

**Packing**  
Boxes 500 pcs.  
Pallets 12.000 pcs.

### D087SNX



**D087SNG** = grey  
**D087SNB** = beige

Longitudinal plastic with  
additional fixing screw.  
To be fixed with double sided  
adhesive system.  
It is suggested to fix the adapter  
with the included screw.  
For application with full and half  
overlay door.  
With assembly stop device.

**Packing**  
Boxes 500 pcs.  
Pallets 12.000 pcs.

## With adapter to be fixed with double sided adhesive system - Assembly instructions

For a correct application and to ensure optimal endurance, we suggest these guidelines are followed:

- 1) clean and de-grease the cabinet surface where the adapter is to be installed using an acetone based cleaner;
- 2) remove the protective strip from the adhesive;
- 3) place the adapter in position and apply a firm pressure for about one minute;
- 4) insert Smove frontally into the adapter;
- 5) allow a period of 12 hours to elapse before subjecting the product to continuous usage.

As an option for additional security, the adapters D086SNX and D087SNX can be fixed with the included wood screw.

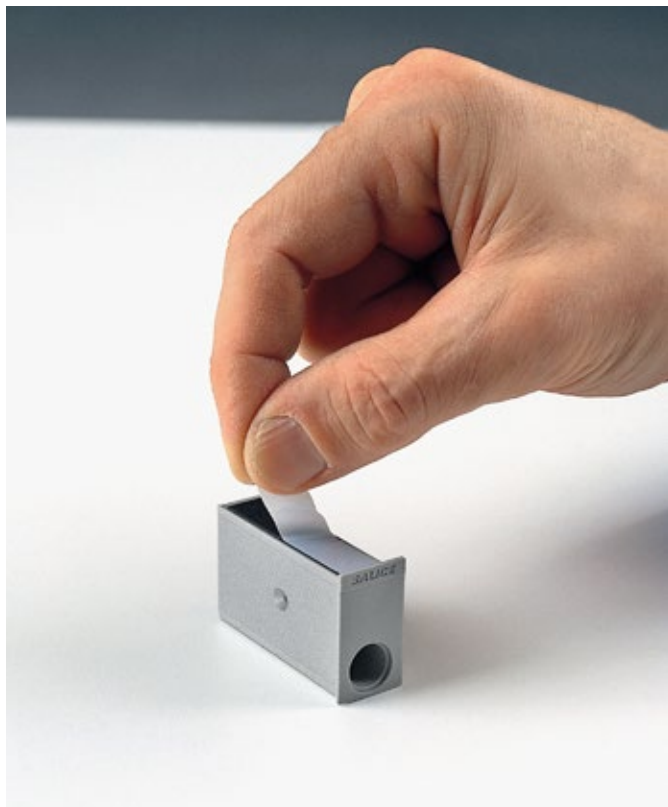



## Smove - Adapter to be screw fixed to the door

### D078XX9

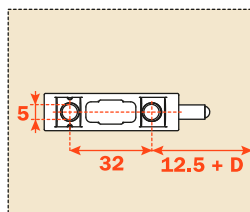

Longitudinal inclined die-cast adapter.  
To be fixed with wood screws or Euroscrews.

Without assembly stop device.  
It is suggested that the adapter is positioned near the centre of the height of the door.

#### Packing

Boxes 500 pcs.  
Pallets 12.000 pcs.

### Installation of Smove with adapter to be screw fixed to the door. Assembly instructions.

Insert Smove frontally into the adapter.

It is suggested that the adapter is positioned near the centre of the height of the door.



## Sliding system for concertina doors

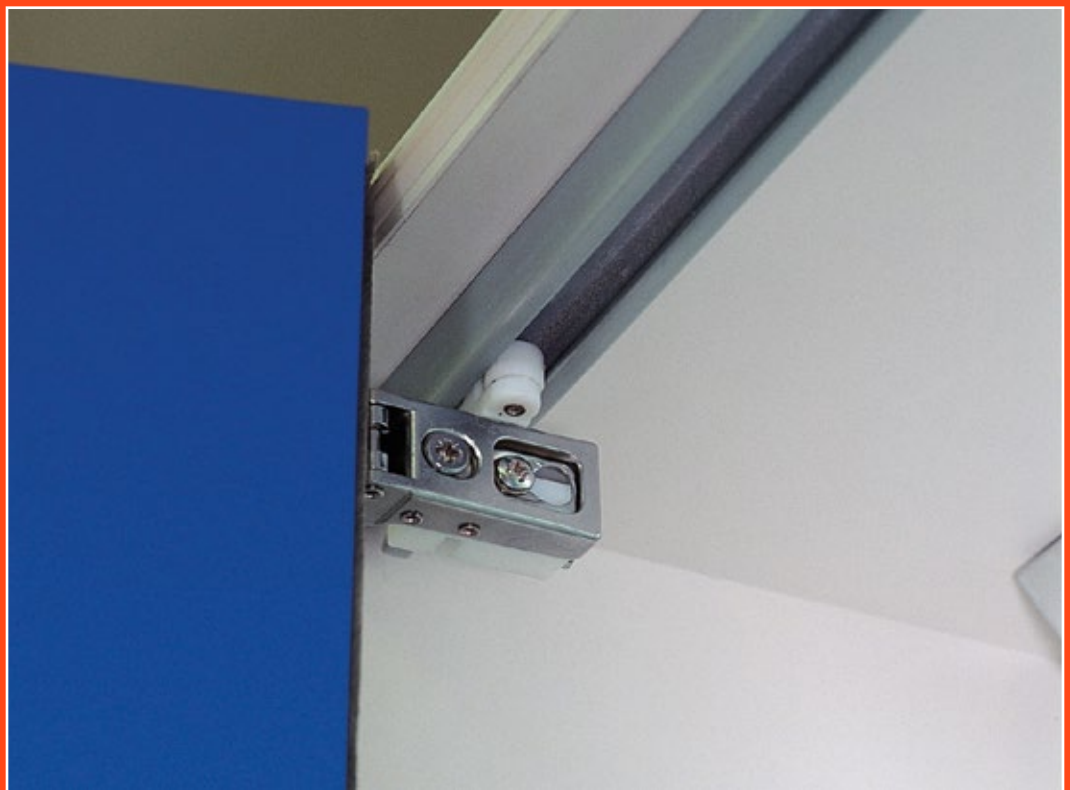



## Sliding system for concertina doors - Technical features

The Salice system for concertina doors has been designed to open both doors on one side only, giving good access to the interior of the cabinet.

Space taken up by the door in the maximum open position is reduced to a minimum (approximately 80 mm).



A nylon strip is available in order to prevent insertion of objects or fingers between doors. This also makes the system dustproof.



To ensure that the door closes fully and securely, particularly when there is some curvature of the door, a locating device is available.



**F1C169**

Hinge for sliding block

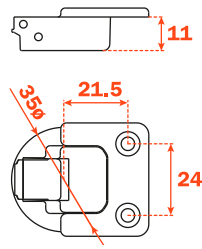

Central hinge



**F1CXE9**  
screw-on

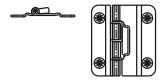

**F1C0E9**

knock-in  
Dowels  $\varnothing$  8x11.5

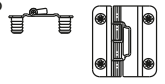

**F1CZ69**

For aluminium-framed doors

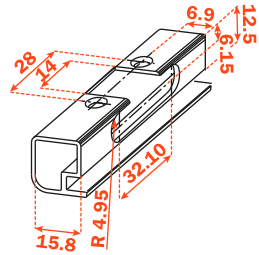

**D206BK5**

Central hinge for the Practical system of aluminium-framed doors.



**F1C069**

Hinge for the Practical system of aluminium-framed doors



Adhesive finger-protection strip

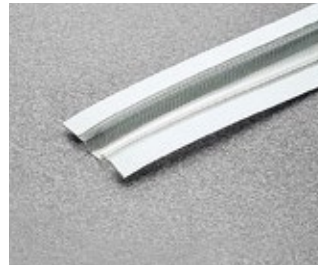

**F1SBA1** white.  
**F1SBA3** black.  
**F1SBAY** neutro.

**F1PVAY**

Long sliding block  
For aluminium-framed doors



**F1RFAY**

Locating device for door

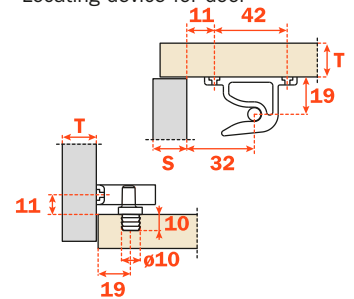

**F1PXAY**

Sliding block



## Calibrated height adjustment

Height adjustment of hinges assembled with the sliding components is achieved through a cam. Through this alignment a parallel movement of the component in the track is achieved. The result is a smooth movement without any binding.

**ATTENTION!** The sliding block does not have a load-bearing function. Therefore it must slide freely inside the track.

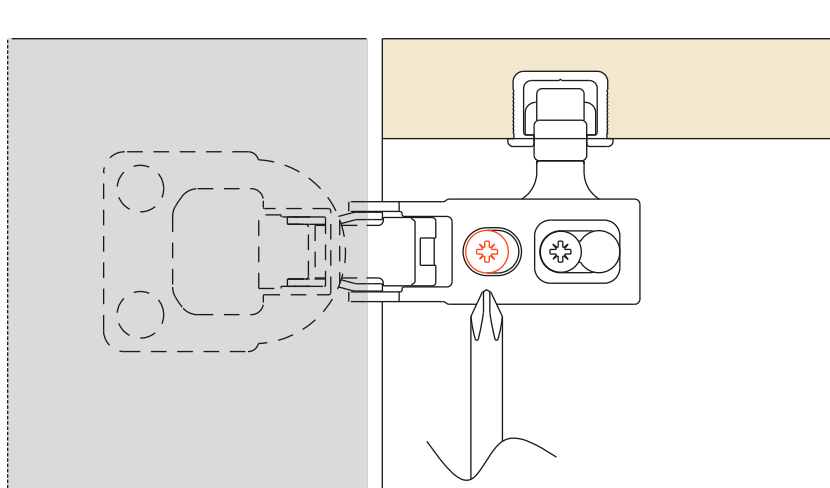
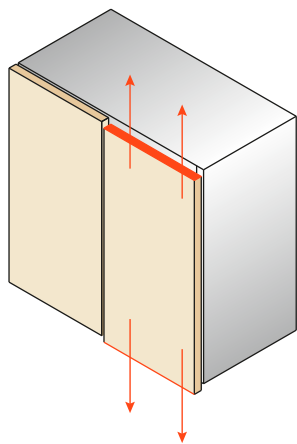

**+2 mm -2 mm**



---

## Depth adjustment

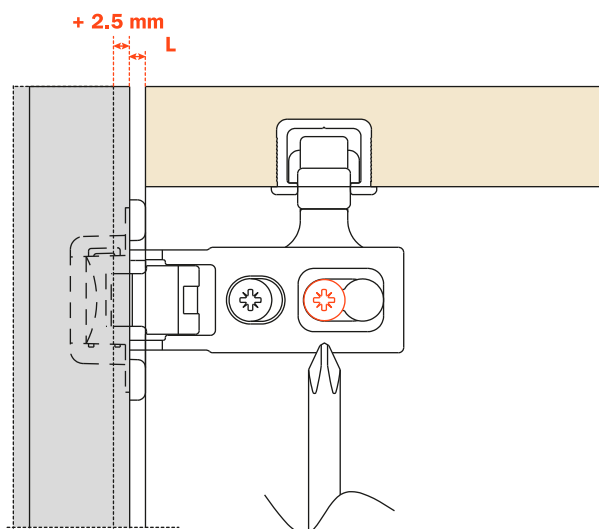
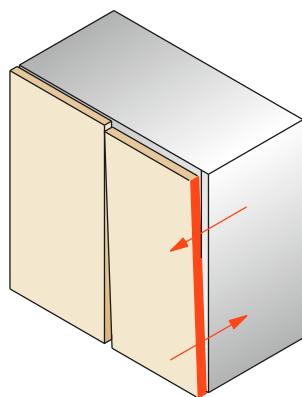
Depth adjustment of the hinges mounted on the sliding component is achieved through the fixing screw of the same hinge. Depth adjustment should be made in conjunction with the hinges mounted on the opposite door. This adjustment is useful to keep the "L" value constant all along front of the furniture.

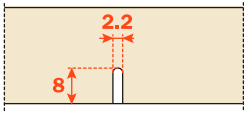
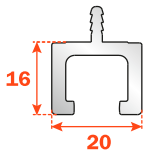

**+2.5 mm**

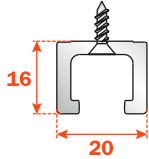
	<b>barb-fixed</b>	<b>screw-on B 3.5 DIN 7982</b>
	 	 
Colours		
white	<b>F1GIA1</b> .....	<b>F1GFA1</b> .....
black	<b>F1GIA3</b> .....	<b>F1GFA3</b> .....
grey	<b>F1GIAG</b> .....	<b>F1GFAG</b> .....
beige	<b>F1GIAP</b> .....	<b>F1GFAP</b> .....

Standard lengths available: 590 mm, 880 mm, 1180 mm. Non-standard lengths can be supplied subject to a minimum order quantity of 900 pieces. The required length should be expressed in millimetres in the last four digits of the product code occupied by the dashes.

Mount the hinges of the fixed door on to the mounting plates on the cabinet side.  
We recommend the use of Salice hinge part number C2A6A99 110° with BAR3R mounting plate or similar.



Position the sliding block inside the track by rotating it 90°.

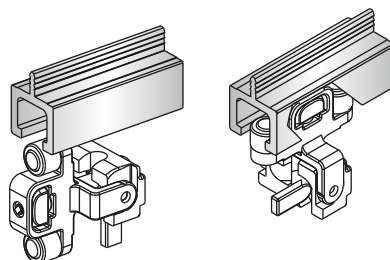

Lock the sliding block into position by turning the marked in orange lever.

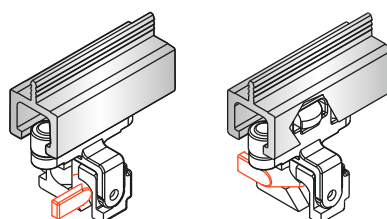

## Application into the top of the cabinet and doors Solution with plastic track barb-fixed or screw-fixed

### Drilling distances without finger-protection strip

To facilitate the assembly of the doors on the cabinet, it is preferable to premount all the hinges.

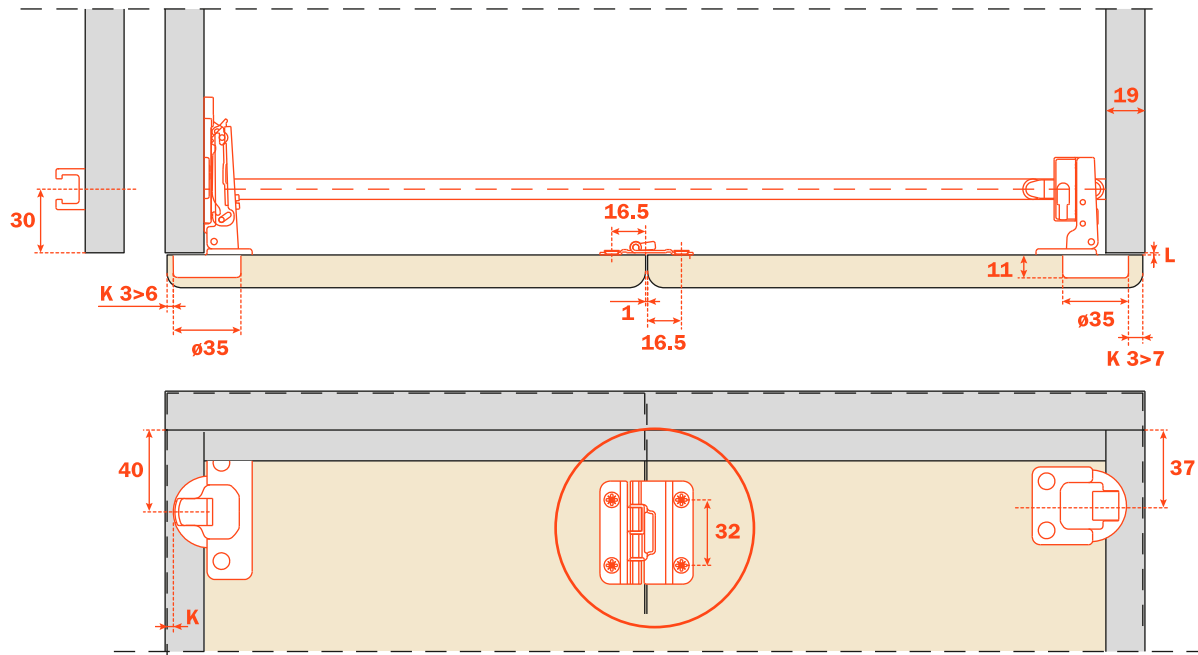

#### Central assembly:

- narrow part to be mounted on the door which is fixed to the cabinet side;
- wider part to be mounted on the moving door.

### Drilling distances with finger-protection strip

To facilitate the assembly of the doors on the cabinet, it is preferable to premount all the hinges.

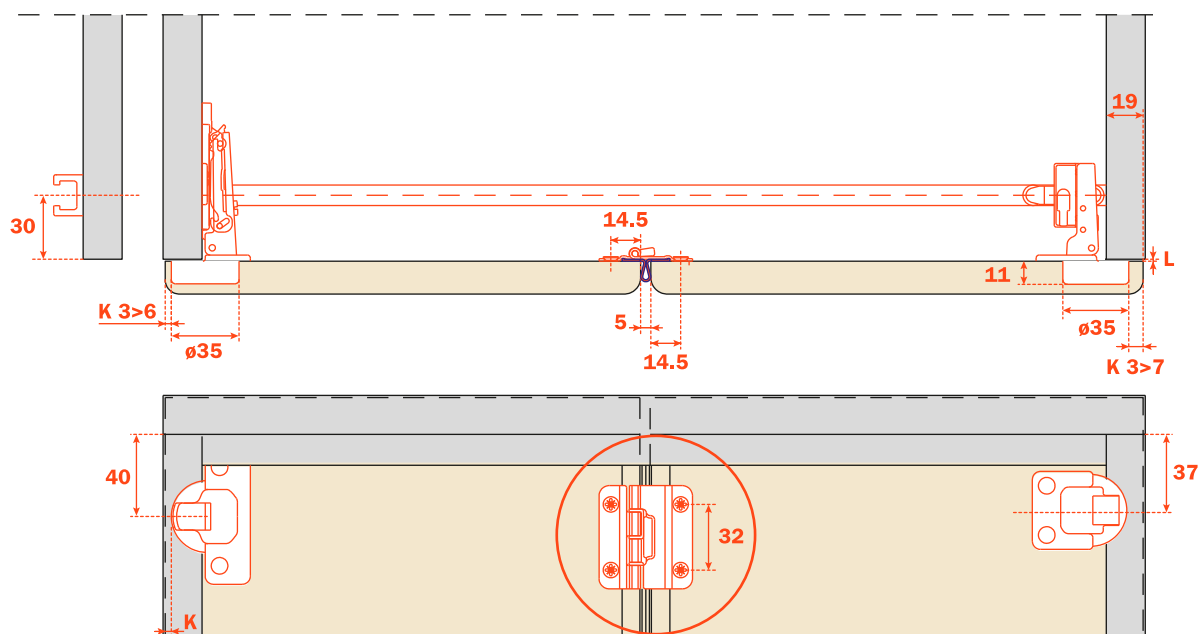

#### Central assembly:

- narrow part to be mounted on the door which is fixed to the cabinet side;
- wider part to be mounted on the moving door.

**Application into the top of the cabinet and doors.**  
**Solution with plastic track barb-fixed or screw-fixed.**

**Glass doors with aluminium-frame**  
**Drilling distances without finger-protection strip and with long sliding block**

To facilitate the assembly of the doors on the cabinet, it is preferable to premount all the hinges.

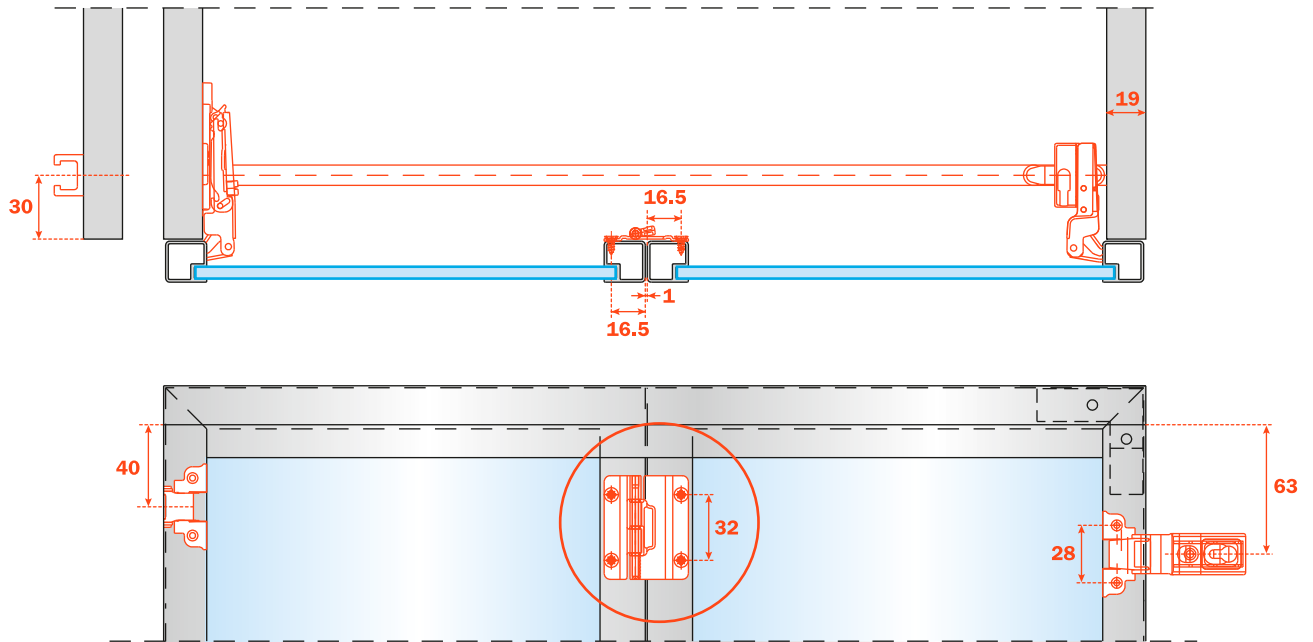

**Central assembly:**  
 - narrow part to be mounted on the door which is fixed to the cabinet side;  
 - wider part to be mounted on the moving door.

**Glass doors with aluminium frame**  
**Drilling distances with finger-protection strip and long sliding block**

To facilitate the assembly of the doors on the cabinet, it is preferable to premount all the hinges.

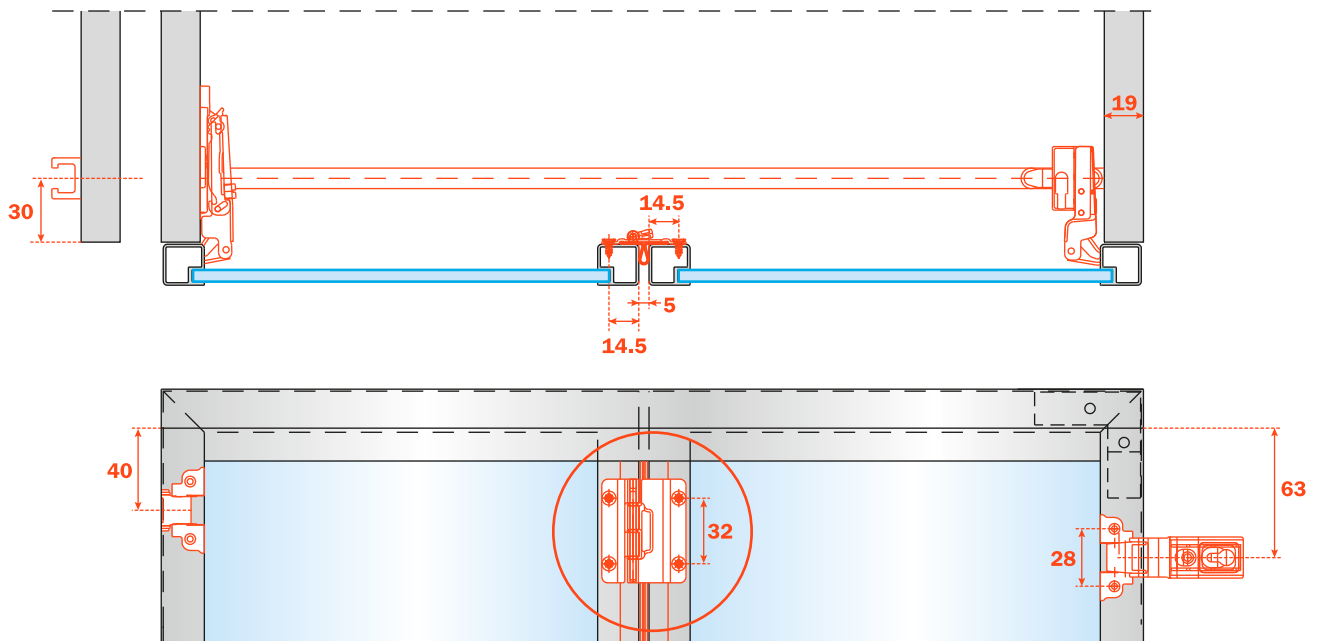

**Central assembly:**  
 - narrow part to be mounted on the door which is fixed to the cabinet side.  
 - wider part to be mounted on the moving door.



**Application into the top of the cabinet and doors**  
**Solution with barb-fix and screw-fix plastic track**

**Glass doors with the Practical system of aluminium-framed doors**

**Distance to be used when finger-protection strip and two-screw (D206BS5) or four-screw (D206BS5L) corner joint are used**

To facilitate the assembly of the doors on the cabinet, it is preferable to premount all the hinges.

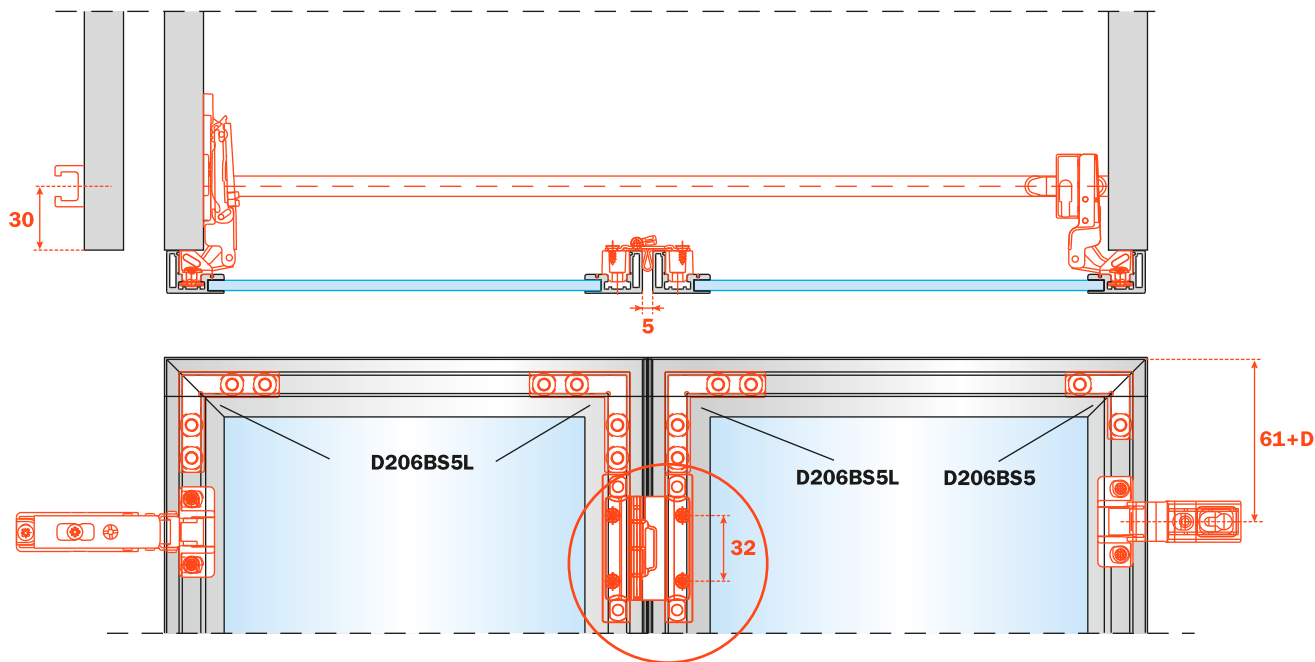

- Central assembly:**
- narrow part to be mounted on the door which is fixed to the cabinet side;
  - wider part to be mounted on the moving door.

**Glass doors with the Practical system of aluminium-framed doors**

**Distance to be used when finger-protection strip and four-screw corner joint (D206BS5L) are used**

To facilitate the assembly of the doors on the cabinet, it is preferable to premount all the hinges.

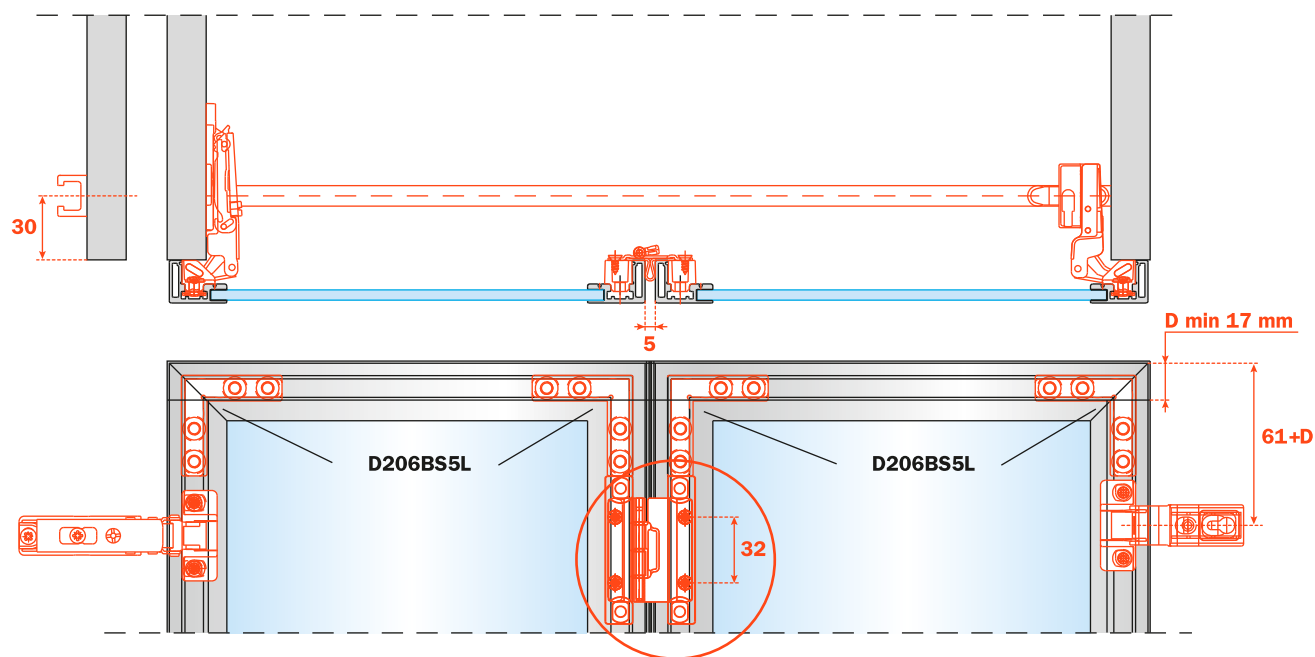

- Central assembly:**
- narrow part to be mounted on the door which is fixed to the cabinet side;
  - wider part to be mounted on the moving door.

**Packaging (standard packaging)**

Elements of the system	Boxes	Pallets
F1C169	300 pcs.	7.200 pcs.
F1PXAY	300 pcs.	7.200 pcs.
F1CXE9	600 pcs.	14.400 pcs.
F1COE9	600 pcs.	14.400 pcs.
F1RFAY	300 pcs.	7.200 pcs.
F1CZ69	300 pcs.	7.200 pcs.
F1CA69	300 pcs.	7.200 pcs.
F1PVAY	300 pcs.	7.200 pcs.
F1CO69	300 pcs.	7.200 pcs.
Adhesive finger-protection strip	200 metres	
Tracks 880 mm - 1180 mm	75 pcs.	
Tracks 590 mm	150 pcs.	

**KIT - Packaging**

F1C169	25 pcs.
F1PXAY	25 pcs.
F1CXE9	75 pcs.
F1GFA.....	25 pcs.
Available in 3 lengths	
and 4 colours	

Code number composition (example)

**F1KFX3X880**

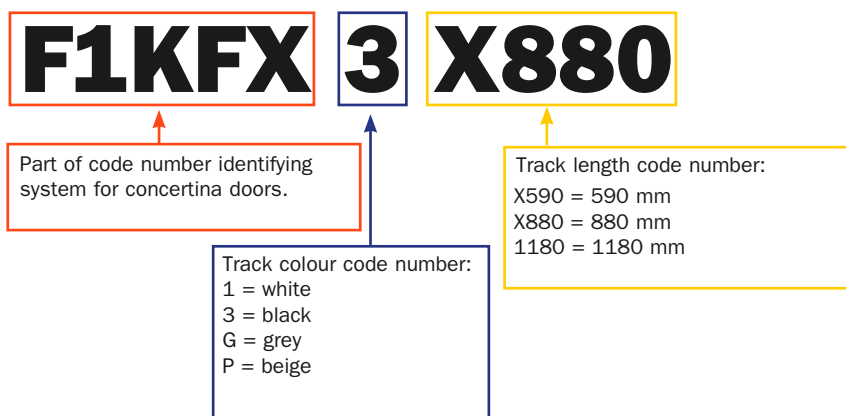



## Lift - Opening systems - Flap door



Lift - Opening systems  
Flap door





## Part number composition

- F** = Lifting system
- R2** = Flap door opening
- D/S** = Right or left versions
- XXXX** = Special options
- SN** = Cover with Salice logo / **99** = Cover with arrangement for screw cover cap
- X** = Colour of the cover
- X1** = Cover with silk-screen printed logo

**FR2XXXXXS**

**D** = right version  
**S** = left version

**G** = grey cover  
**1** = white cover  
**9** = nickel-pl. cover



**FR2XXXX999**  
Part number for Lift system supplied with nickel-plated cover with arrangement for screw cover cap.

Screw cover cap to be ordered separately.



**FR2XXXX\_9X1**  
Part number for Lift system supplied with nickel-plated cover with silk-screen printed logo.



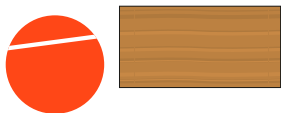

## Components of the system for wooden door



**FR2DXXXXSNX**  
Lifting system - **right** side

Cover

**Colour of the cover:**

G = grey  
1 = white  
9 = nickel-pl.

**Packing**  
Boxes 12 pcs.



**FR2SXXXXSNX**  
Lifting system - **left** side

Cover

**Colour of the cover:**

G = grey  
1 = white  
9 = nickel-pl.

**Packing**  
Boxes 12 pcs.

### To be ordered separately:

**C2\_6A99**



Hinge for door.  
See page 295 to complete the part number with the available fixing systems.

**Packing**  
Boxes 300 pcs.

**BAPGR39**



Mounting plate for the top of the wall cabinet.

Mounting plate for door.

**Packing**  
Boxes 300 pcs.

**FLMGSE XXX** ← Fill with the required piston strength



Gas piston.  
See page 300 and 302 to complete the part number with the appropriate piston strength.

**Packing**  
Boxes 12 pcs.

**D00SSNG**



Smove

For doors of small weight and dimensions.

**Packing**  
Boxes 250 pcs.

**FLMGRE XXX** ← Fill with the required piston strength



Progressive gas piston.  
See page 301 and 303 to complete the part number with the appropriate piston strength.

**Packing**  
Boxes 12 pcs.

**D00FSNG**



Smove

For doors of middle weight and dimensions.

**Packing**  
Boxes 250 pcs.

**D00LSNG**



Smove

For doors of large weight and dimensions.

**Packing**  
Boxes 250 pcs.



## Components of the system for alu-framed door0



**FR2DXXXXSNX**  
Lifting system - **right** side

Cover

**Colour of the cover:**

G = grey  
1 = white  
9 = nickel-pl.

**Packing**  
Boxes 12 pcs.



**FR2SXXXXSNX**  
Lifting system - **left** side

Cover

**Colour of the cover:**

G = grey  
1 = white  
9 = nickel-pl.

**Packing**  
Boxes 12 pcs.

### To be ordered separately:

**C2Z6A99**

Hinge for door



**Packing**  
Boxes 150 pcs.

**BAP\_R39**



**BAPGR39**  
Mounting plate for the top of the wall cabinet.  
**BAP3R39**  
Mounting plate for door.

**Packing**  
Boxes 300 pcs.

**FLMGSE XXX** ← Fill with the required piston strength



Gas piston.  
See page 300 and 302 to complete the part number with the appropriate piston strength.

**Packing**  
Boxes 12 pcs.

**D00SSNG**



Smove  
For doors of small weight and dimensions.

**Packing**  
Boxes 250 pcs.

**FLMGRE XXX** ← Fill with the required piston strength



Progressive gas piston.  
See page 301 and 303 to complete the part number with the appropriate piston strength.

**Packing**  
Boxes 12 pcs.

**D00FSNG**



Smove  
For doors of middle weight and dimensions.

**Packing**  
Boxes 250 pcs.

**DLZXBH9**

Support for plate with fixing screws.



**Packing**  
Boxes 150 pcs.

**D00LSNG**



Smove  
For doors of large weight and dimensions.

**Packing**  
Boxes 250 pcs.



## Components of the system for wooden door with Push opening



**FR2DXXXXSNX**  
Lifting system - **right** side

Cover

**Colour of the cover:**

G = grey  
1 = white  
9 = nickel-pl.

**Packing**  
Boxes 12 pcs.



**FR2SXXXXSNX**  
Lifting system - **left** side

Cover

**Colour of the cover:**

G = grey  
1 = white  
9 = nickel-pl.

**Packing**  
Boxes 12 pcs.

### To be ordered separately:

**C2\_PA99**



Hinge for door.  
See page 295 to complete the part number with the available fixing systems.

**Packing**  
Boxes 300 pcs.

**BAPGR39**



Mounting plate for the top of the wall cabinet.  
Mounting plate for door.

**Packing**  
Boxes 300 pcs.

**FLMGSE XXX** ← Fill with the required piston strength



Gas piston.  
See page 300 and 302 to complete the part number with the appropriate piston strength.

**Packing**  
Boxes 12 pcs.

**D00PSNA**



Smove

**Packing**  
Boxes 250 pcs.

**FLMGRE XXX** ← Fill with the required piston strength



Progressive gas piston.  
See page 301 and 303 to complete the part number with the appropriate piston strength.

**Packing**  
Boxes 12 pcs.



## Components of the system for alu-framed door with Push opening



**FR2DXXXXSNX**  
Lifting system - **right** side

Cover

**Colour of the cover:**

G = grey  
1 = white  
9 = nickel-pl.

**Packing**  
Boxes 12 pcs.



**FR2SXXXXSNX**  
Lifting system - **left** side

Cover

**Colour of the cover:**

G = grey  
1 = white  
9 = nickel-pl.

**Packing**  
Boxes 12 pcs.

### To be ordered separately:

**C2ZPA99**

Hinge for door.



**Packing**  
Boxes 150 pcs.

**BAP\_R39**



**BAPGR39**  
Mounting plate for the top of the wall cabinet.  
**BAP3R29**  
Mounting plate for door.

**Packing**  
Boxes 300 pcs.

**FLMGSE XXX** ← Fill with the required piston strength



Gas piston.  
See page 300 and 302 to complete the part number with the appropriate piston strength.

**Packing**  
Boxes 12 pcs.

**D00PSNA**

Smove



**Packing**  
Boxes 250 pcs.

**FLMGRE XXX** ← Fill with the required piston strength



Progressive gas piston.  
See page 301 and 303 to complete the part number with the appropriate piston strength.

**Packing**  
Boxes 12 pcs.

**DLZXBH9**

Support for plate with fixing screws.



**Packing**  
Boxes 150 pcs.

## Lift - Opening systems - Flap door

The door can be opened with or without a handle. If a handle is used, it can be positioned anywhere on the door. Alternatively, for doors up to 400 mm in height that are not fitted with a handle for aesthetic reasons, the Push self-opening system can be used.





**Push with depth and sideways adjustment**

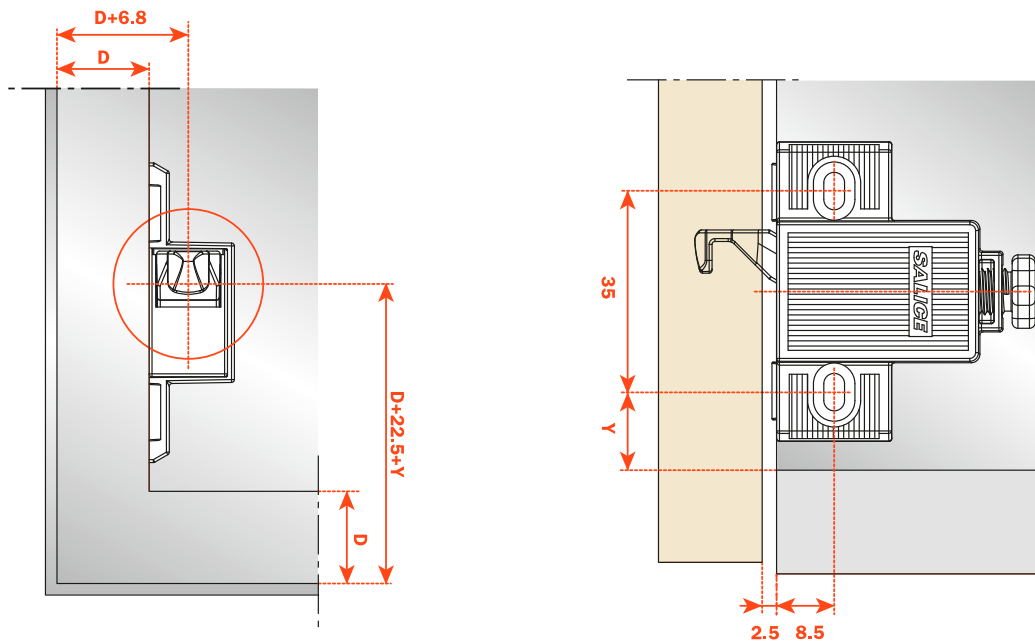

**D = Door overlay on side and base panel of the cabinet**  
**Y = min. 8.5 mm**

**Push without adjustment**

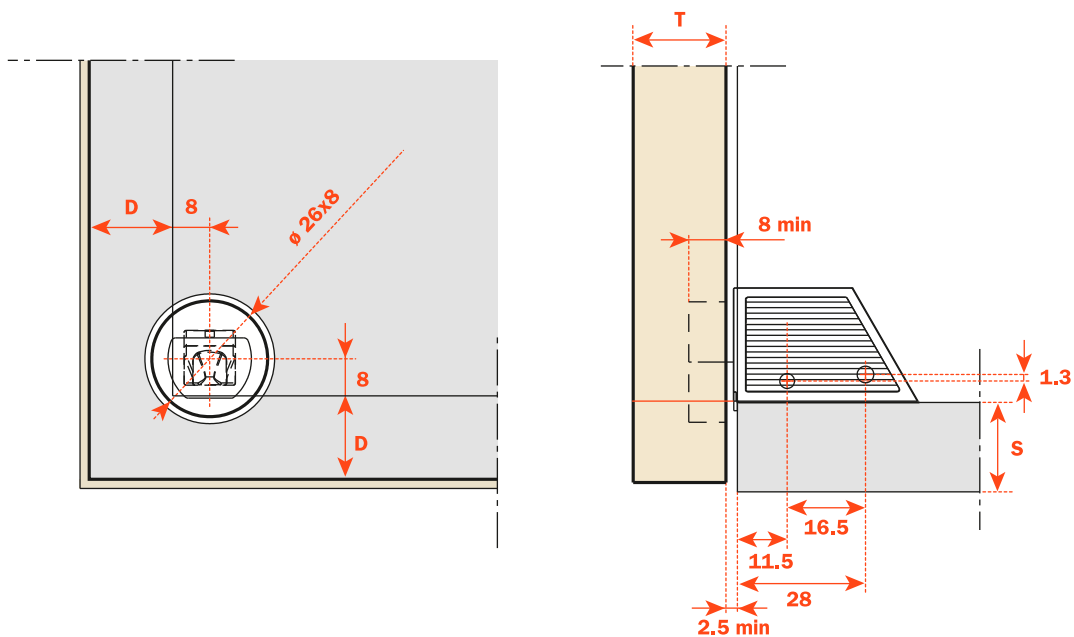

**D = Door overlay on side and base panel of the cabinet**  
**Drilling distance of retaining catch = D + 8**



## Fixing the support to the cabinet side

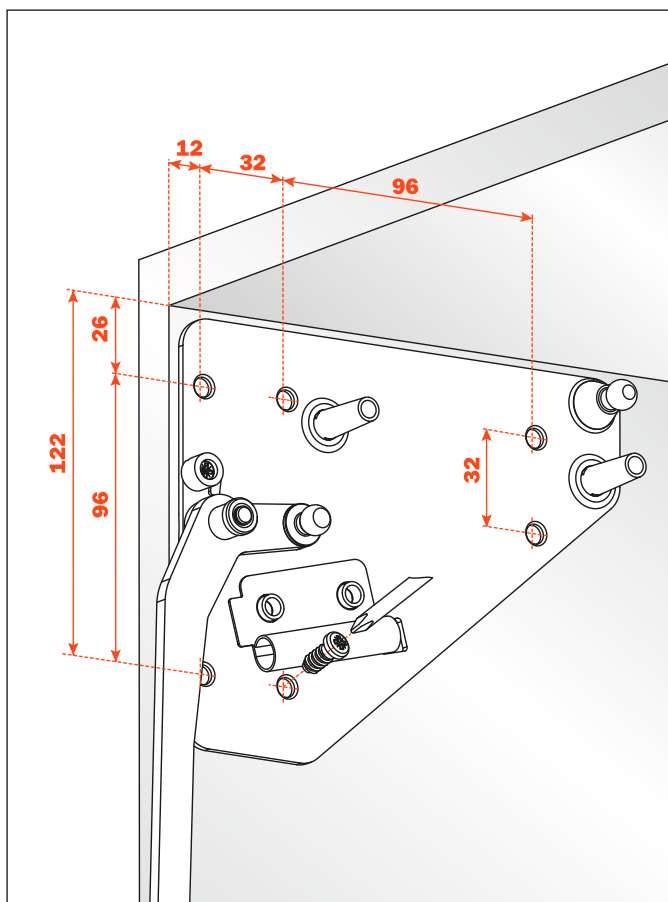

## Deploying the piston

Carefully press each end of the piston securely onto the pins on the bracket and lifting arm, ensuring that the body of the piston is uppermost.

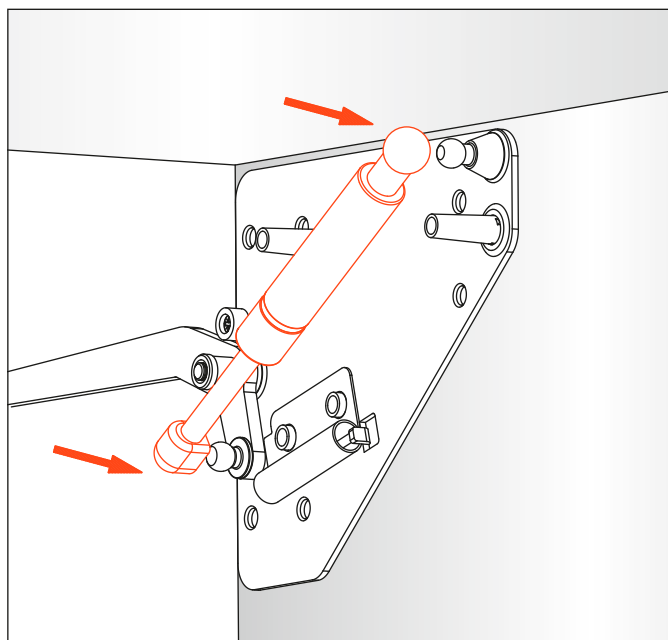

## Drilling pattern for wooden door

### Available fixing systems for the hinge cup:

- A** = wood screw fixing, 48x6 mm drilling
- P** = wood screw fixing, 45x9.5 mm drilling
- U** = wood screw fixing, 52x5.5 mm drilling
- B** = dowel fixing, 48x6 mm drilling
- R** = dowel fixing, 45x9.5 mm drilling
- W** = dowel fixing, 52x5.5 mm drilling
- 6** = Rapido fixing, 48x6 mm drilling
- 7** = Rapido fixing, 45x9.5 mm drilling
- 2** = Rapido fixing, 52x5.5 mm drilling

**D** = sideways and upper overlay

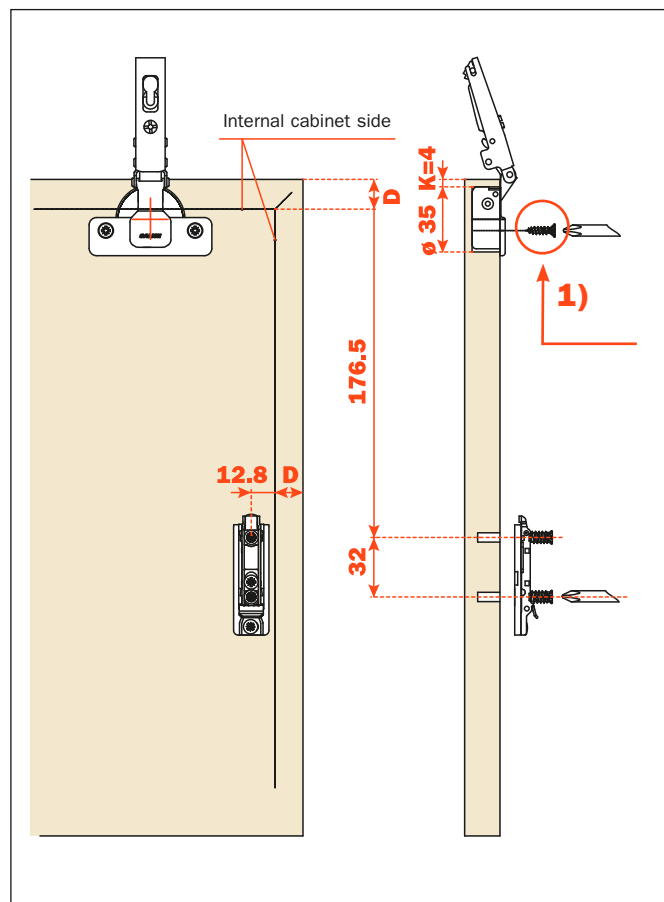

## Drilling pattern for alu-framed door - width min. 17 mm, max. 24 mm

For alu-framed door, fix the mounting plate to the appropriate adapter.

**D** = sideways and upper overlay

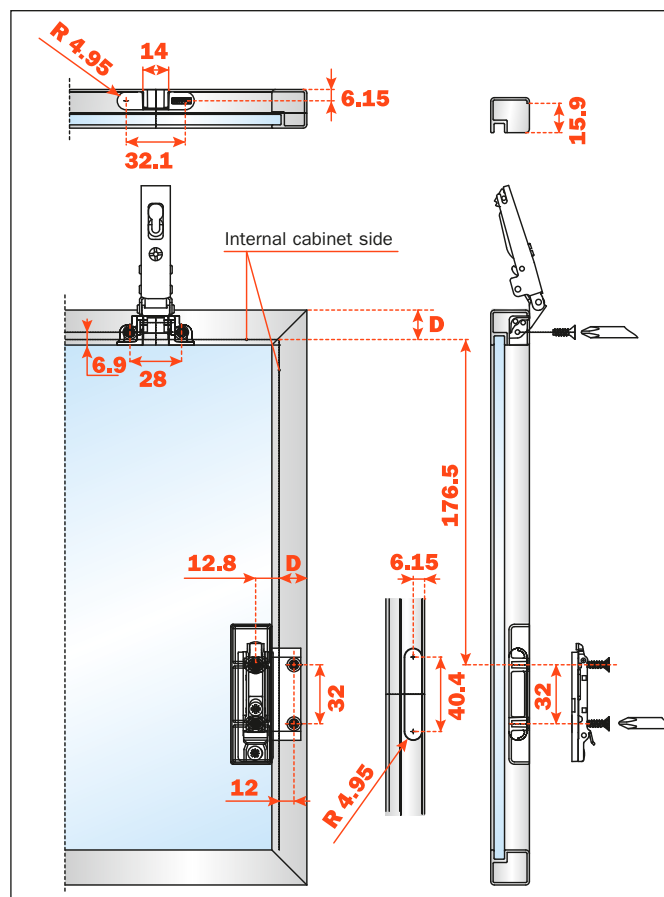

## Drilling pattern for alu-framed door - width min. 45 mm

### Available fixing system for the hinge cup:

- A** = wood screw fixing, 48x6 mm drilling
- P** = wood screw fixing, 45x9.5 mm drilling
- U** = woodscrew fixing, 52x5.5 mm drilling
  
- D** = sideways and upper overlay

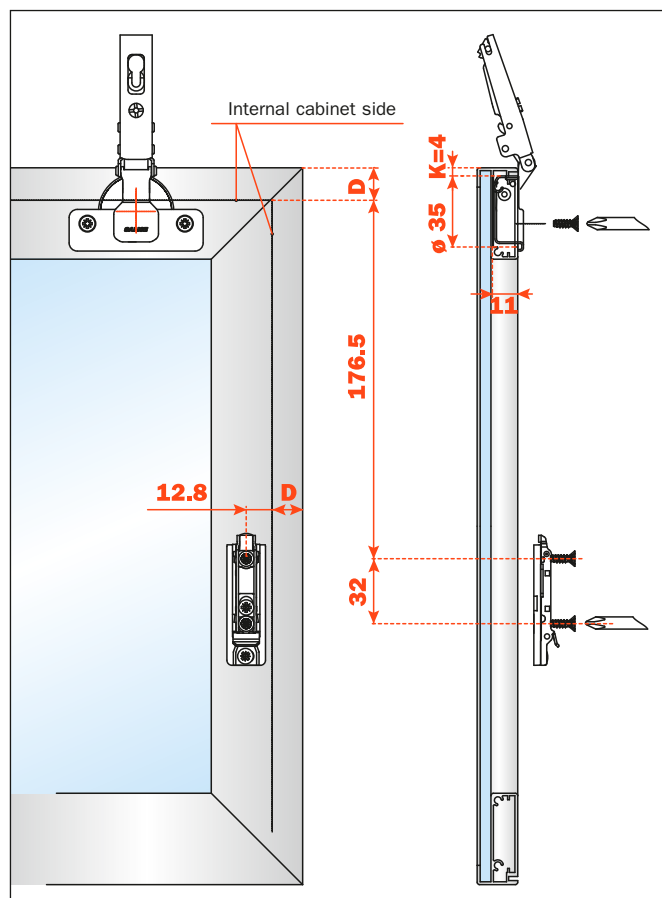

## Fitting the door to the cabinet

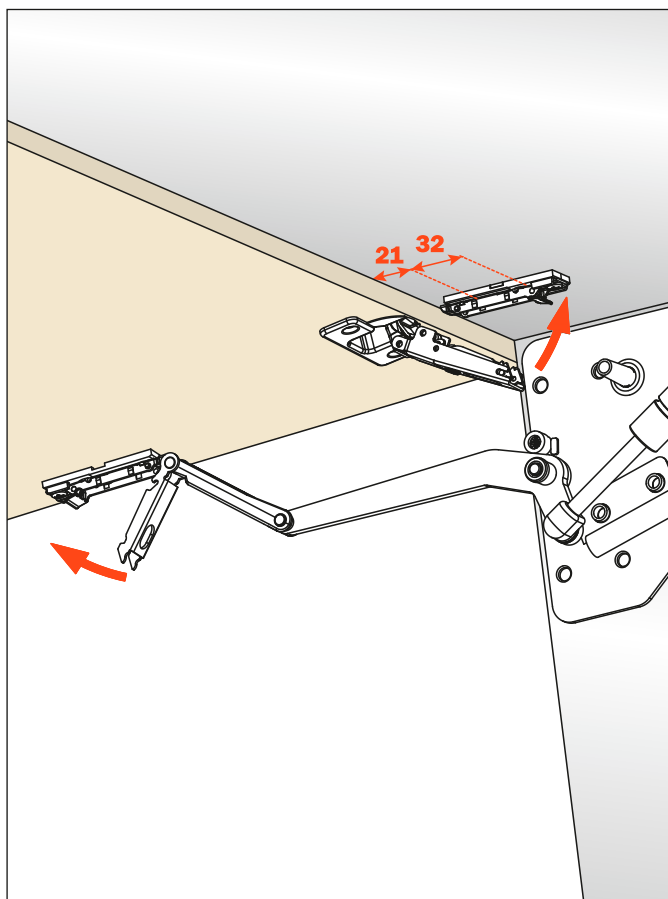

## Installing the Smove

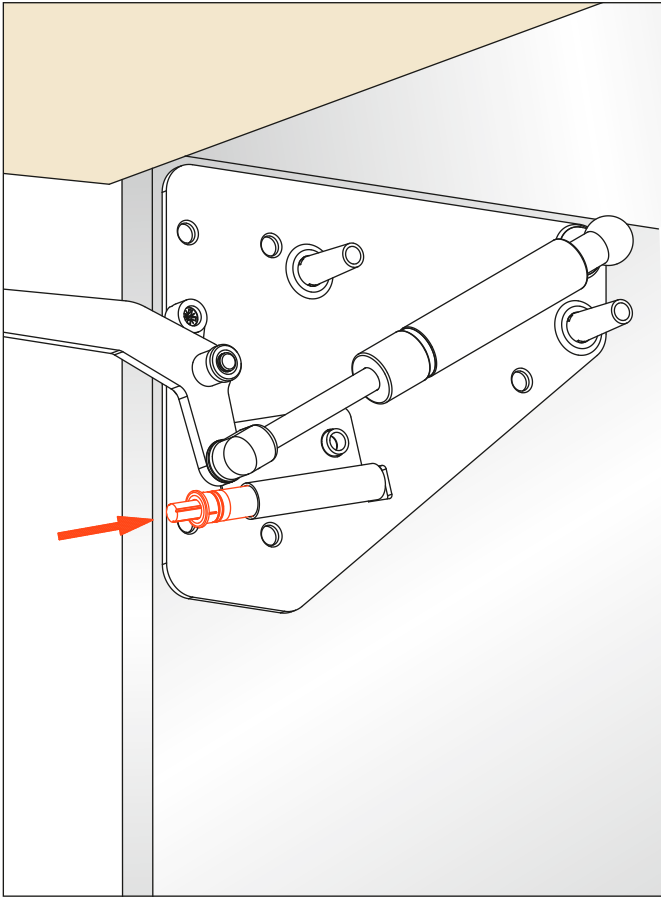

## Adjustment of the opening angle of the door by cam

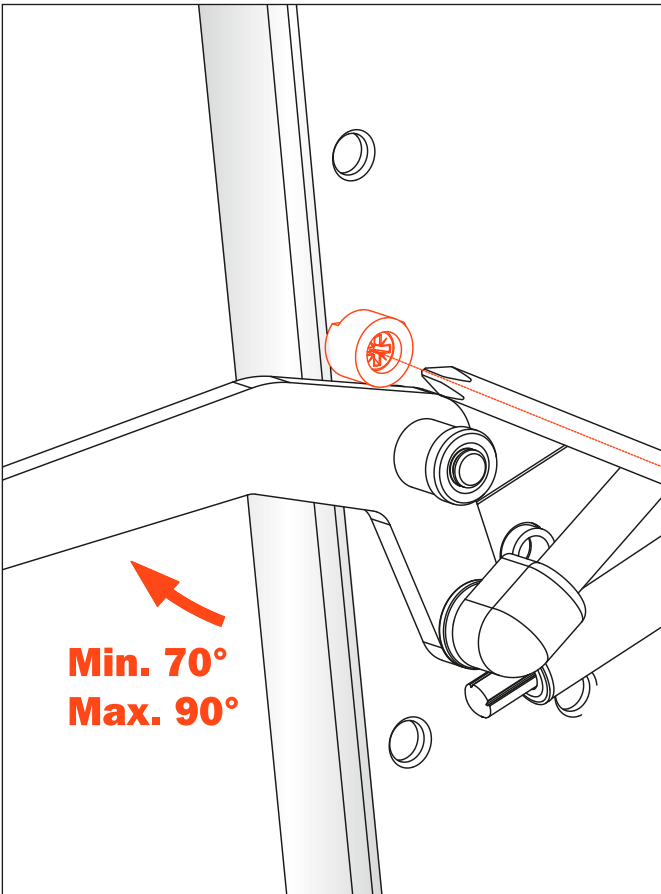

Installing the cover

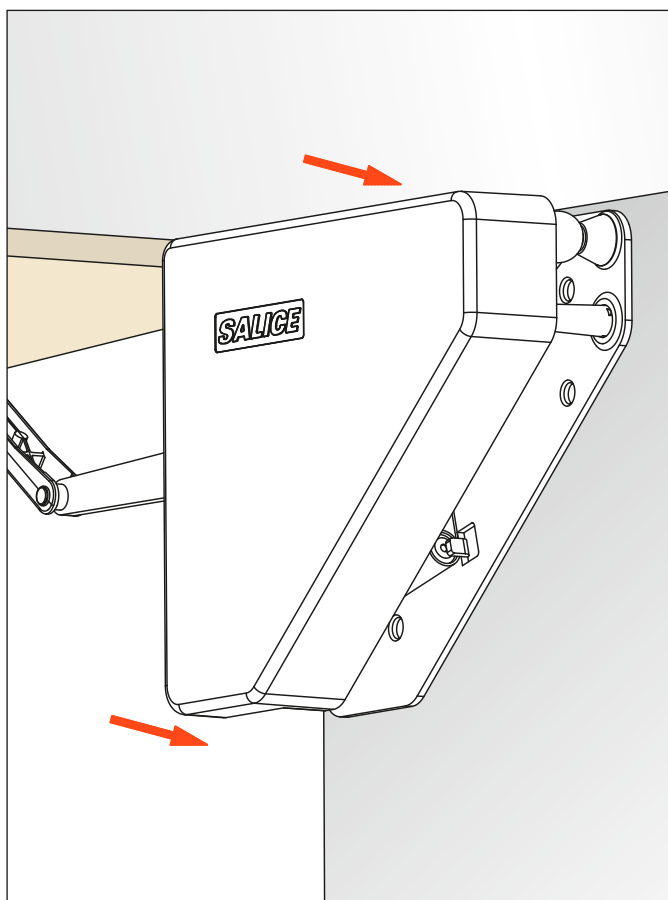

Disassembly

- A) Press the clip of the mounting plate
- B) then press firmly at this point

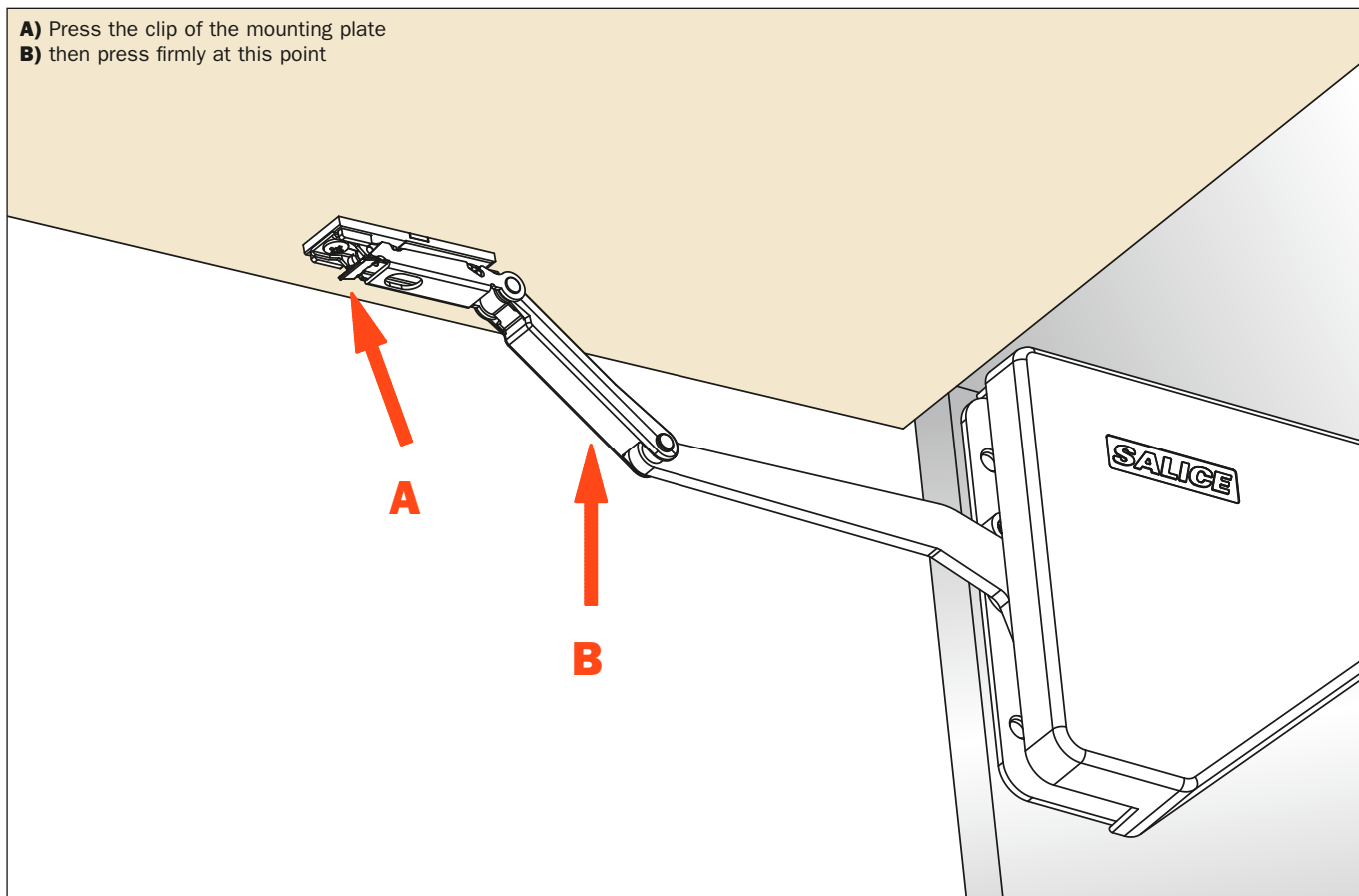

**Dimensions of the system**

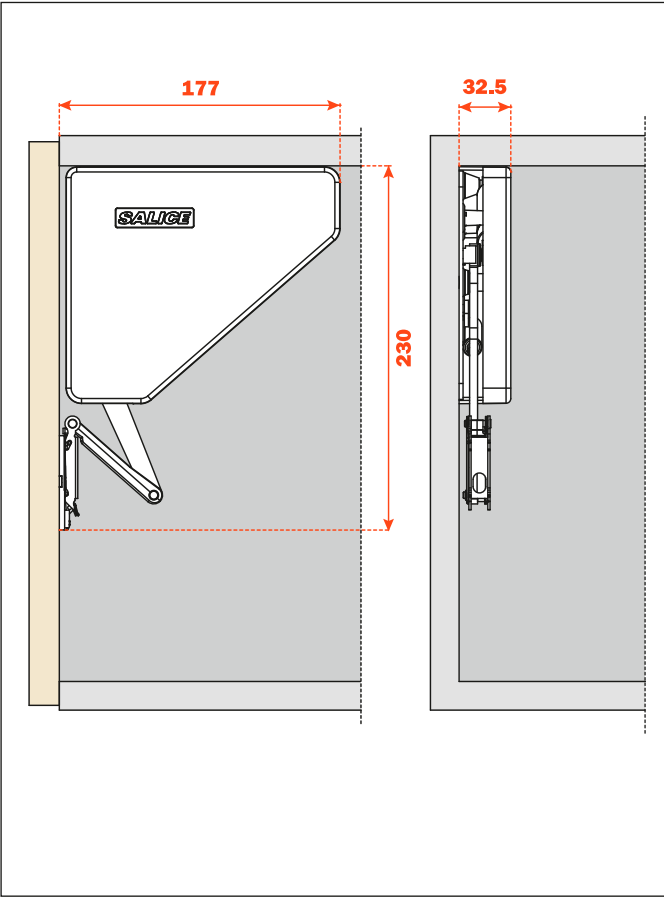



## Chart for FLMGSExxx pistons with single-operation door opening (systems with one piston)

Chart to define the exact strength (N) of the pistons to be used in relationship with the dimensions and weight of the doors.  
It is suggested that some assembly trials are made.  
Our technical Assistance Service is at your disposal for any additional information.

Cabinet width 600, 900 and 1200 mm

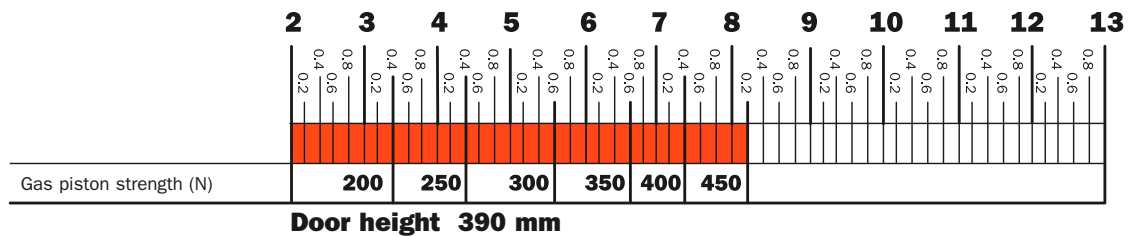
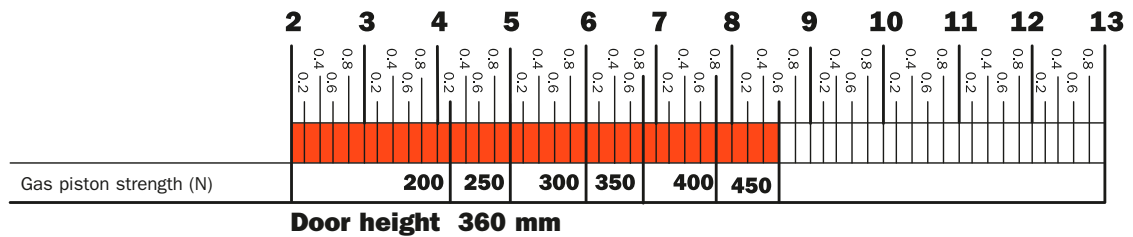
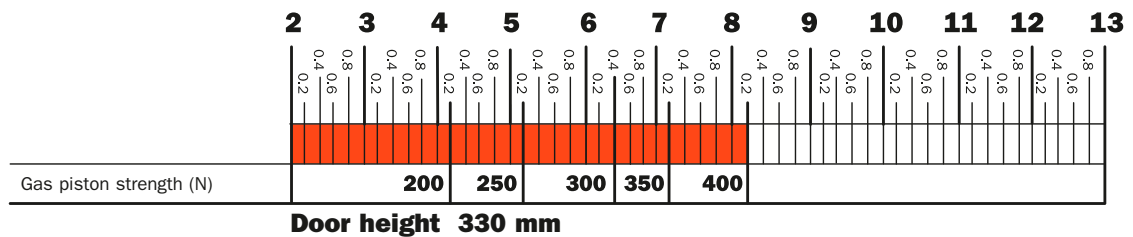
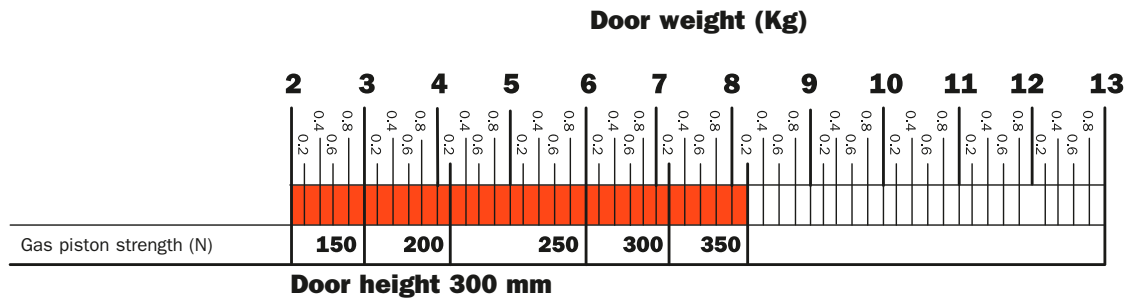

## Chart for FLMGSExxx pistons with single-operation door opening (systems with two pistons)

Chart to define the exact strength (N) of the pistons to be used in relationship with the dimensions and weight of the doors.  
It is suggested that some assembly trials are made.  
Our technical Assistance Service is at your disposal for any additional information.

**Cabinet width 600, 900 and 1200 mm**

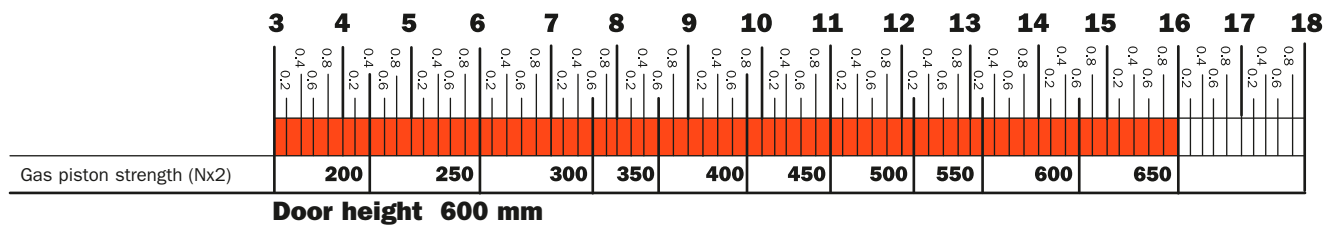
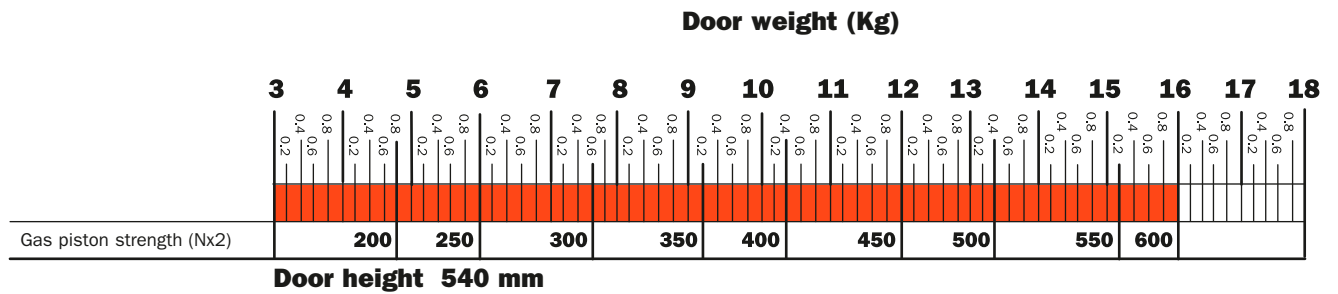

## Chart for FLMGRExxx piston with progressive-operation door opening (systems with one piston)

Chart to define the exact strength (N) of the pistons to be used in relationship with the dimensions and weight of the doors.  
It is suggested that some assembly trials are made. Our technical Assistance Service is at your disposal for any additional information.

Cabinet width (mm)

		Door weight (Kg)											
		2	3	4	5	6	7	8	9	10	11	12	13
600		0.2	0.4	0.6	0.8	0.2	0.4	0.6	0.8	0.2	0.4	0.6	0.8
900		0.2	0.4	0.6	0.8	0.2	0.4	0.6	0.8	0.2	0.4	0.6	0.8
1200		0.2	0.4	0.6	0.8	0.2	0.4	0.6	0.8	0.2	0.4	0.6	0.8
Gas piston strength (N)		150				250				350			

		Door height 300 mm											
		2	3	4	5	6	7	8	9	10	11	12	13
600		0.2	0.4	0.6	0.8	0.2	0.4	0.6	0.8	0.2	0.4	0.6	0.8
900		0.2	0.4	0.6	0.8	0.2	0.4	0.6	0.8	0.2	0.4	0.6	0.8
1200		0.2	0.4	0.6	0.8	0.2	0.4	0.6	0.8	0.2	0.4	0.6	0.8
Gas piston strength (N)		150				250				350			

		Door height 330 mm											
		2	3	4	5	6	7	8	9	10	11	12	13
600		0.2	0.4	0.6	0.8	0.2	0.4	0.6	0.8	0.2	0.4	0.6	0.8
900		0.2	0.4	0.6	0.8	0.2	0.4	0.6	0.8	0.2	0.4	0.6	0.8
1200		0.2	0.4	0.6	0.8	0.2	0.4	0.6	0.8	0.2	0.4	0.6	0.8
Gas piston strength (N)		150				250				350			

		Door height 360 mm											
		2	3	4	5	6	7	8	9	10	11	12	13
600		0.2	0.4	0.6	0.8	0.2	0.4	0.6	0.8	0.2	0.4	0.6	0.8
900		0.2	0.4	0.6	0.8	0.2	0.4	0.6	0.8	0.2	0.4	0.6	0.8
1200		0.2	0.4	0.6	0.8	0.2	0.4	0.6	0.8	0.2	0.4	0.6	0.8
Gas piston strength (N)		150				250				350			

		Door height 390 mm											
		2	3	4	5	6	7	8	9	10	11	12	13
600		0.2	0.4	0.6	0.8	0.2	0.4	0.6	0.8	0.2	0.4	0.6	0.8
900		0.2	0.4	0.6	0.8	0.2	0.4	0.6	0.8	0.2	0.4	0.6	0.8
1200		0.2	0.4	0.6	0.8	0.2	0.4	0.6	0.8	0.2	0.4	0.6	0.8
Gas piston strength (N)		150		250		350		450		550			

		Door height 540 mm											
		2	3	4	5	6	7	8	9	10	11	12	13
600		0.2	0.4	0.6	0.8	0.2	0.4	0.6	0.8	0.2	0.4	0.6	0.8
900		0.2	0.4	0.6	0.8	0.2	0.4	0.6	0.8	0.2	0.4	0.6	0.8
1200		0.2	0.4	0.6	0.8	0.2	0.4	0.6	0.8	0.2	0.4	0.6	0.8
Gas piston strength (N)		150		250		350		450		550		650	

		Door height 600 mm											
		2	3	4	5	6	7	8	9	10	11	12	13
600		0.2	0.4	0.6	0.8	0.2	0.4	0.6	0.8	0.2	0.4	0.6	0.8
900		0.2	0.4	0.6	0.8	0.2	0.4	0.6	0.8	0.2	0.4	0.6	0.8
1200		0.2	0.4	0.6	0.8	0.2	0.4	0.6	0.8	0.2	0.4	0.6	0.8
Gas piston strength (N)		150		250		350		450		550		650	

### Chart for FLMGRExxx piston with progressive-operation door opening (system with two pistons)

Chart to define the exact strength (N) of the pistons to be used in relationship with the dimensions and weight of the doors.  
 It is suggested that some assembly trials are made.  
 Our technical Assistance Service is at your disposal for any additional information.

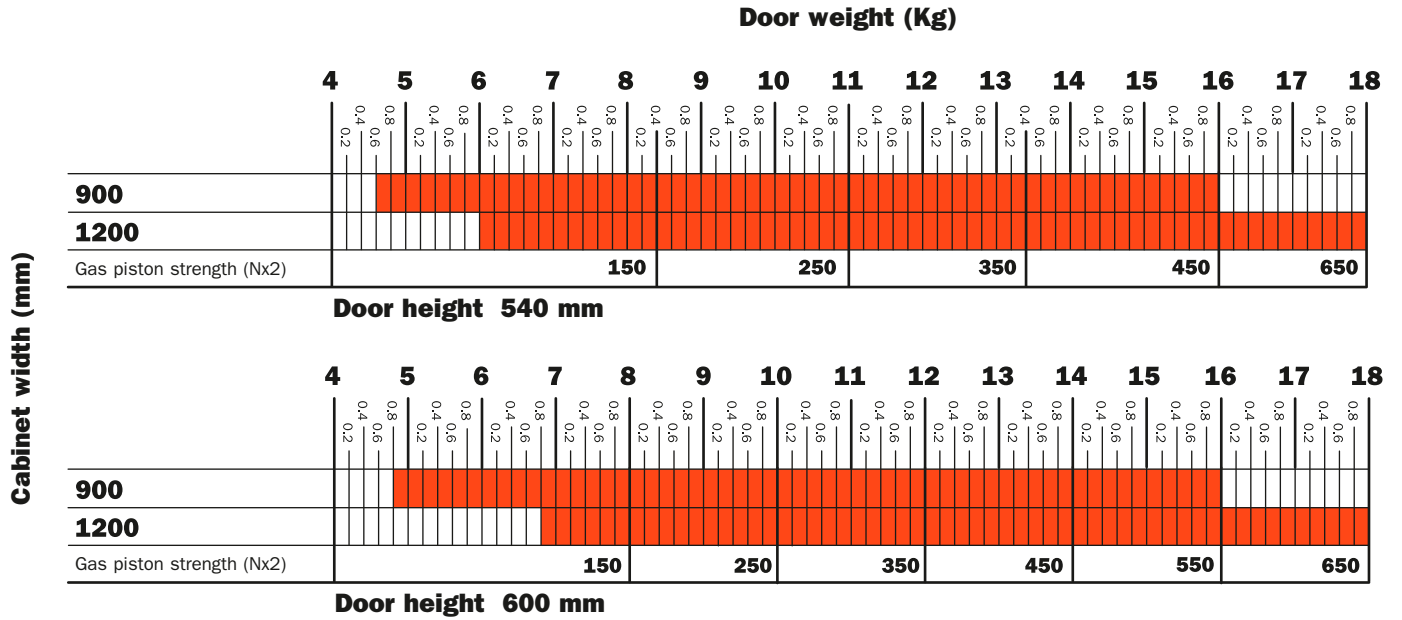



## Lift - Opening systems - Folding door







## Part number composition

- F** = Lifting system
- L1** = Folding door opening
- D/S** = Right or left versions
- LL** = Cabinet height
- XX** = Special options
- SN** = Cover with Salice logo / **99** = Cover with arrangement for screw cover cap
- X** = Colour of the cover
- X1** = Cover with silk-screen printed logo

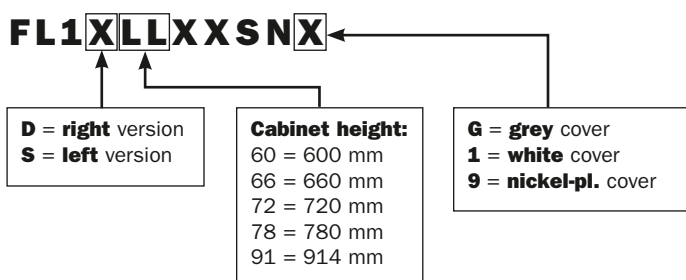

**FL1XLLXX999**

Part number for Lift system supplied with nickel-plated cover with arrangement for screw cover cap.

Screw cover cap to be ordered separately.



**FL1XLLXX\_9X1**

Part number for Lift system supplied with nickel-plated cover with silk-screen printed logo.



## Components of the system for wooden doors



### FL1DLLXSNX

Lifting system - **right** side

Cover

#### Colour of the cover:

G = grey  
1 = white  
9 = nickel-pl.

#### Packing

Boxes 12 pcs.

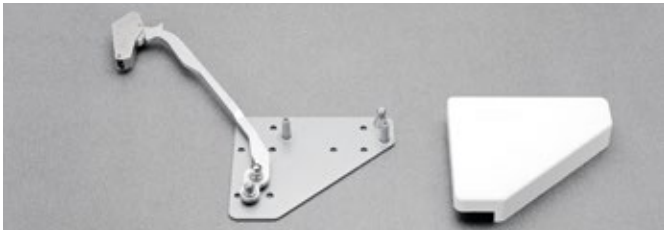

### FL1SLLXSNX

Lifting system - **left** side

Cover

#### Colour of the cover:

G = grey  
1 = white  
9 = nickel-pl.

#### Packing

Boxes 12 pcs.

### To be ordered separately:

#### C2\_6A99



Hinge for door.  
See page 312 to complete the part number with the available fixing systems.

#### Packing

Boxes 300 pcs.

#### BAPGR39



Mounting plate for the top of the wall cabinet.  
Mounting plate for door.

#### Packing

Boxes 300 pcs.

#### FLMGSE **XXX** ← Fill with the required piston strength



Gas piston.  
See page 318 to complete the part number with the appropriate piston strength.

#### Packing

Boxes 12 pcs.

#### D00SSNG



Smove

For doors of small weight and dimensions.

#### Packing

Boxes 250 pcs.

#### FLMGRE **XXX** ← Fill with the required piston strength



Progressive gas piston.  
See page 319 to complete the part number with the appropriate piston strength.

#### Packing

Boxes 12 pcs.

#### D00FSNG



Smove

For doors of middle weight and dimensions.

#### Packing

Boxes 250 pcs.

#### FLC\_E9



Central hinge.  
See page 314 to complete the part number with the available fixing systems.

#### Packing

Boxes 150 pcs.

#### D00LSNG



Smove

For doors of large weight and dimensions.

#### Packing

Boxes 250 pcs.

#### FLC\_E9R



Central hinge with height and sideways adjustment  $\pm 1.5$  mm.  
See page 314 to complete the part number with the available fixing systems.

#### Packing

Boxes 150 pcs.



## Components of the system Upper wooden door - lower alu-framed door



**FL1DLLXXSNX**  
Lifting system - **right** side

Cover

**Colour of the cover:**

G = grey  
1 = white  
9 = nickel-pl.

**Packing**  
Boxes 12 pcs.

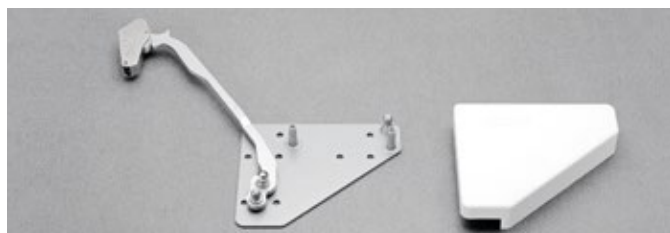

**FL1SLLXXSNX**  
Lifting system - **left** side

Cover

**Colour of the cover:**

G = grey  
1 = white  
9 = nickel-pl.

**Packing**  
Boxes 12 pcs.

### To be ordered separately:

**C2\_6A99**



Hinge for door.  
See page 312 to complete the part number with the available fixing systems.

**Packing**  
Boxes 300 pcs.

**BAP\_R39**



**BAPGR39**  
Mounting plate for the top of the wall cabinet

**BAP3R29**  
Mounting plate for door

**Packing**  
Boxes 300 pcs.

**FLMGSE XXX** ← Fill with the required piston strength



Gas piston.  
See page 318 to complete the part number with the appropriate piston strength.

**Packing**  
Boxes 12 pcs.

**D00SSNG**



Smove  
For doors of small weight and dimensions.

**Packing**  
Boxes 250 pcs.

**FLMGRE XXX** ← Fill with the required piston strength



Progressive gas piston.  
See page 319 to complete the part number with the appropriate piston strength.

**Packing**  
Boxes 12 pcs.

**D00FSNG**



Smove  
For doors of middle weight and dimensions.

**Packing**  
Boxes 250 pcs.

**FLV\_E9R**



Central hinge with height and sideways adjustment  $\pm 1.5$  mm.  
See page 314 and 316 to complete the part number with the available fixing systems.

**Packing**  
Boxes 150 pcs.

**D00LSNG**



Smove  
For doors of large weight and dimensions.

**Packing**  
Boxes 250 pcs.

**FLV\_E9**



Central hinge.  
See page 314 and 316 to complete the part number with the available fixing systems.

**Packing**  
Boxes 150 pcs.

**DLZXBH9**



Support for plate with fixing screws.

**Packing**  
Boxes 150 pcs.



## Components of the system Upper alu-framed door - lower wooden door

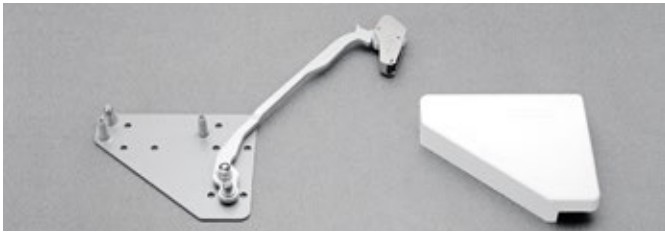

**FL1DLLXSNX**  
Lifting system - **right** side

Cover

**Colour of the cover:**

G = grey  
1 = white  
9 = nickel-pl.

**Packing**  
Boxes 12 pcs.



**FL1SLLXSNX**  
Lifting system - **left** side

Cover

**Colour of the cover:**

G = grey  
1 = white  
9 = nickel-pl.

**Packing**  
Boxes 12 pcs.

### To be ordered separately:

**C2Z6A99**

Hinge for door



**Packing**  
Boxes 150 pcs.

**BAPGR39**

Mounting plate for the top of  
the wall cabinet.  
Mounting plate for door.



**Packing**  
Boxes 300 pcs.

**FLMGSE [XXX]** ← Fill with the required piston strength



Gas piston.  
See page 318 to complete  
the part number with the  
appropriate piston strength.

**Packing**  
Boxes 12 pcs.

**D00SSNG**

Smove

For doors of small weight and  
dimensions.



**Packing**  
Boxes 250 pcs.

**FLMGRE [XXX]** ← Fill with the required piston strength



Progressive gas piston.  
See page 319 to complete  
the part number with the  
appropriate piston strength.

**Packing**  
Boxes 12 pcs.

**D00FSNG**

Smove

For doors of middle weight and  
dimensions.



**Packing**  
Boxes 250 pcs.

**FLW\_E9**

Central hinge.  
See page 314 and 316 to  
complete the part number with  
the available fixing systems.



**Packing**  
Boxes 150 pcs.

**D00LSNG**

Smove

For doors of large weight and  
dimensions.



**Packing**  
Boxes 250 pcs.



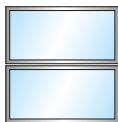

## Components of the system for alu-framed doors



**FL1DLLXSNX**  
Lifting system - **right** side

Cover

**Colour of the cover:**

G = grey  
1 = white  
9 = nickel-pl.

**Packing**  
Boxes 12 pcs.

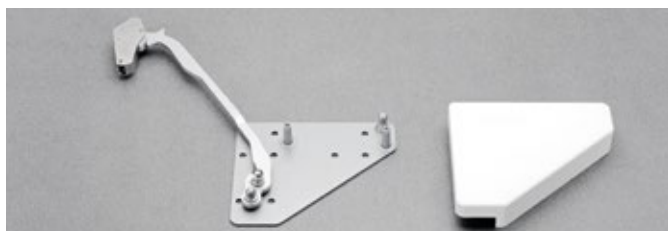

**FL1SLLXSNX**  
Lifting system - **left** side

Cover

**Colour of the cover:**

G = grey  
1 = white  
9 = nickel-pl.

**Packing**  
Boxes 12 pcs.

### To be ordered separately:

**C2Z6A99**

Hinge for door



**Packing**  
Boxes 150 pcs.

**BAP\_R39**



**BAPGR39**  
Mounting plate for the top of the wall cabinet.

**BAP3R29**  
Mounting plate for door

**Packing**  
Boxes 300 pcs.

**FLMGSE XXX** ← Fill with the required piston strength



Gas piston.  
See page 318 to complete the part number with the appropriate piston strength.

**Packing**  
Boxes 12 pcs.

**D00SSNG**



Smove

For doors of small weight and dimensions.

**Packing**  
Boxes 250 pcs.

**FLMGRE XXX** ← Fill with the required piston strength



Progressive gas piston.  
See page 319 to complete the part number with the appropriate piston strength.

**Packing**  
Boxes 12 pcs.

**D00FSNG**



Smove

For doors of middle weight and dimensions.

**Packing**  
Boxes 250 pcs.

**DLZXBH9**

Support for plate with fixing screws.



**Packing**  
Boxes 150 pcs.

**D00LSNG**



Smove

For doors of large weight and dimensions.

**Packing**  
Boxes 250 pcs.

**FLZXE9**

Central hinge.



**Packing**  
Boxes 150 pcs.

### Fixing the support to the cabinet side

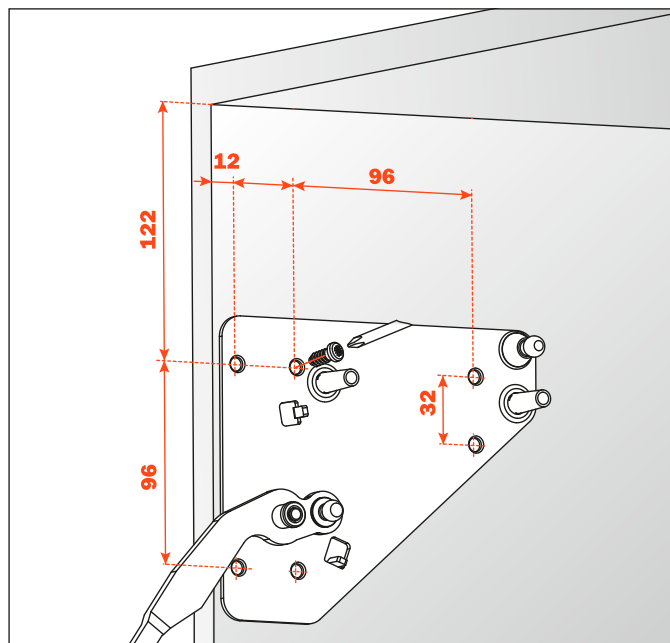

### Deploying the piston

Carefully press each end of the piston securely onto the pins on the bracket and lifting arm, ensuring that the body of the piston is uppermost.

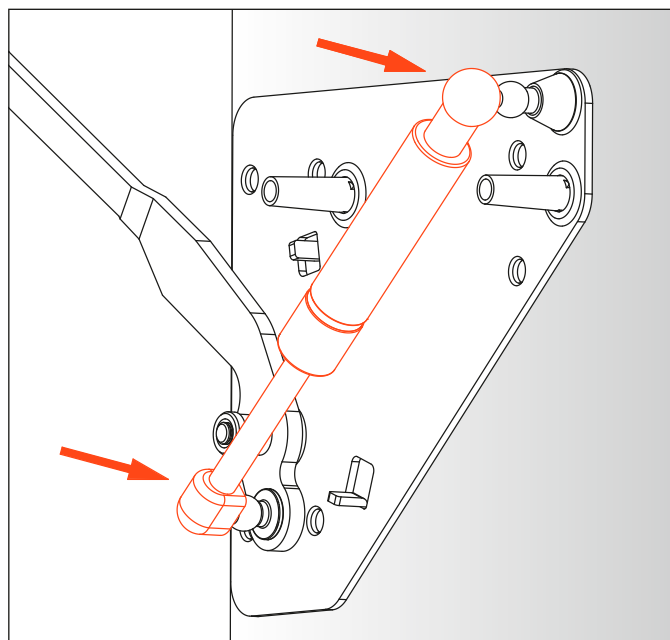



## Installing the Smove

We suggest:

**DOOFSNG** for doors up to 6 kg

**DOOLNSG** for doors over 6 kg

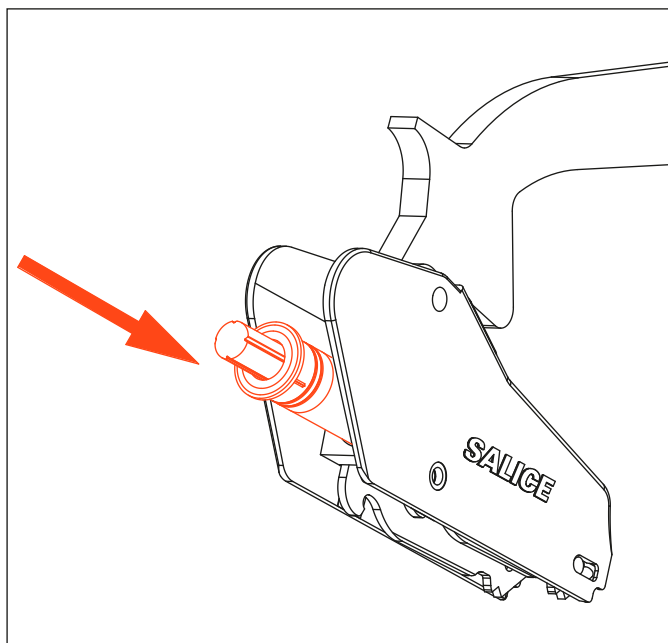

## Drilling pattern for the upper wooden door

Available fixing systems for the hinge cup:

- A** = wood screw fixing, 48x6 mm drilling
- P** = wood screw fixing, 45x9.5 mm drilling
- U** = wood screw fixing, 52x5.5 mm drilling
- B** = dowel fixing, 48x6 mm drilling
- R** = dowel fixing, 45x9.5 mm drilling
- W** = dowel fixing, 52x5.5 mm drilling
- 6** = Rapido fixing, 48x6 mm drilling
- 7** = Rapido fixing, 45x9.5 mm drilling
- 2** = Rapido fixing, 52x5.5 mm drilling

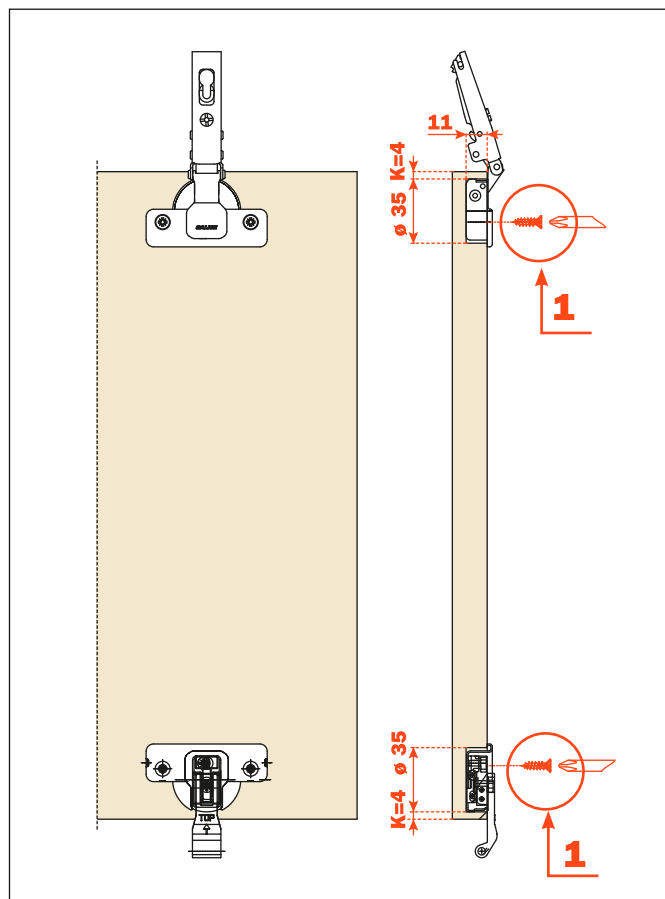
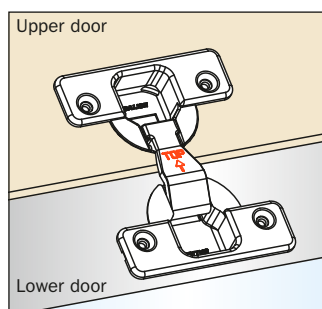
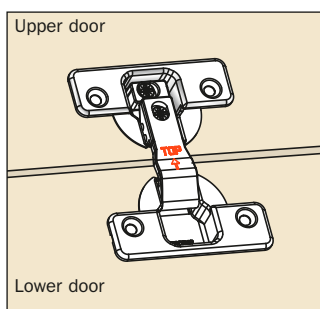

**Drilling pattern for the upper alu-framed door - width min. 17 mm, max. 24 mm**

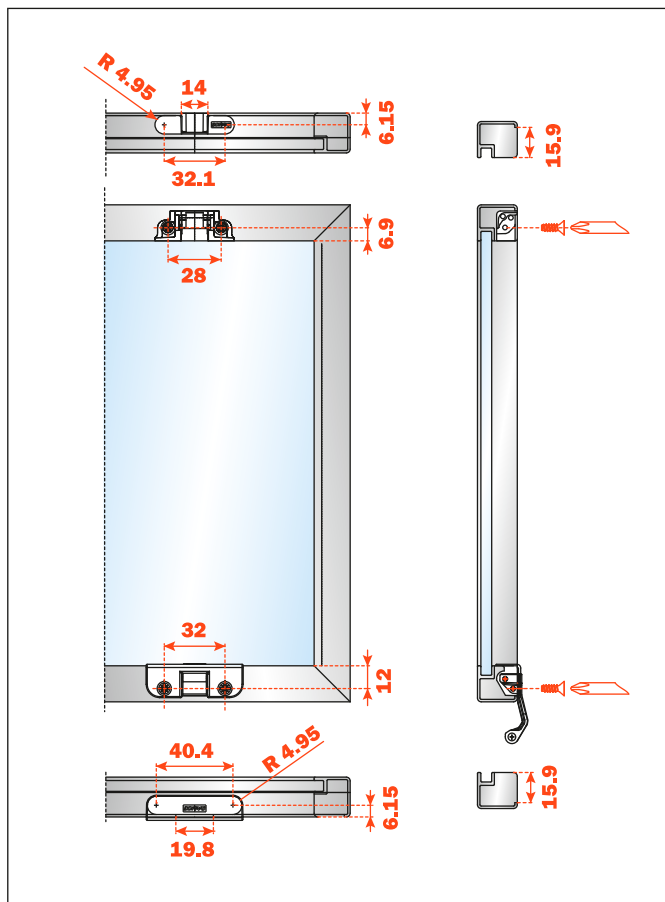
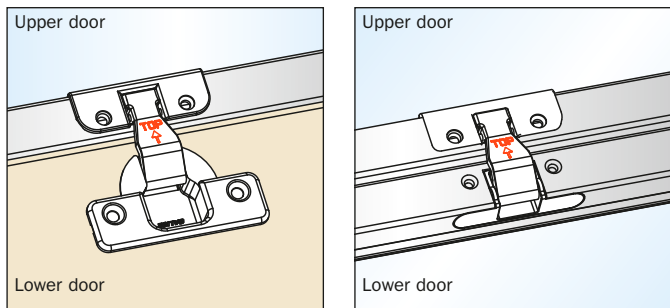

**Drilling pattern for the upper alu-framed door - width min. 45 mm**

**Available fixing systems for the hinge cup:**

- A** = woodscrew fixing, 48x6 mm drilling
- P** = woodscrew fixing, 45x9.5 mm drilling
- U** = woodscrew fixing, 52x5.5 mm drilling

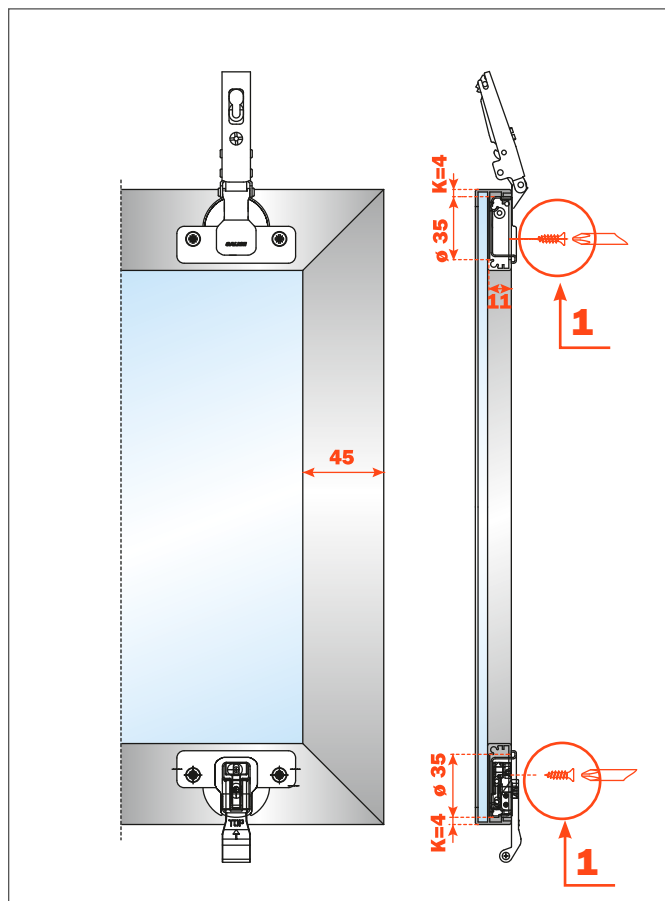
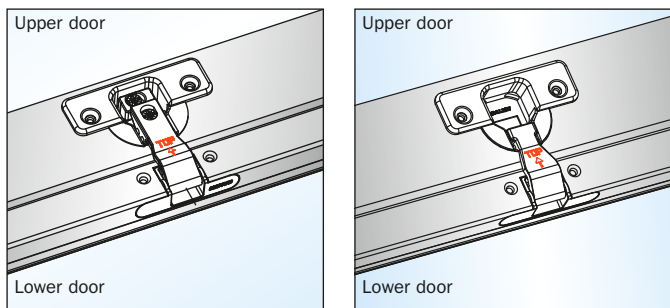

## Drilling pattern for the lower wooden door

### Available fixing systems for the hinge cup:

- A** = wood screw fixing, 48x6 mm drilling
- P** = wood screw fixing, 45x9.5 mm drilling
- U** = wood screw fixing, 52x5.5 mm drilling
- B** = dowel fixing, 48x6 mm drilling
- R** = dowel fixing, 45x9.5 mm drilling
- W** = dowel fixing, 52x5.5 mm drilling
- 6** = Rapido fixing, 48x6 mm drilling
- 7** = Rapido fixing, 45x9.5 mm drilling
- 2** = Rapido fixing, 52x5.5 mm drilling

**D** = sideways overlay

\* Dimension is valid for cabinet heights 600, 660, 720 and 780 mm. For cabinets of different heights, please consult Salice customer service for the correct value.

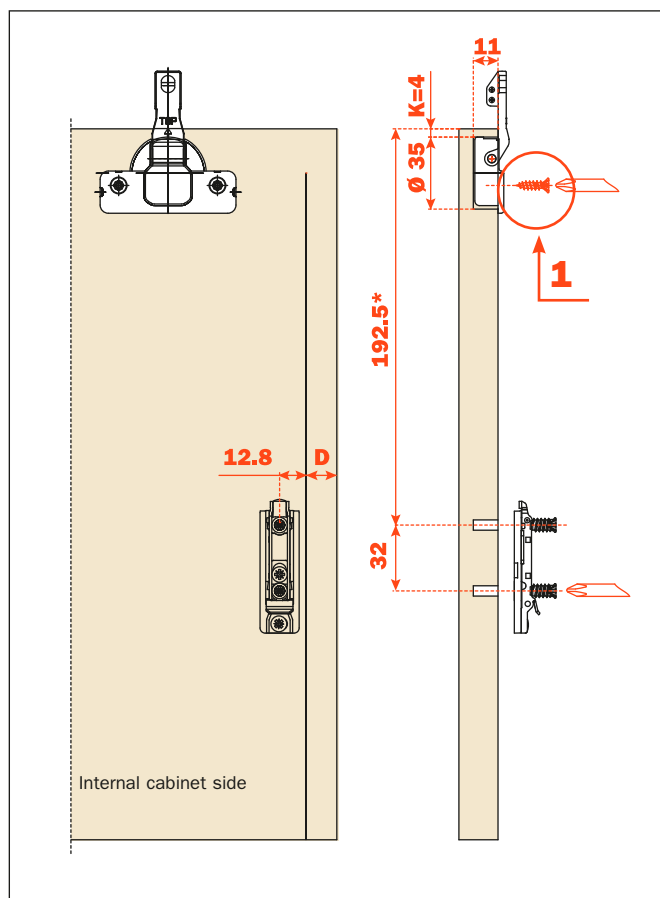
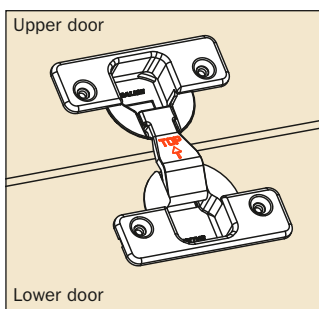
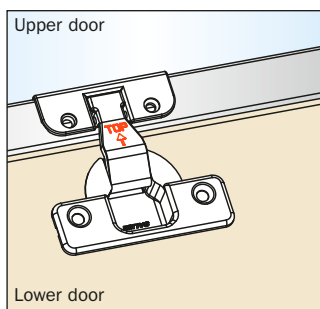

## Drilling pattern for the lower alu-framed door width min. 17 mm, max. 24 mm

For alu-framed door, fix the mounting plate to the appropriate adapter.

**D** = sideways overlay

\* Dimension is valid for cabinet heights 600, 660, 720 and 780 mm. For cabinets of different heights, please consult Salice customer service for the correct value.

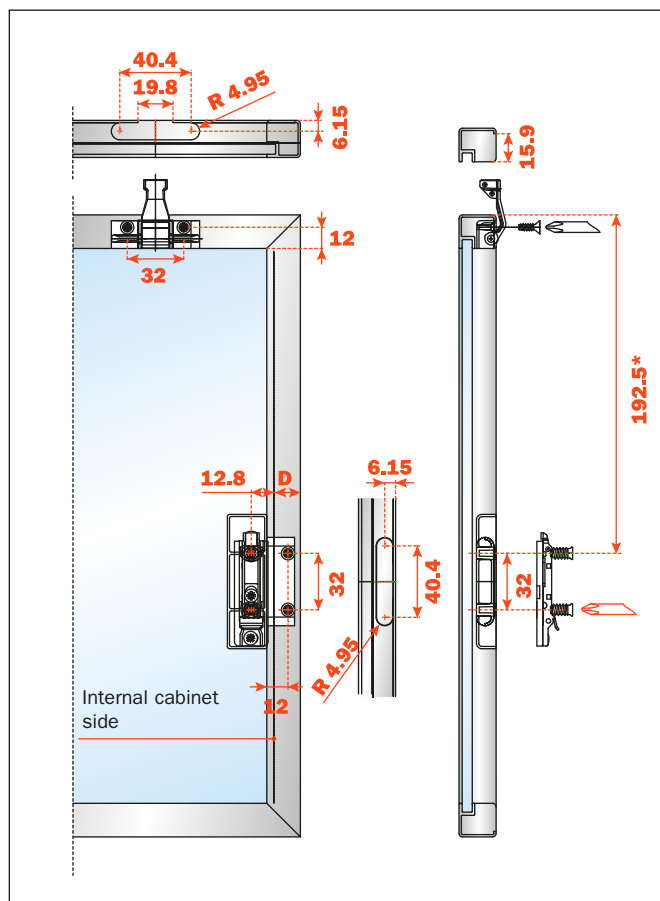
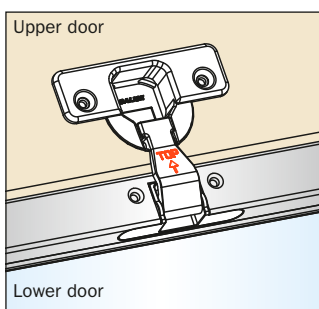
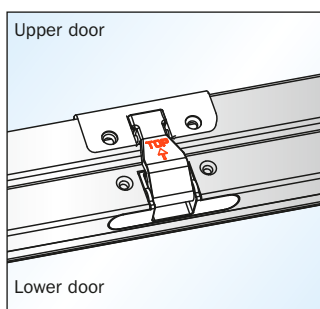
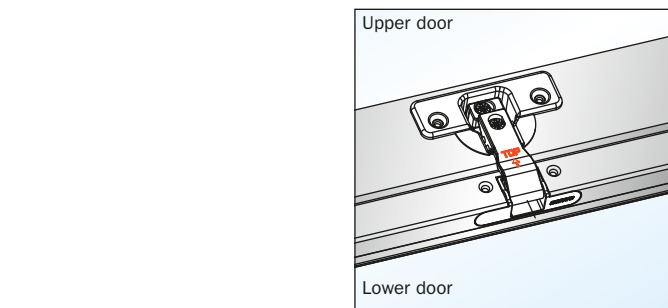

## Drilling pattern for the lower alu-framed door - width min. 45 mm

### Available fixing systems for the hinge cup:

**A** = wood screw fixing, 48x6 mm drilling

**P** = wood screw fixing, 45x9.5 mm drilling

**U** = wood screw fixing, 52x5.5 mm drilling

**D** = sideways overlay

\* Dimension is valid for cabinet heights 600, 660, 720 and 780 mm.

For cabinets of different heights, please consult Salice customer service for the correct value.

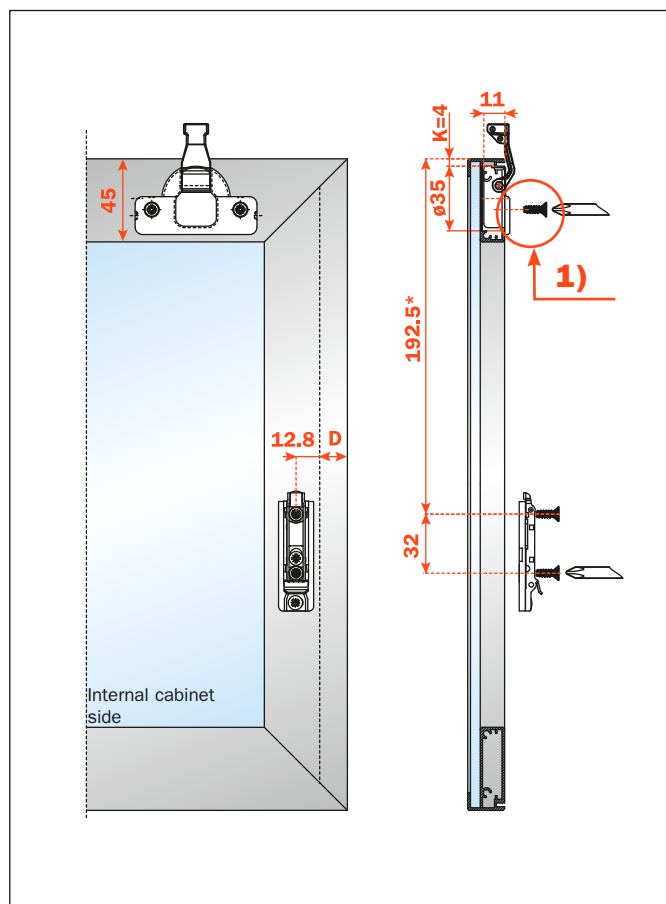
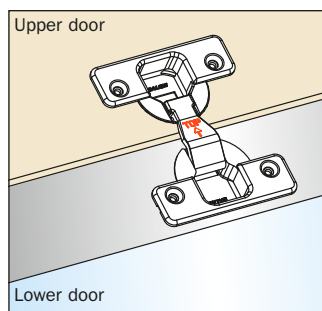
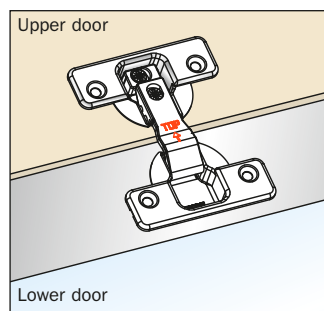

## Fitting the doors to the cabinet

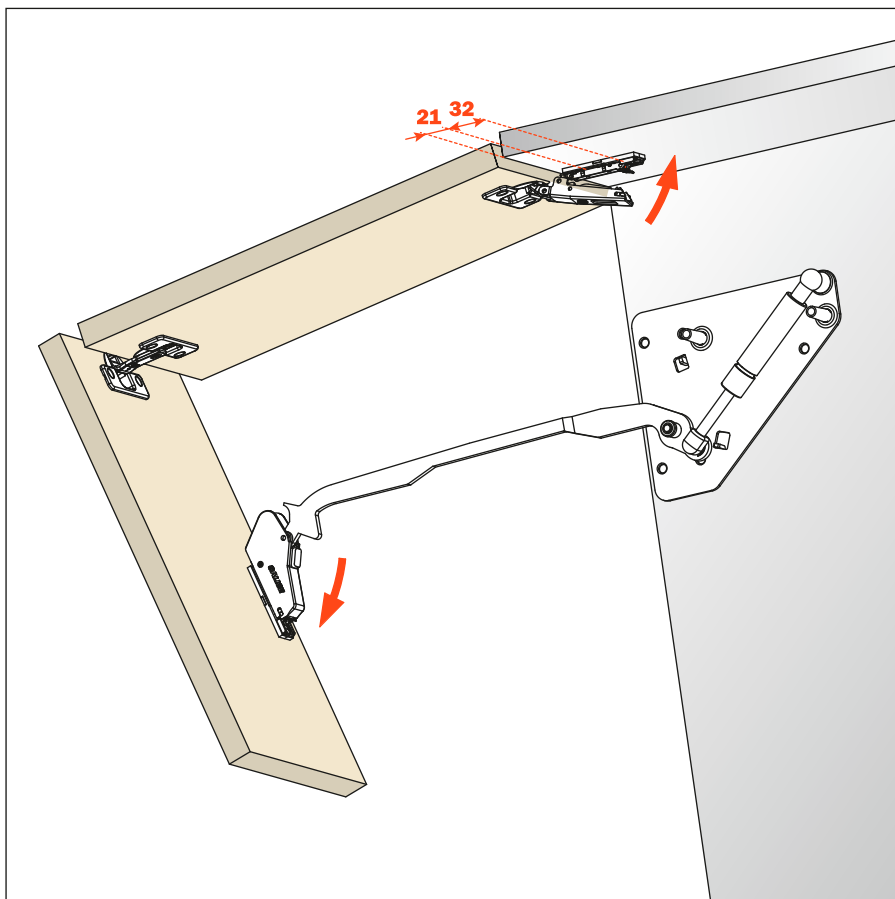

## Installing the cover

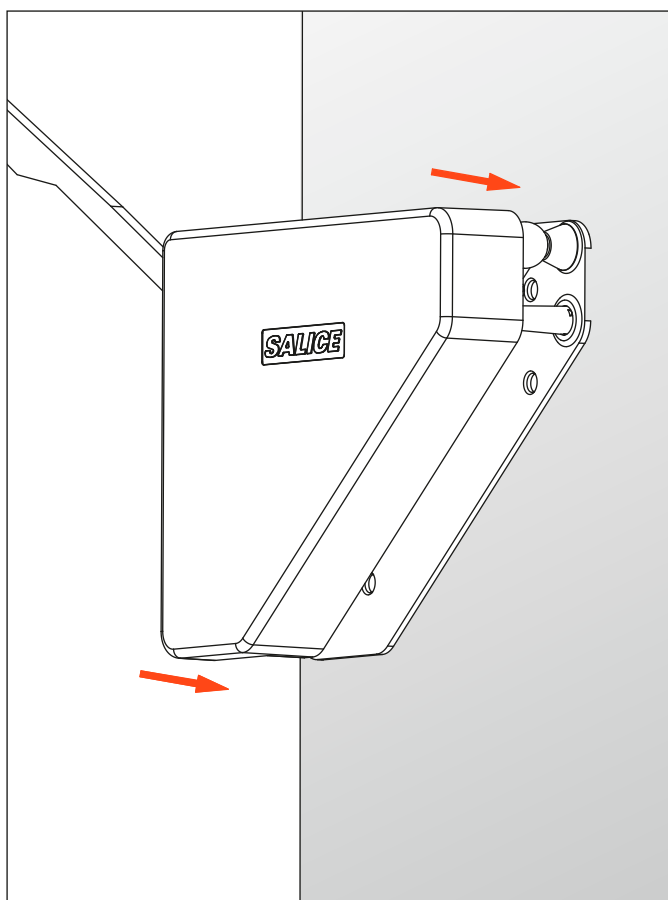

## Dimensions of the system

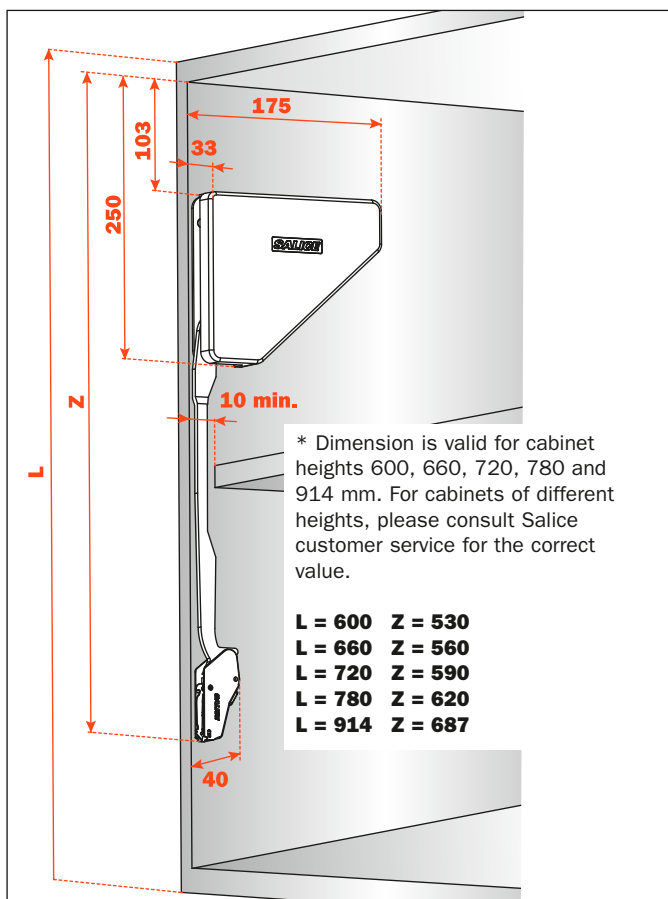

The shape of the lifting arm allows the use of shelves with a reduced depth of 10 mm only compared with the cabinet depth.

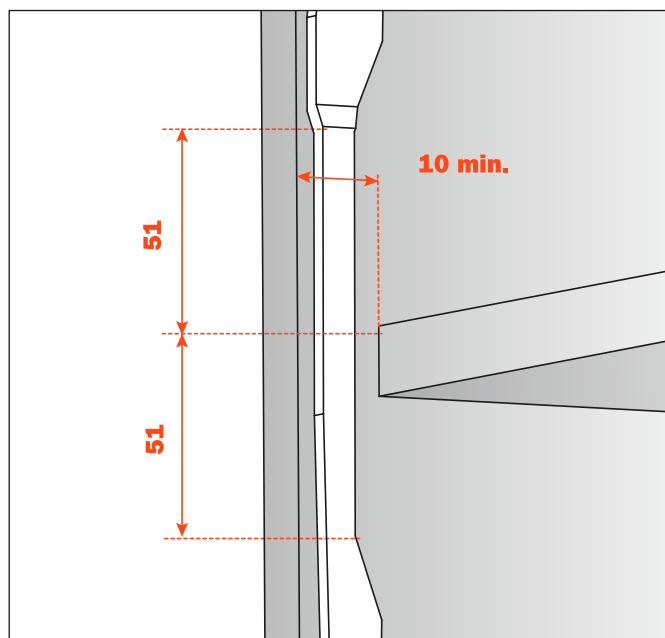

## Replacement of the gas piston

Disconnect the lever arm from the lower door

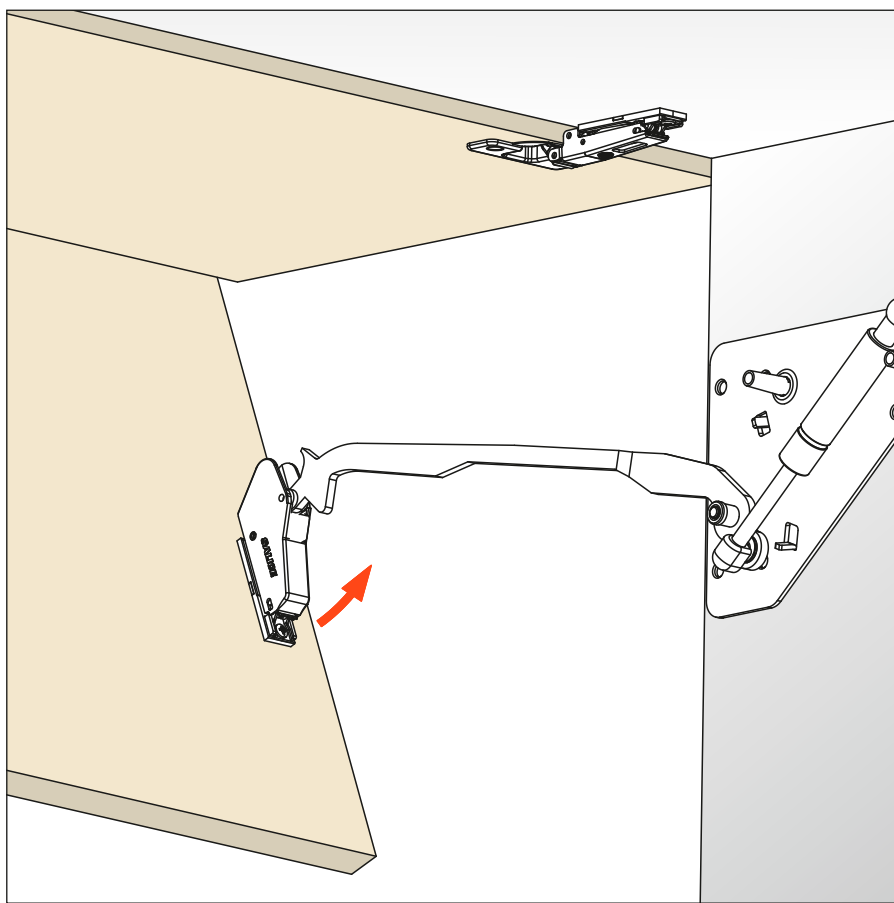

Disconnect the gas piston when it is fully extended

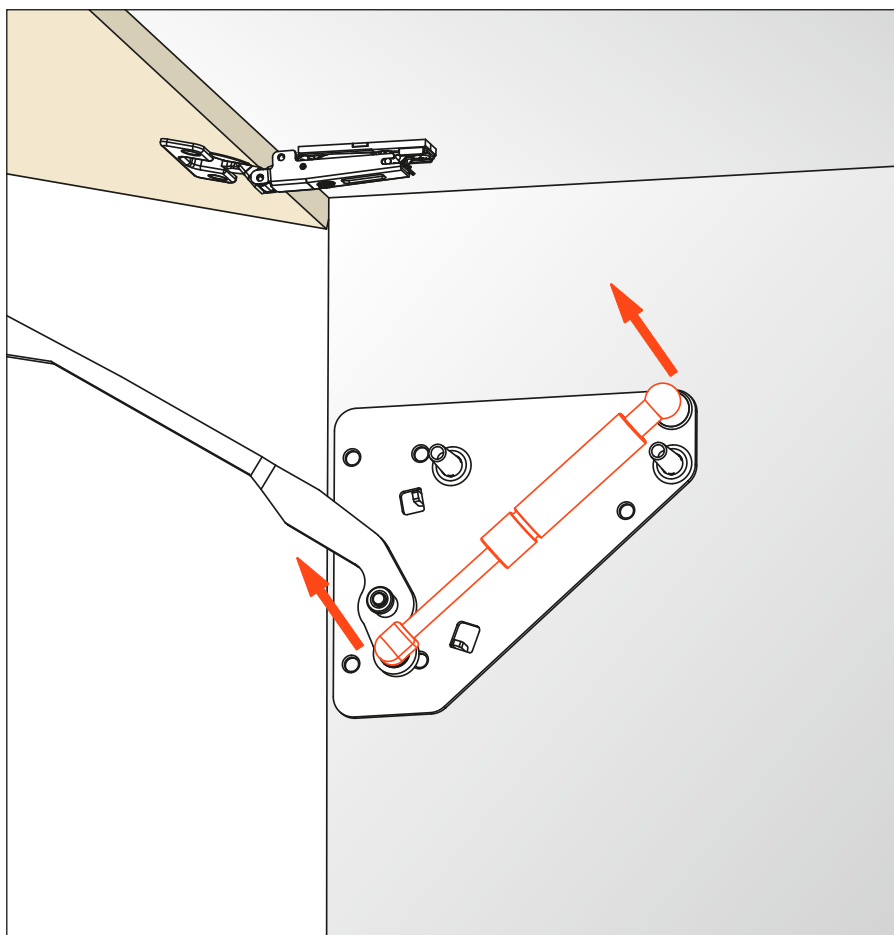



## Chart for FLMGSExxx pistons with single-operation door opening

Chart to define the exact strength of the pistons to be used in relationship with the dimensions and weight of the doors. It is suggested that some assembly trials are made. Our technical assistance service is at your disposal for any additional information. For wall cabinet width 600 mm, it is possible to use one system only, right or left version.

Cabinet width 600, 900 and 1200 mm

Weight of the two doors (Kg)

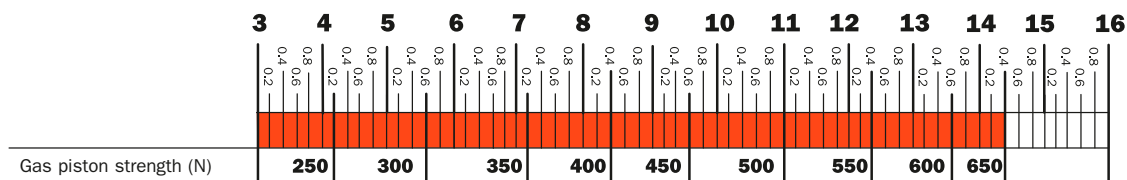

Total height of the two doors 600 mm

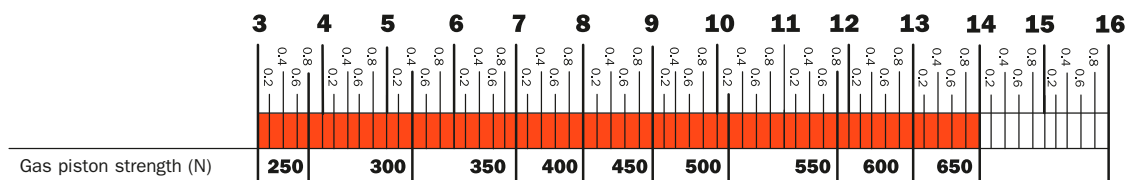

Total height of the two doors 660 mm

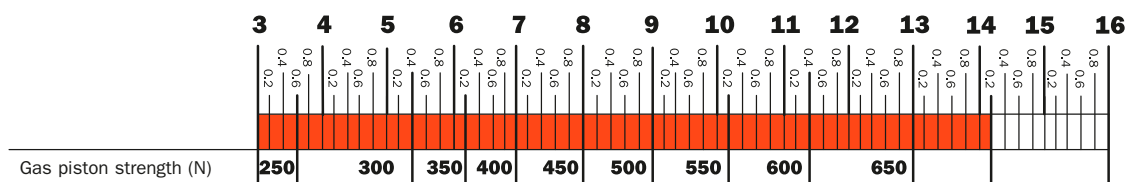

Total height of the two doors 720 mm

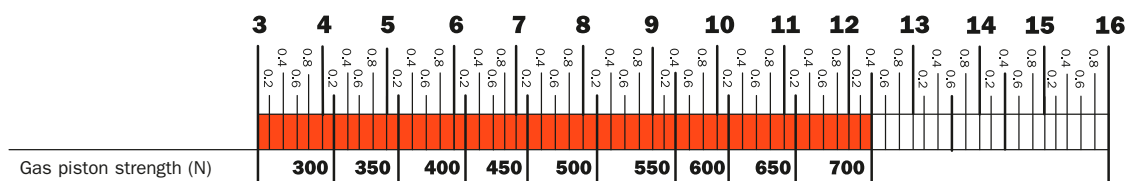

Total height of the two doors 780 mm

## Chart for FLMGRExxx pistons with progressive-operation door opening

Chart to define the exact strength of the pistons to be used in relationship with the dimensions and weight of the doors.  
It is suggested that some assembly trials are made. Our technical assistance service is at your disposal for any additional information.  
For wall cabinet width 600 mm, it is possible to use one system only, right or left version.

Cabinet width 600, 900 and 1200 mm

**Weight of the two doors (Kg)**

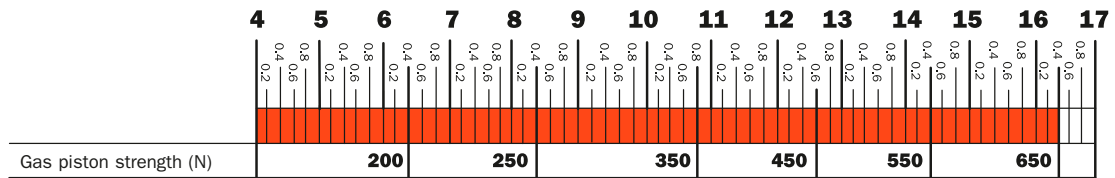

**Total height of the two doors 600 mm**

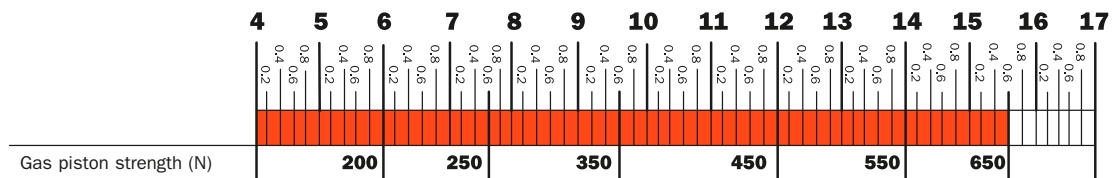

**Total height of the two doors 660 mm**

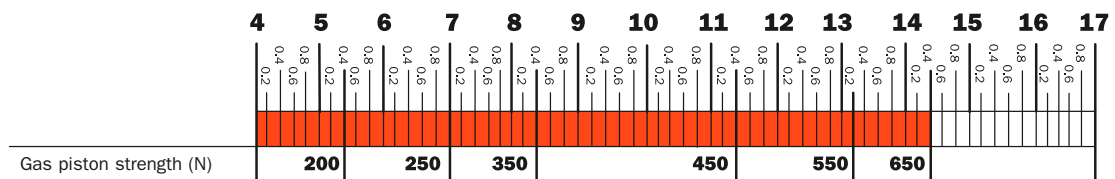

**Total height of the two doors 720 mm**

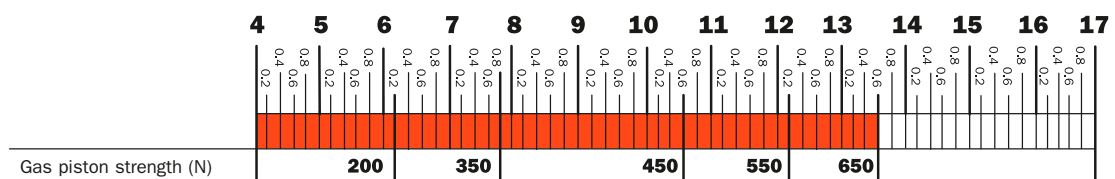

**Total height of the two doors 780 mm**

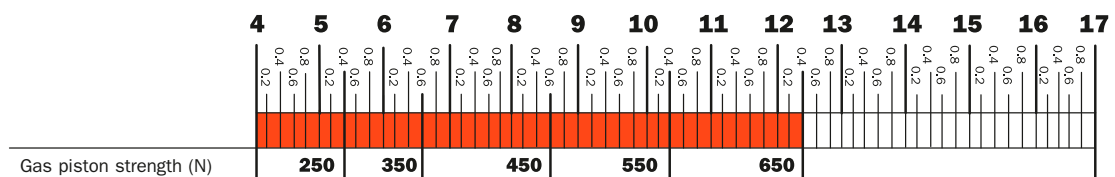

**Total height of the two doors 910 mm**



## Lift - Opening systems - Parallel opening door

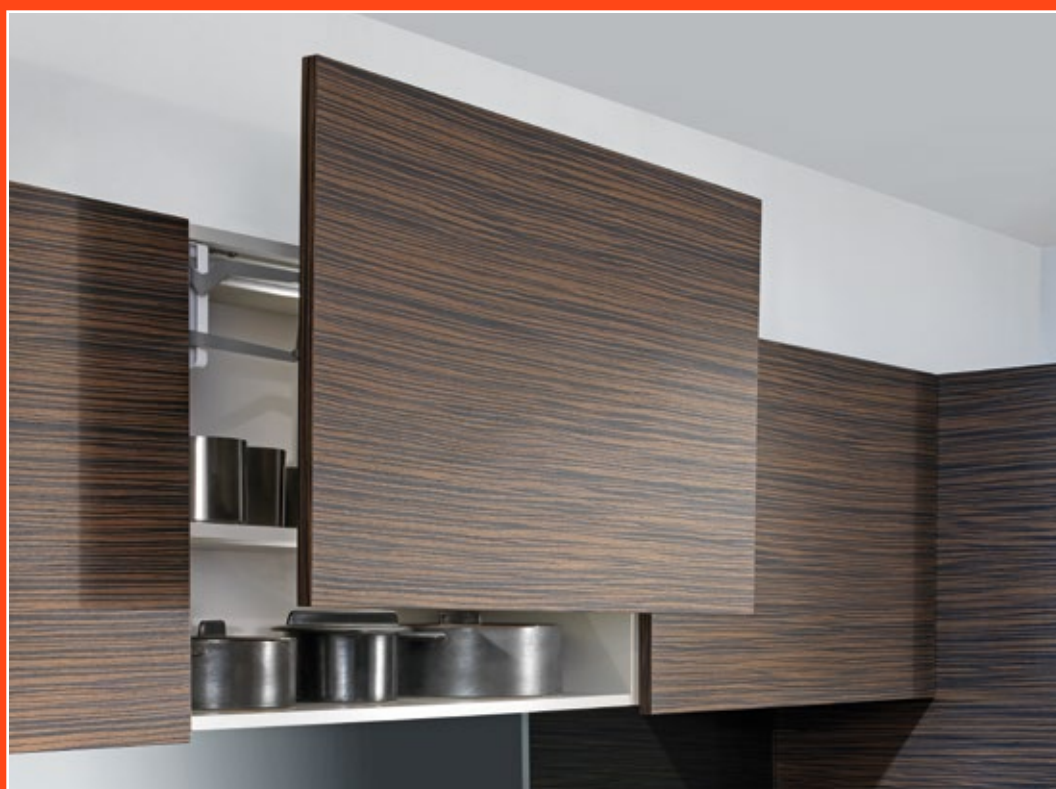

**Lift - Opening systems - Parallel opening door**  
**For doors from 360 mm to 440 mm height**





## Part number composition

**F** = Lifting system

**P** = Parallel opening door

**XXXXXX** = Special options

**SN** = Cover with Salice logo / **99** = Cover with arrangement for screw cover cap

**X** = Colour of the cover

**X1** = Cover with silk-screen printed log

**FPXXXXXS****N****X**

↑  
**G** = grey cover  
**1** = white cover  
**9** = nickel-pl. cover



**FPXXXXX999**

Part number for Lift system supplied with nickel-plated cover with arrangement for screw cover cap.

Screw cover cap to be ordered separately.



**FPXXXXX\_9X1**

Part number for Lift system supplied with nickel-plated cover with silk-screen printed logo.



# Lift - Opening systems - Parallel opening door

## For doors from 360 mm to 440 mm height



### Components of the system for wooden door



#### FPXXXXXXSNX

Lifting system - **right** side

Lifting system - **left** side

Cover

#### Colour of the cover:

G = grey  
1 = white  
9 = nickel-pl.

#### Packing

Boxes 6 pairs

### To be ordered separately:

#### BAPGR39

Mounting plate for door



#### Packing

Boxes 300 pcs.

#### D00SSNG

For doors of small weight and dimensions.



#### Packing

Boxes 250 pcs.

#### FLMGSE **XXX** ← Fill with the required piston strength



Gas piston.  
See page 337 to complete the part number with the appropriate piston strength.

#### Packing

Boxes 12 pcs.

#### D00FSNG

Smove

For doors of middle weight and dimensions.



#### Packing

Boxes 250 pcs.

#### FLMGRE **XXX** ← Fill with the required piston strength



Progressive gas piston.  
See page 337 to complete the part number with the appropriate piston strength.

#### Packing

Boxes 12 pcs.

#### D00LSNG

Smove

For doors of large weight and dimensions.



#### Packing

Boxes 250 pcs.

### Stabilizer bar



**FPX59KX457** for door width 600 mm  
**FPX59KX757** for door width 900 mm  
**FPX59K1057** for door width 1200 mm

#### Packing

Boxes 6 pcs.



## Components of the system for alu-framed door



### FPXXXXXXSNX

Lifting system - **right** side

Lifting system - **left** side

Cover

#### Colour of the cover:

G = grey  
1 = white  
9 = nickel-pl.

#### Packing

Boxes 6 pairs

### To be ordered separately:

#### BAP3R39

Mounting plate for door



#### Packing

Boxes 300 pcs.

#### D00SSNG

Smove

For doors of small weight and dimensions.



#### Packing

Boxes 250 pcs.

#### FLMGSE **XXX** ← Fill with the required piston strength



Gas piston.  
See page 337 to complete the part number with the appropriate piston strength.

#### Packing

Boxes 12 pcs.

#### D00FSNG

Smove

For doors of middle weight and dimensions.



#### Packing

Boxes 250 pcs.

#### FLMGRE **XXX** ← Fill with the required piston strength



Progressive gas piston.  
See page 337 to complete the part number with the appropriate piston strength.

#### Packing

Boxes 12 pcs.

#### D00LSNG

Smove

For doors of large weight and dimensions.



#### Packing

Boxes 250 pcs.

#### DBZXBH9

Support for plate with fixing screws.



#### Packing

Boxes 150 pcs.

#### Stabilizer bar



**FPXX59KX457** for door width 600 mm  
**FPXX59KX757** for door width 900 mm  
**FPXX59K1057** for door width 1200 mm

#### Packing

Boxes 6 pcs.

# Lift - Opening systems - Parallel opening door For doors from 440 mm to 660 mm height



## Part number composition

- F** = Lifting system
- P** = Parallel opening door
- XXXXXX** = Special options
- SN** = Cover with Salice logo / **99** = Cover with arrangement for screw cover cap
- X** = Colour of the cover
- L** = Long arm
- X1** = Cover with silk-screen printed logo

**FPXXXXXS<sup>X</sup>N<sup>X</sup>L**

↑

**G** = grey cover  
**1** = white cover  
**9** = nickel-pl. cover



FPXXXXX**99**9L

Part number for LIFT system supplied with nickel-plated cover with arrangement for screw cover cap.



FPXXXXX\_ **9LX1**

Part number for LIFT system supplied with nickel-plated cover with silk-screen printed logo.



## Components of the system for wooden door



### FPXXXXXXSNXL

Lifting system - **right** side

Lifting system - **left** side

Cover.

#### Colour of the cover:

G = grey  
1 = white  
9 = nickel-pl.

#### Packing

Boxes 6 pairs

### To be ordered separately:

#### BAPGR39

Mounting plate for door



#### Packing

Boxes 300 pcs.

#### D00SSNG

Smove

For doors of small weight and dimensions.



#### Packing

Boxes 250 pcs.

#### FLMGSE **XXX** ← Fill with the required piston strength



Gas piston.  
See page 338 to complete the part number with the appropriate piston strength.

#### Packing

Boxes 12 pcs.

#### D00FSNG

Smove

For doors of middle weight and dimensions.



#### Packing

Boxes 250 pcs.

#### FLMGRE **XXX** ← Fill with the required piston strength



Progressive gas piston.  
See page 339 to complete the part number with the appropriate piston strength.

#### Packing

Boxes 12 pcs.

#### D00LSNG

Smove

For doors of large weight and dimensions.



#### Packing

Boxes 250 pcs.

### Stabilizer bar



**FPX59KX457** for door width 600 mm  
**FPX59KX757** for door width 900 mm  
**FPX59K1057** for door width 1200 mm

#### Packing

Boxes 6 pcs.



# Lift - Opening systems - Parallel opening door

## For doors from 440 mm to 660 mm height



### Components of the system for alu-framed door

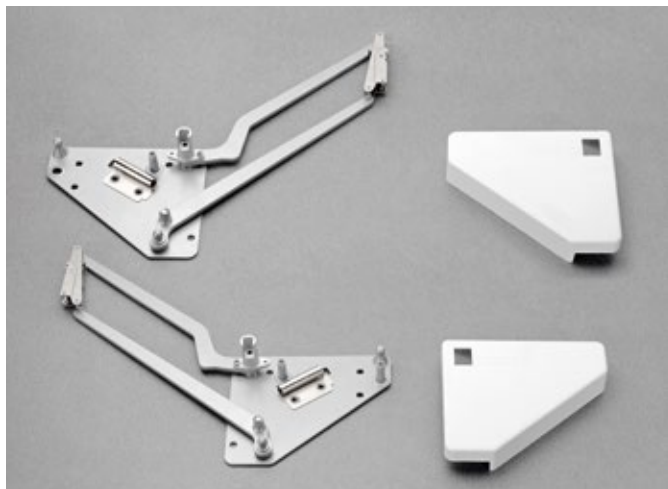

#### FPXXXXXXSNXL

Lifting system - **right** side

Lifting system - **left** side

Cover

#### Colour of the cover:

G = grey  
1 = white  
9 = nickel-pl.

#### Packing

Boxes 6 pairs

### To be ordered separately:

#### BAP3R39

Mounting plate for door



#### Packing

Boxes 300 pcs.

#### D00SSNG

Smove

For doors of small weight and dimensions.



#### Packing

Boxes 250 pcs.

#### FLMGSE XXX ← Fill with the required piston strength



Gas piston.  
See page 338 to complete the part number with the appropriate piston strength.

#### Packing

Boxes 12 pcs.

#### D00FSNG

Smove

For doors of middle weight and dimensions.



#### Packing

Boxes 250 pcs.

#### FLMGRE XXX ← Fill with the required piston strength



Progressive gas piston.  
See page 339 to complete the part number with the appropriate piston strength.

#### Packing

Boxes 12 pcs.

#### D00LSNG

Smove

For doors of large weight and dimensions.



#### Packing

Boxes 250 pcs.

#### DBZXBH9

Support for plate with fixing screws.



#### Packing

Boxes 150 pcs.

### Stabilizer bar



**FPXX59KX457** for door width 600 mm  
**FPXX59KX757** for door width 900 mm  
**FPXX59K1057** for door width 1200 mm

#### Packing

Boxes 6 pcs.

### Fixing the support to the cabinet side

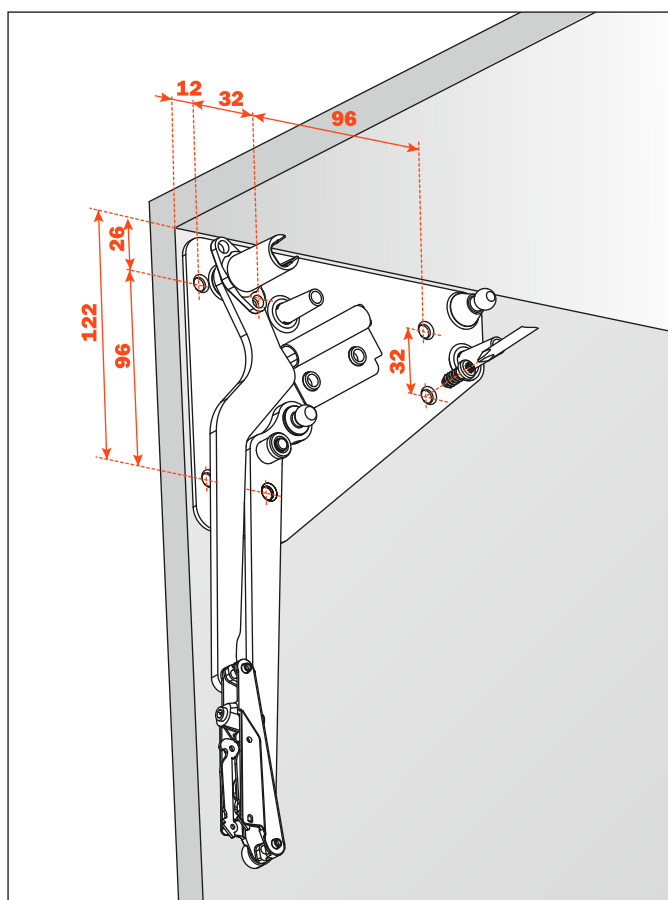

### Deploying the piston

Carefully press each end of the piston securely onto the pins on the bracket and lifting arm, ensuring that the body of the piston is uppermost.

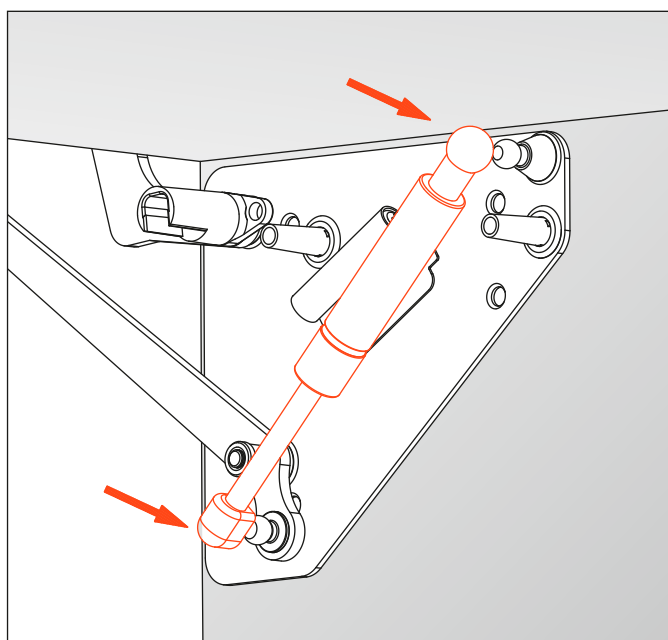



**Installing the Smove**

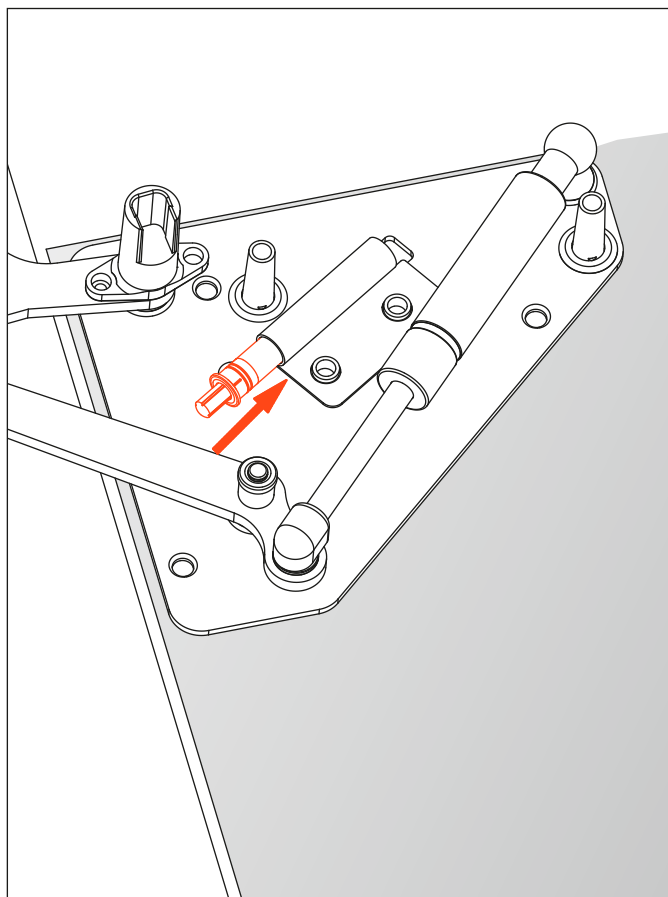

**Installing the cover**

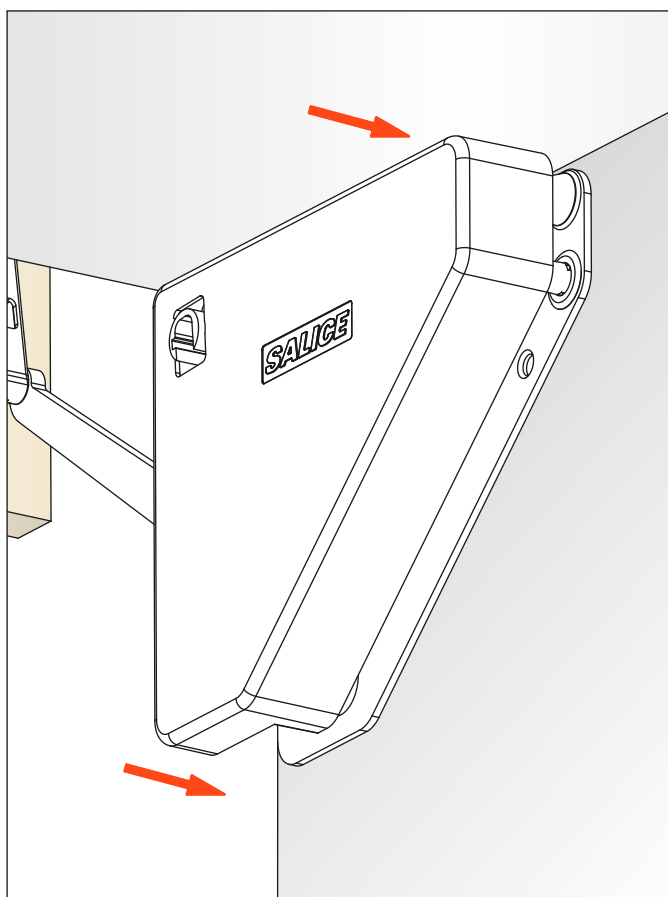

## Fitting the stabilizer bar

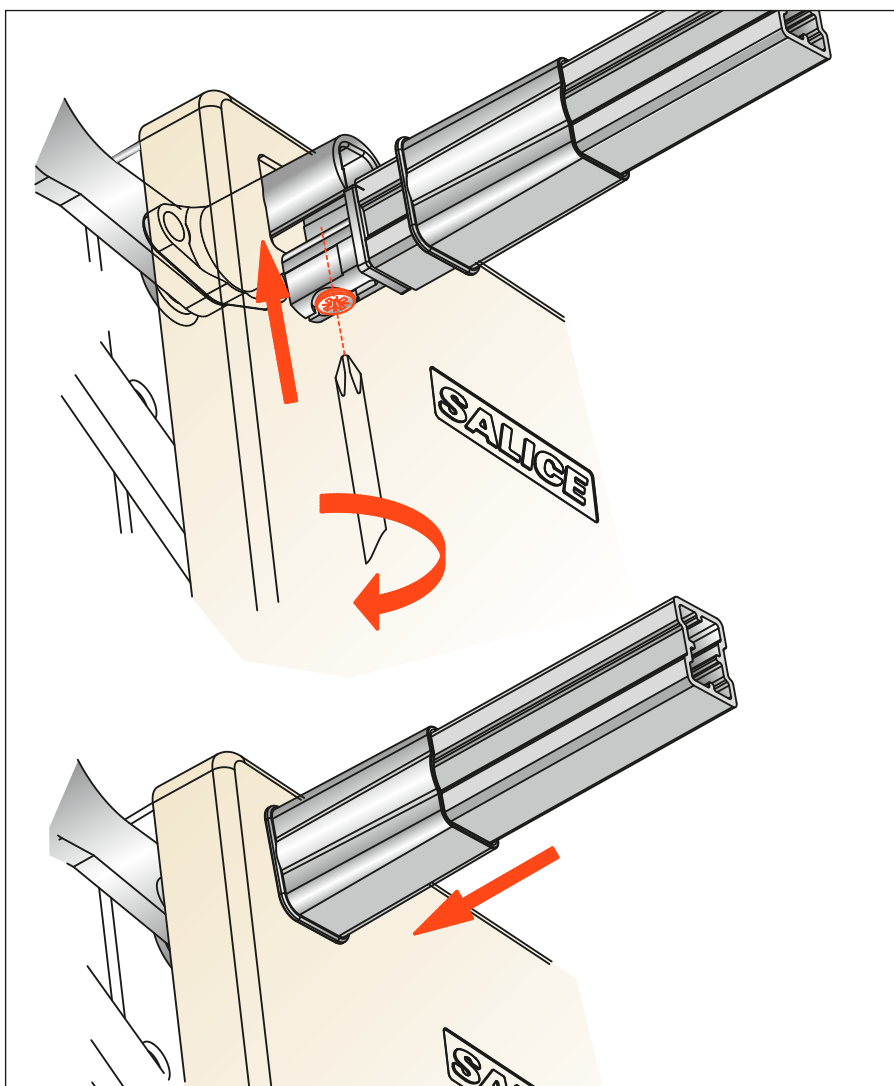

Insert the ends of the bar into the housing and fasten the fixing screw.

Slide the sleeves over the housing at each end of the bar.

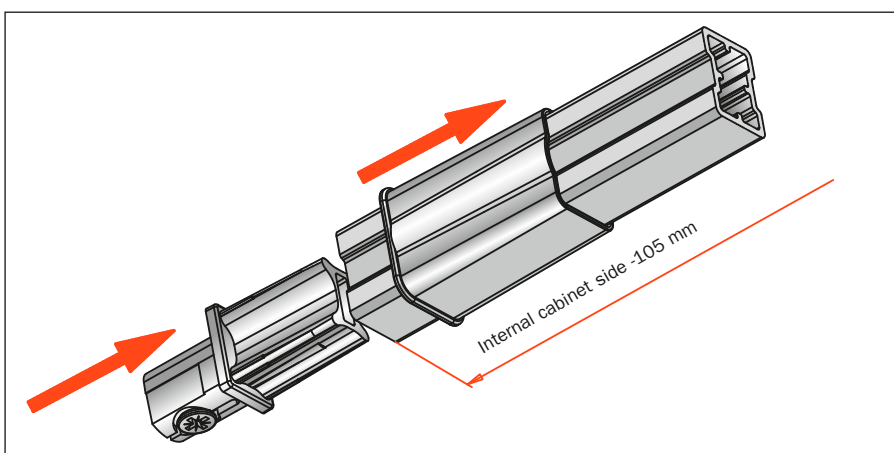

In case of cabinets with special widths, pull the bar end off one side and cut it accordingly. Re-insert the bar end into the housing.

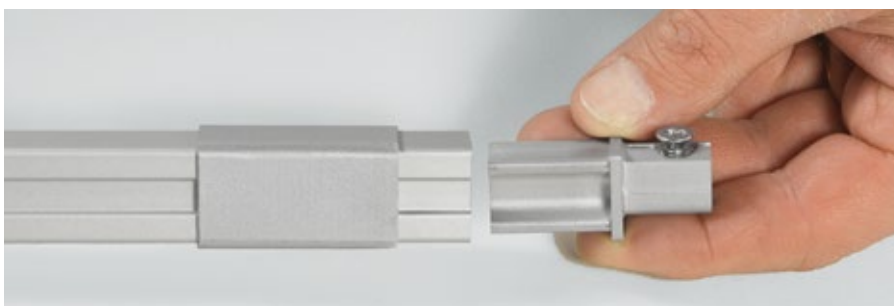

## Drilling pattern for wooden door and alu-framed door For doors from 360 to 440 mm height

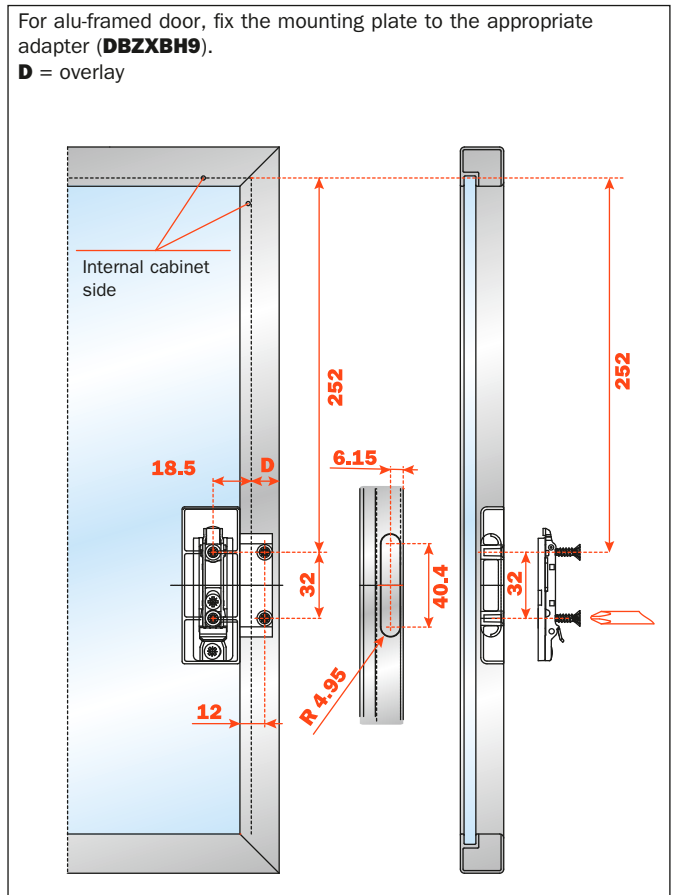
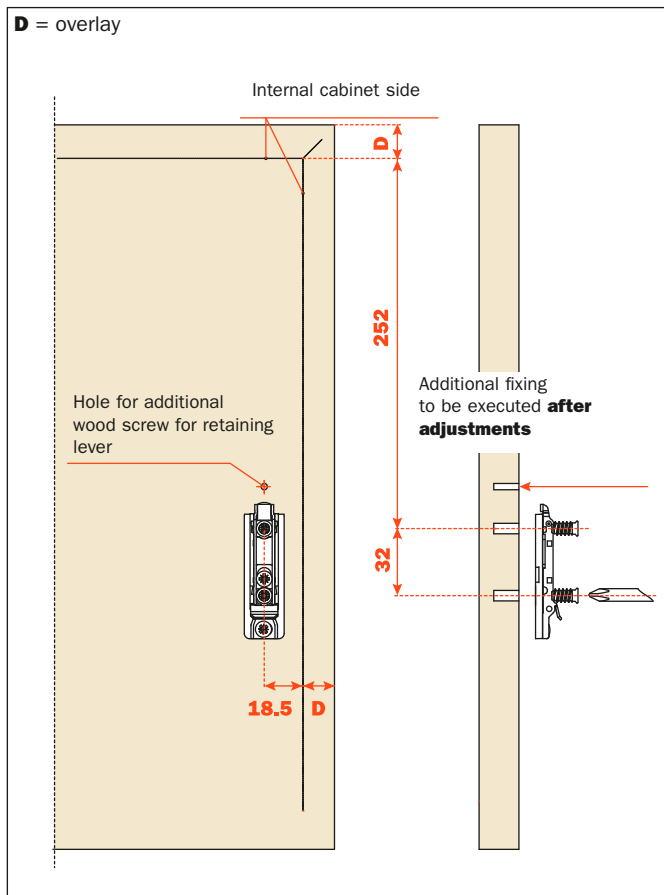

## Drilling pattern for wooden door and alu-framed door For doors from 440 to 660 mm height.

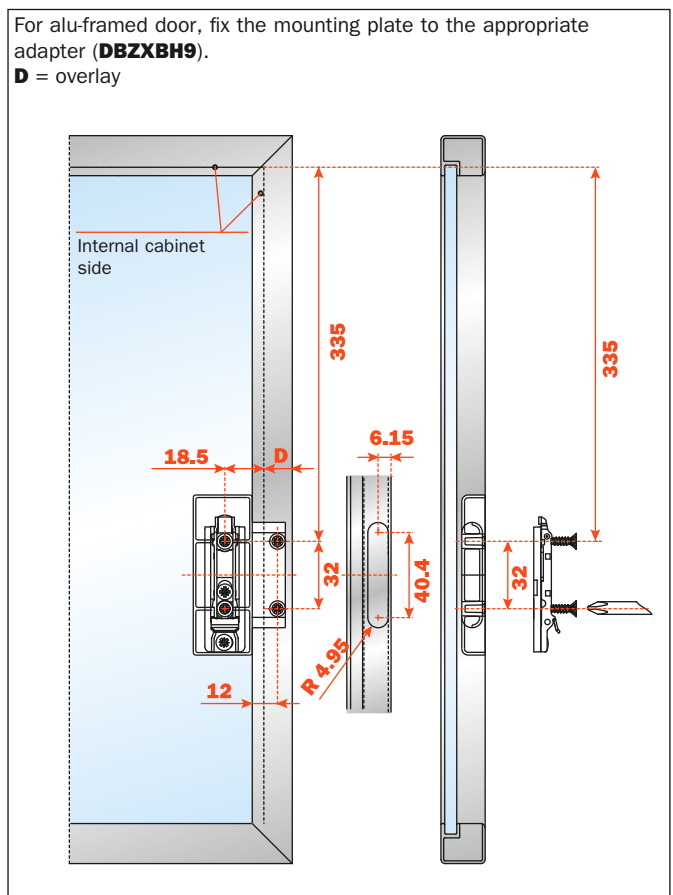
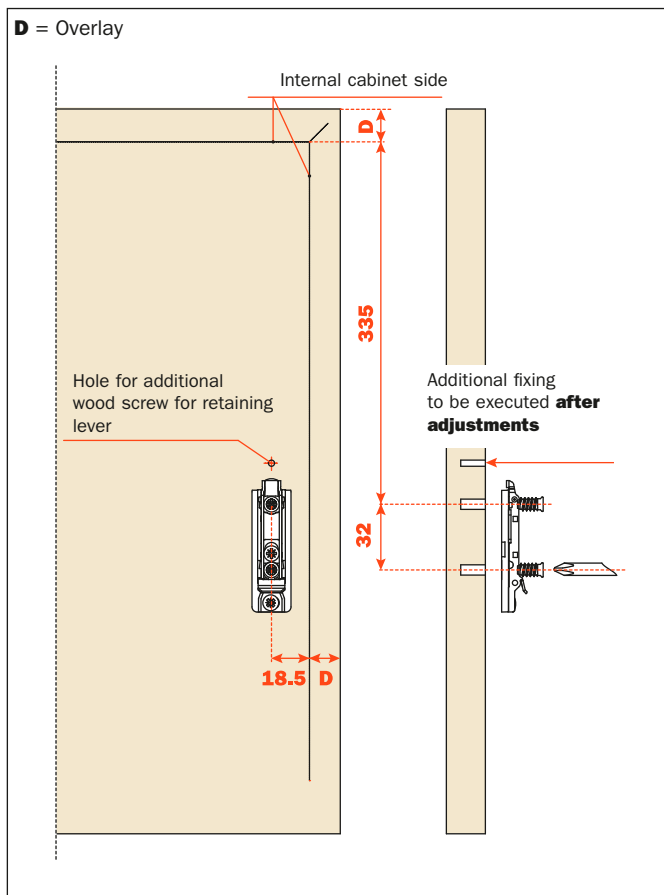

## Fitting the door to the cabinet

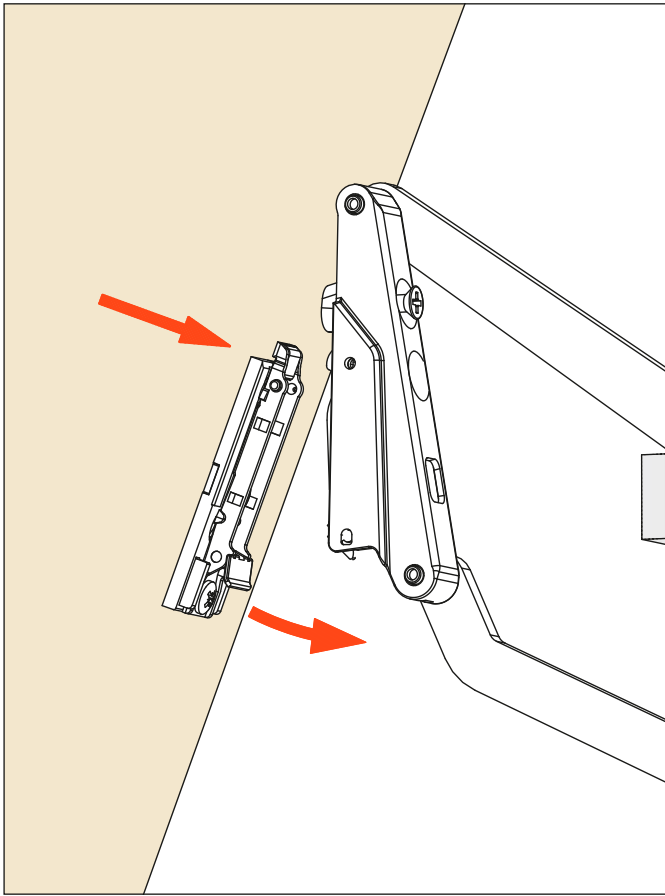

## Adjustments and additional fixing

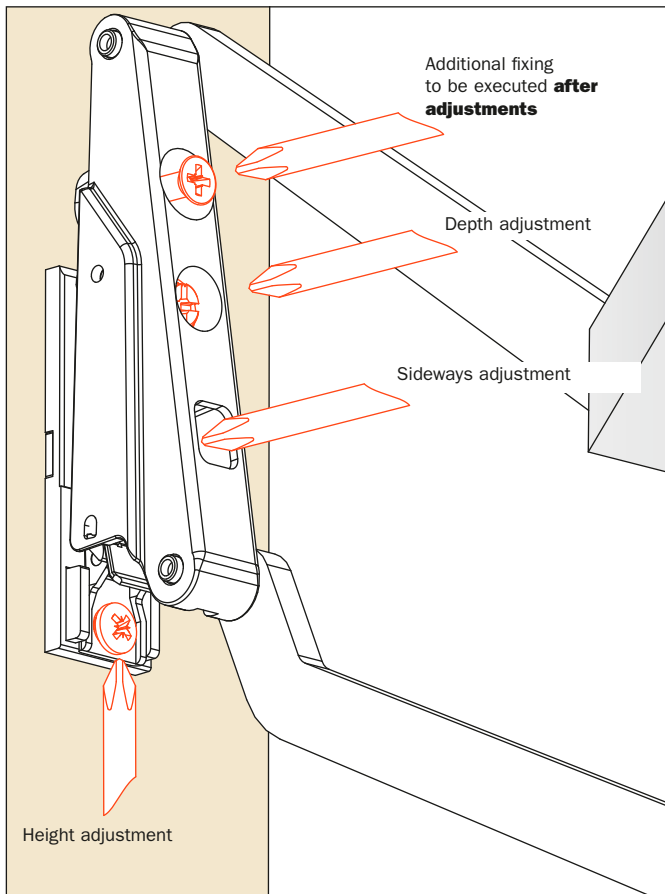

## Dimensions of the system for doors from 360 to 440 mm height

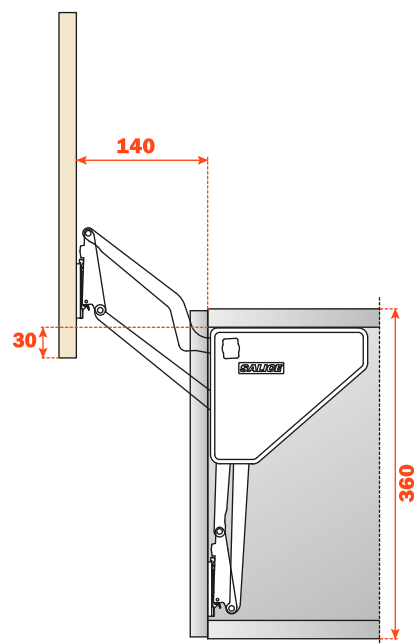
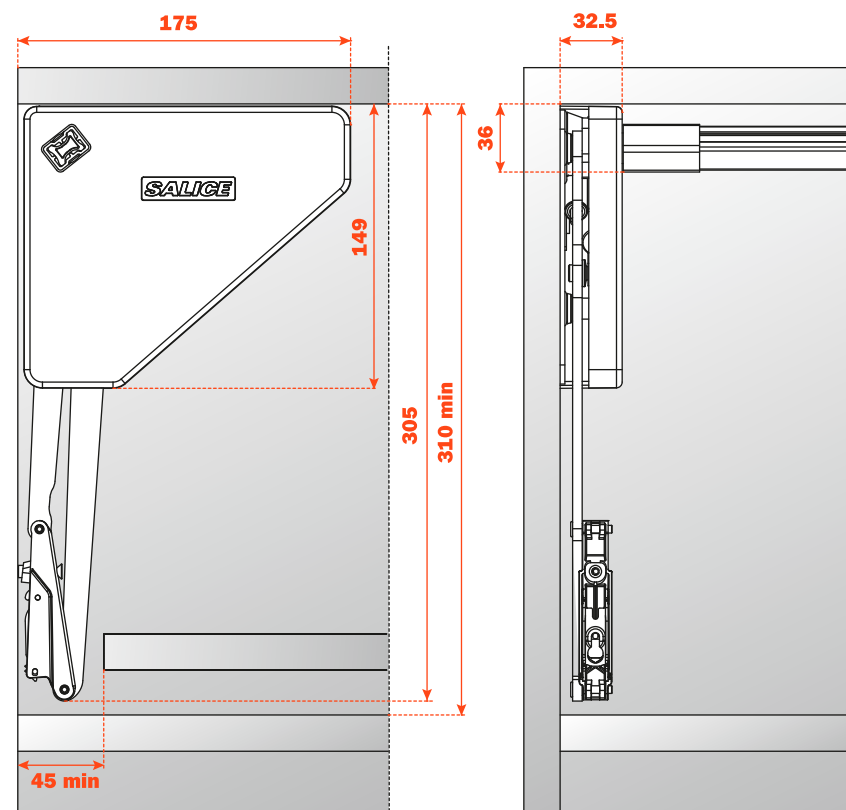

## Dimensions of the system for doors from 440 to 660 mm height

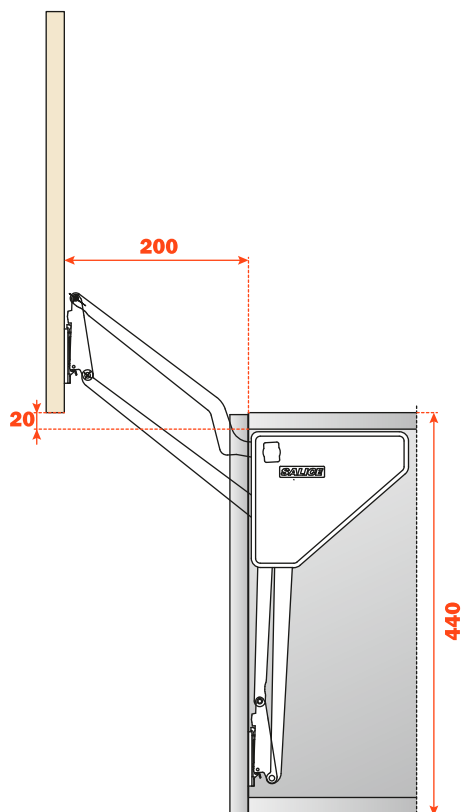
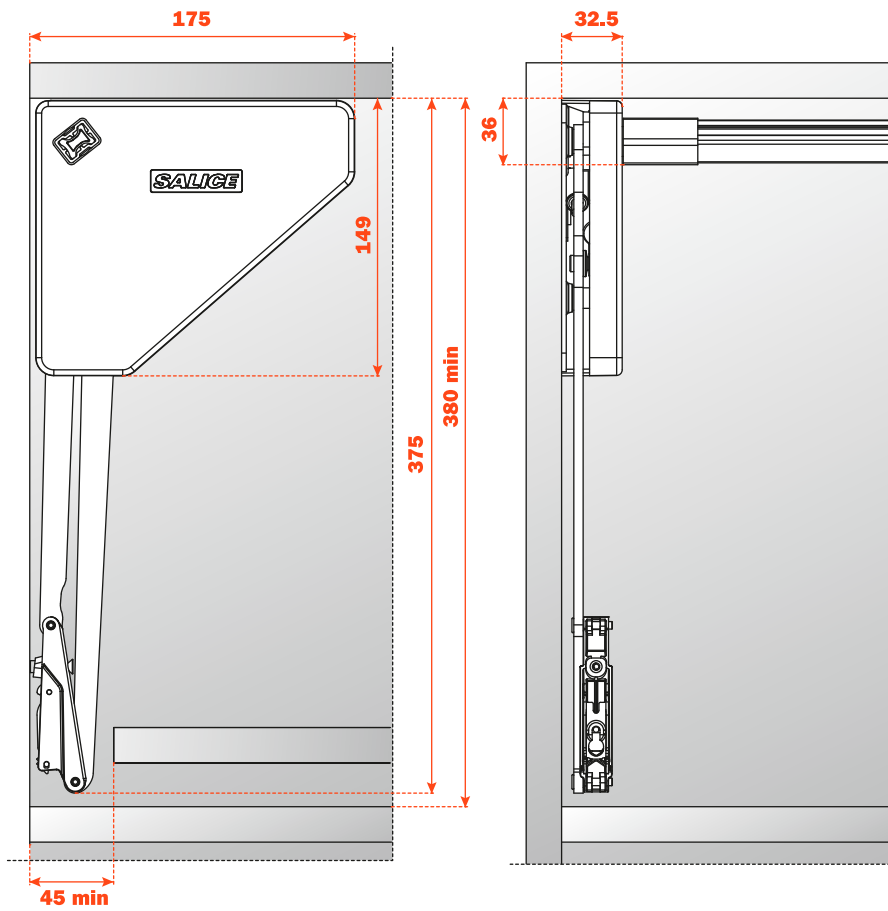



## Disassembly

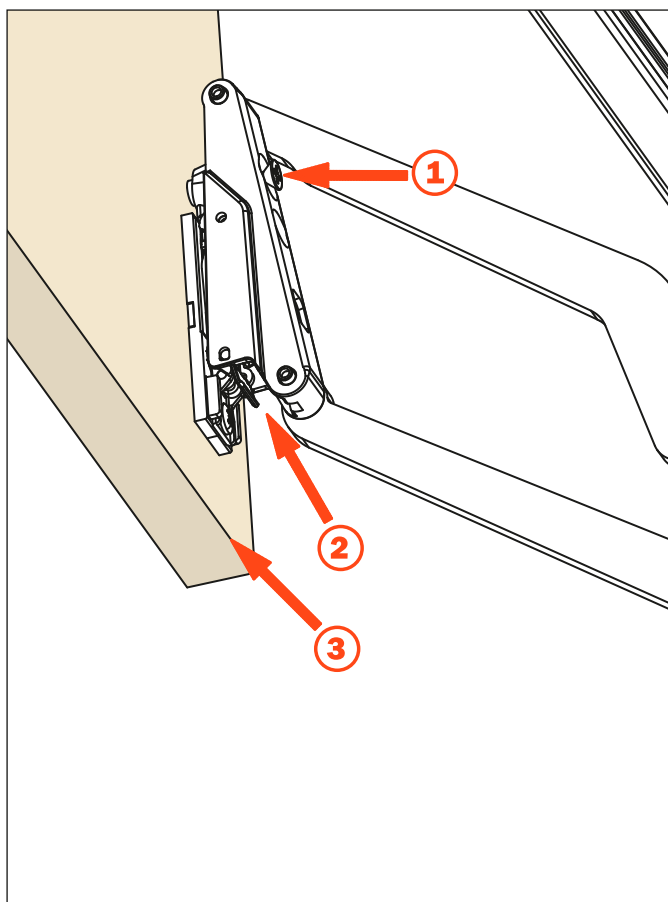

- 1) Loosen the additional wood screw
- 2) then press firmly on the mounting plate lever
- 3) push the door



**Chart for FLMGSExxx pistons with single-operation door opening for doors from 360 to 440 mm height**

Chart to define the exact strength of the pistons to be used in relationship with the dimensions and weight of the doors.

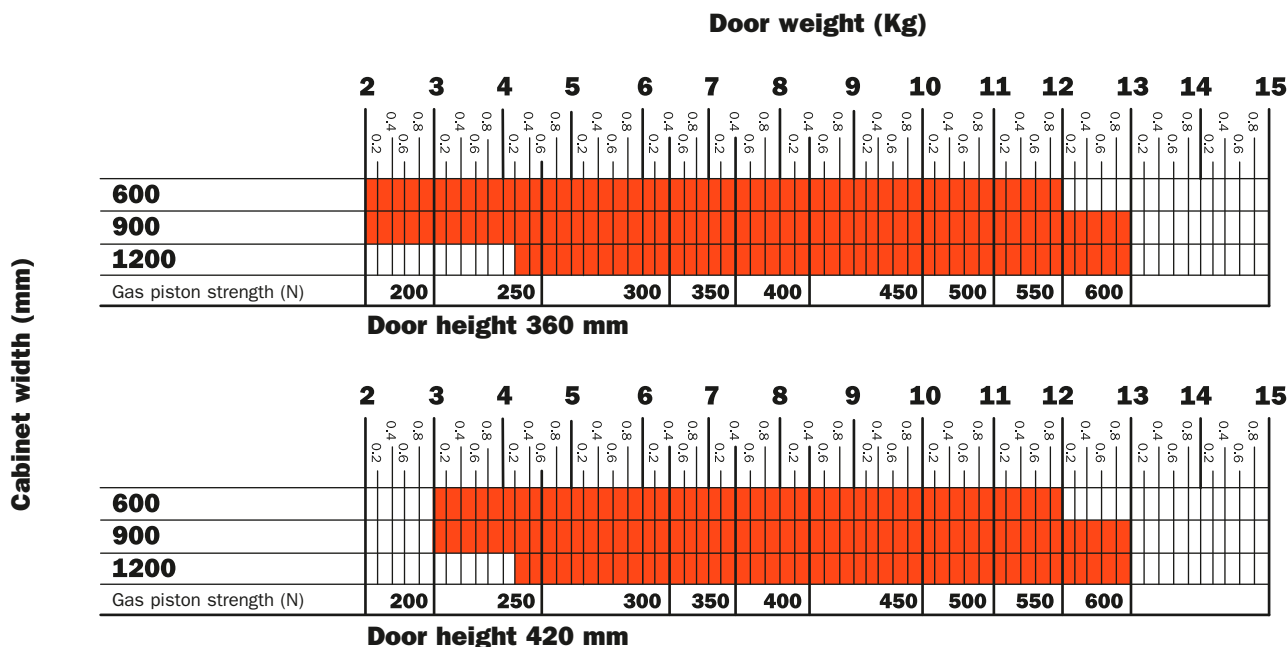

**Chart for FLMGRExxx pistons with progressive-operation door opening for doors from 360 to 440 mm height**

Chart to define the exact strength of the pistons to be used in relationship with the dimensions and weight of the doors.

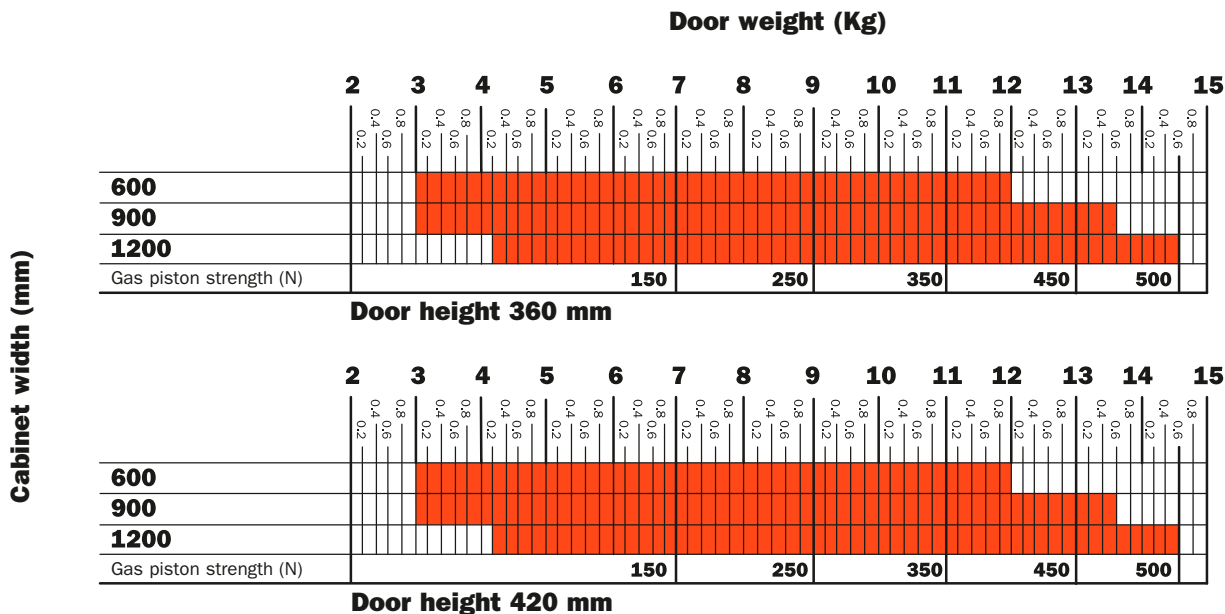

# Lift - Opening systems - Parallel opening door - Gas piston strength

## Chart for FLMGSExxx pistons with single-operation door opening for doors from 440 to 660 mm height.

Chart to define the exact strength of the pistons to be used in relationship with the dimensions and weight of the doors.

Cabinet width (mm)

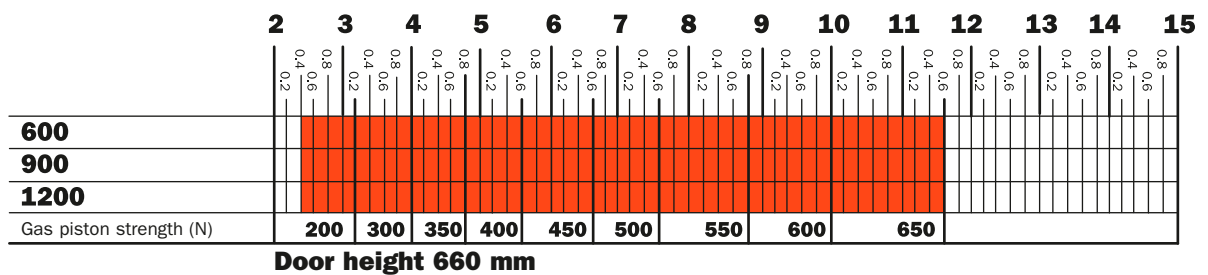
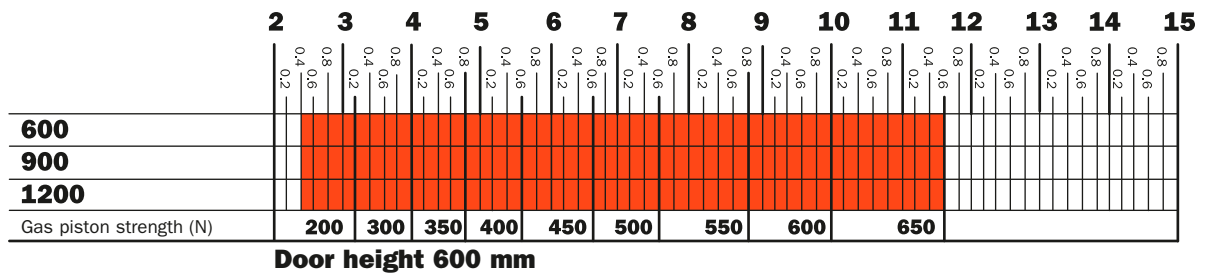
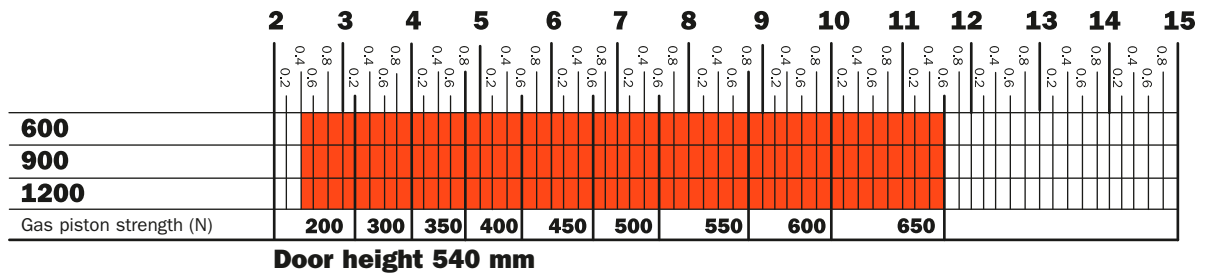
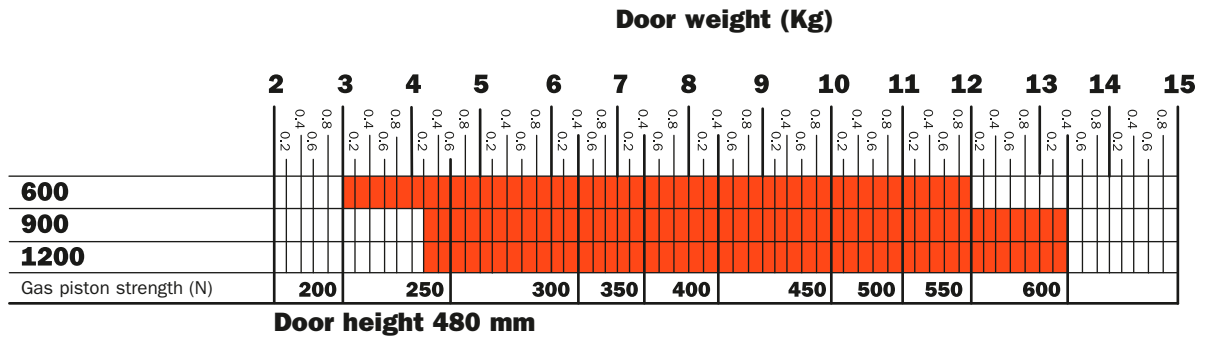

### Chart for FLMGRExxx pistons with progressive-operation door opening for doors from 440 to 660 mm height.

Chart to define the exact strength of the pistons to be used in relationship with the dimensions and weight of the doors.

Cabinet width (mm)

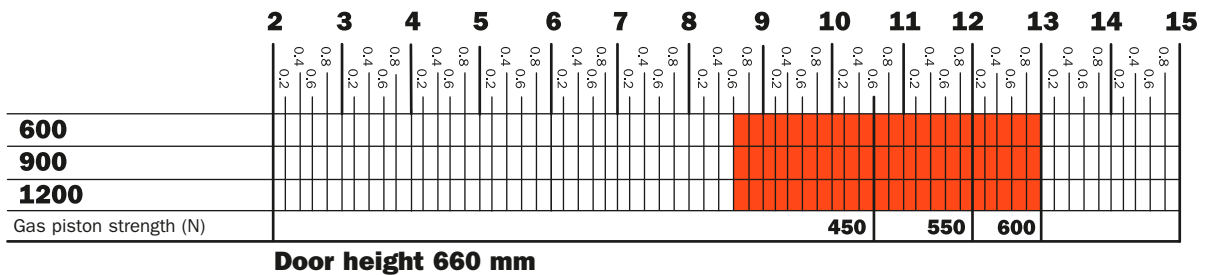
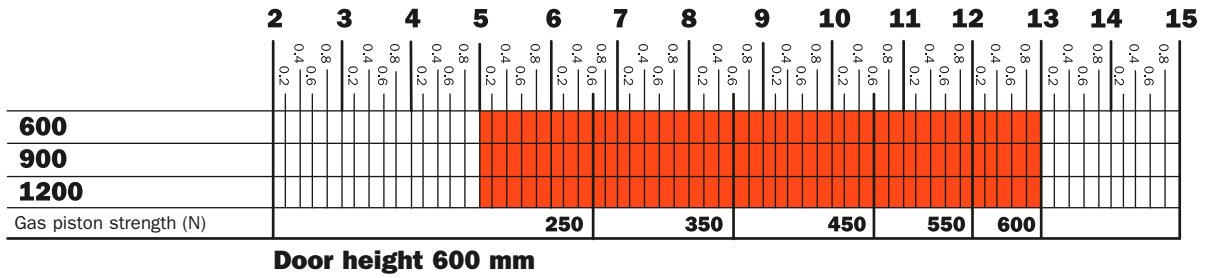
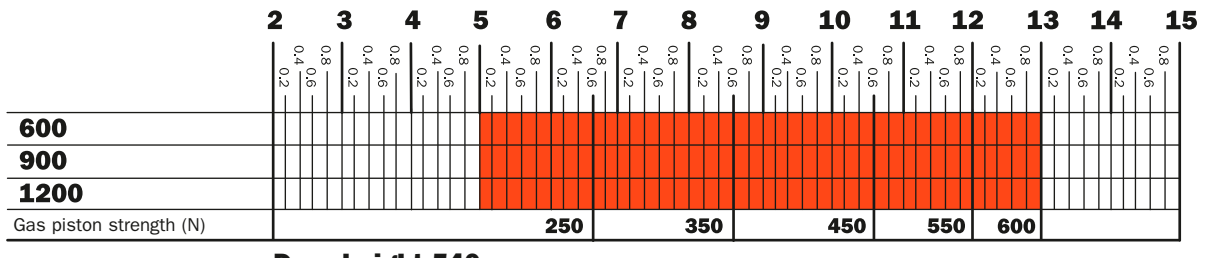
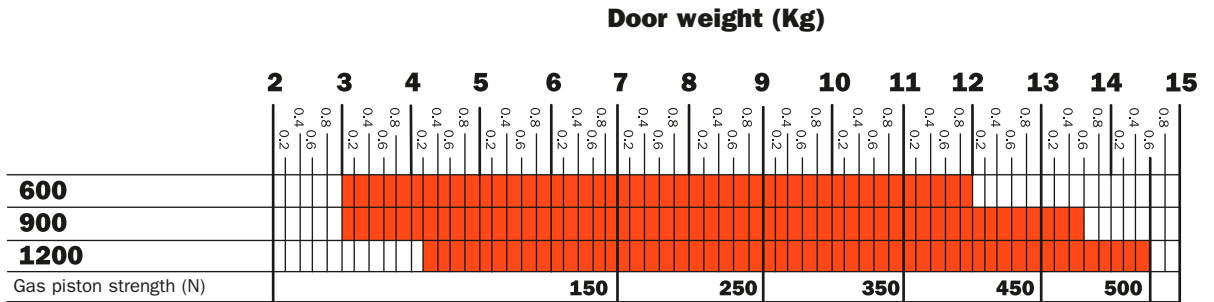



## Lift - Opening systems - Swing opening door







## Part number composition

**F** = Lifting system

**B** = Swing opening door

**XXXXXX** = Special options

**SN** = Cover with Salice logo / **99** = Cover with arrangement for screw cover cap

**X** = Colour of the cover

**X1** = Cover with silk-screen printed logo

**FBXXXXXS****N****X**

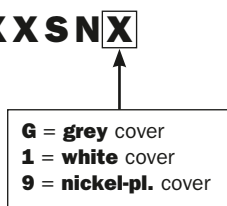

**FBXXXXX999**

Part number for Lift system supplied with nickel-plated cover with arrangement for screw cover cap.

Screw cover cap to be ordered separately.



**FBXXXXX\_9X1**

Part number for Lift system supplied with nickel-plated cover with silk-screen printed logo.



## Components of the system for wooden door

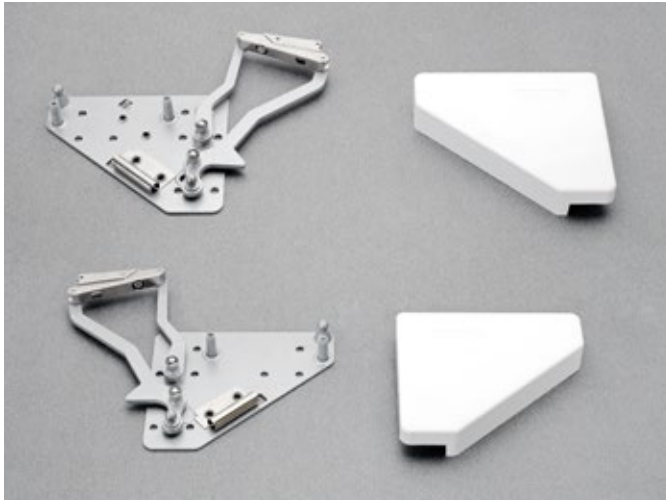

### FBXXXXXXSNX

Lifting system - **right** side

Lifting system - **left** side

Cover

#### Colour of the cover:

G = grey  
1 = white  
9 = nickel-pl.

#### Packing

Boxes 6 pairs

### To be ordered separately:

#### BAPGR39

Mounting plate for door



#### Packing

Boxes 300 pcs.

#### D00SSNG

Smove

For doors of small weight and dimensions.



#### Packing

Boxes 250 pcs.

#### FLMGSE **XXX** ← Fill with the required piston strength

Gas piston.  
See page 351 to complete the part number with the appropriate piston strength.



#### Packing

Boxes 12 pcs.

#### D00FSNG

Smove

For doors of middle weight and dimensions.



#### Packing

Boxes 250 pcs.

#### FLMGRE **XXX** ← Fill with the required piston strength

Progressive gas piston.  
See page 352 to complete the part number with the appropriate piston strength.



#### Packing

Boxes 12 pcs.

#### D00LSNG

Smove

For doors of large weight and dimensions.



#### Packing

Boxes 250 pcs.



## Components of the system for alu-framed door

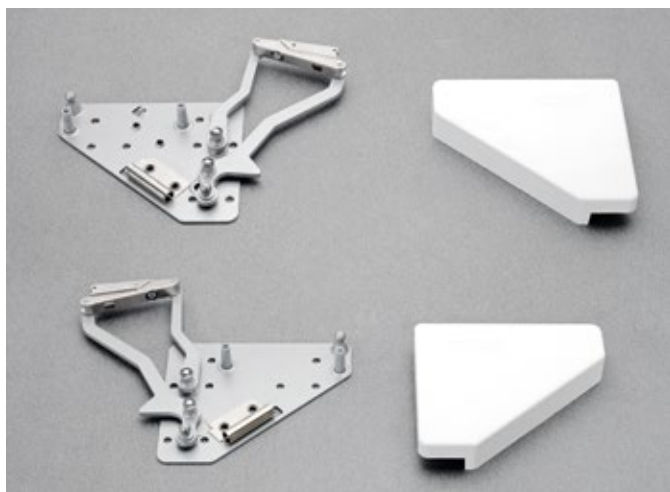

### FBXXXXXXSNX

Lifting system - **right** side

Lifting system - **left** side

Cover

#### Colour of the cover:

G = grey  
1 = white  
9 = nickel-pl.

#### Packing

Boxes 6 pairs

### To be ordered separately:

#### BAP3R39

Mounting plate for door



#### Packing

Boxes 300 pcs.

#### D00SSNG

For doors of small weight and dimensions.



#### Packing

Boxes 250 pcs.

#### FLMGSE **XXX** ← Fill with the required piston strength



Gas piston.  
See page 351 to complete the part number with the appropriate piston strength.

#### Packing

Boxes 12 pcs.

#### D00FSNG

Smove

For doors of middle weight and dimensions.



#### Packing

Boxes 250 pcs.

#### FLMGRE **XXX** ← Fill with the required piston strength



Progressive gas piston.  
See page 352 to complete the part number with the appropriate piston strength.

#### Packing

Boxes 12 pcs.

#### D00LSNG

Smove

For doors of large weight and dimensions.



#### Packing

Boxes 250 pcs.

#### DBZXBH9

Support for plate with fixing screws.



#### Packing

Boxes 150 pcs.

### Fixing the support to the cabinet side

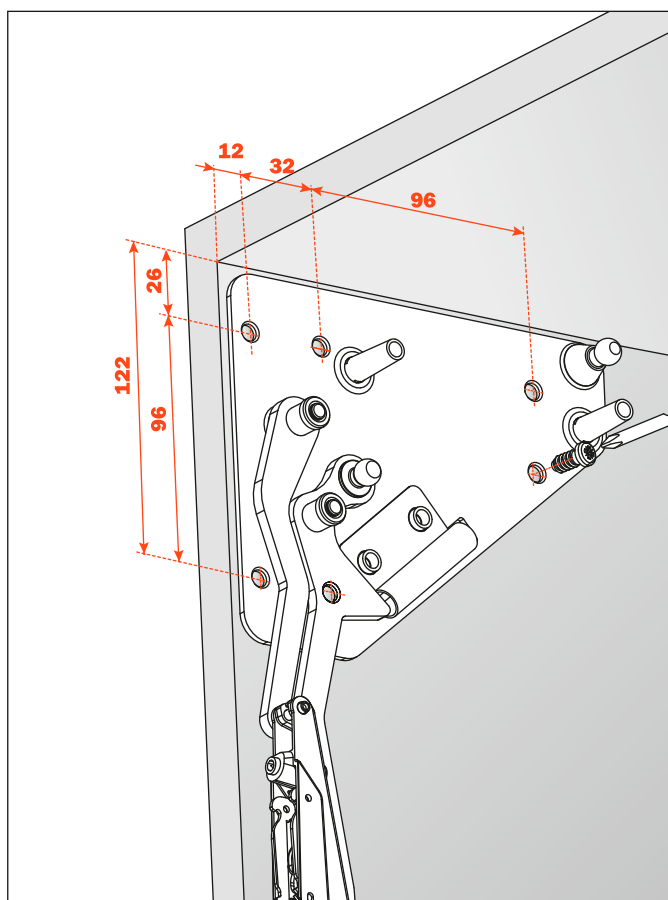

### Deploying the piston

Carefully press each end of the piston securely onto the pins on the bracket and lifting arm, ensuring that the body of the piston is uppermost.

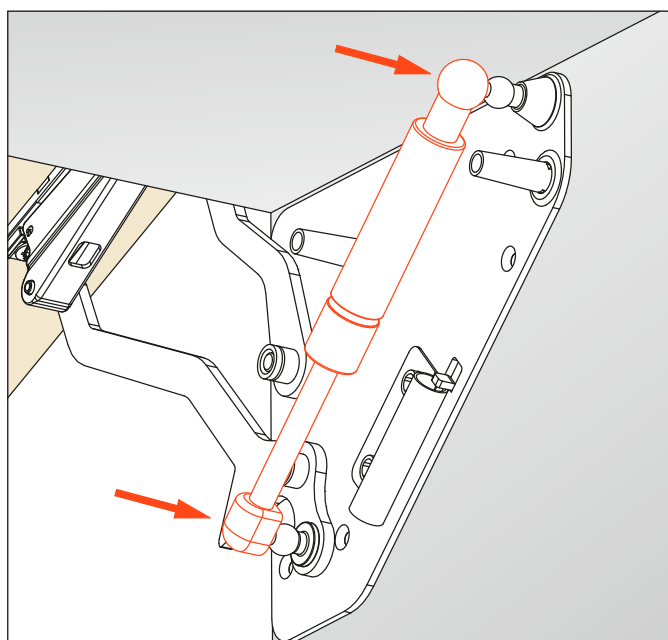



## Installing the Smove

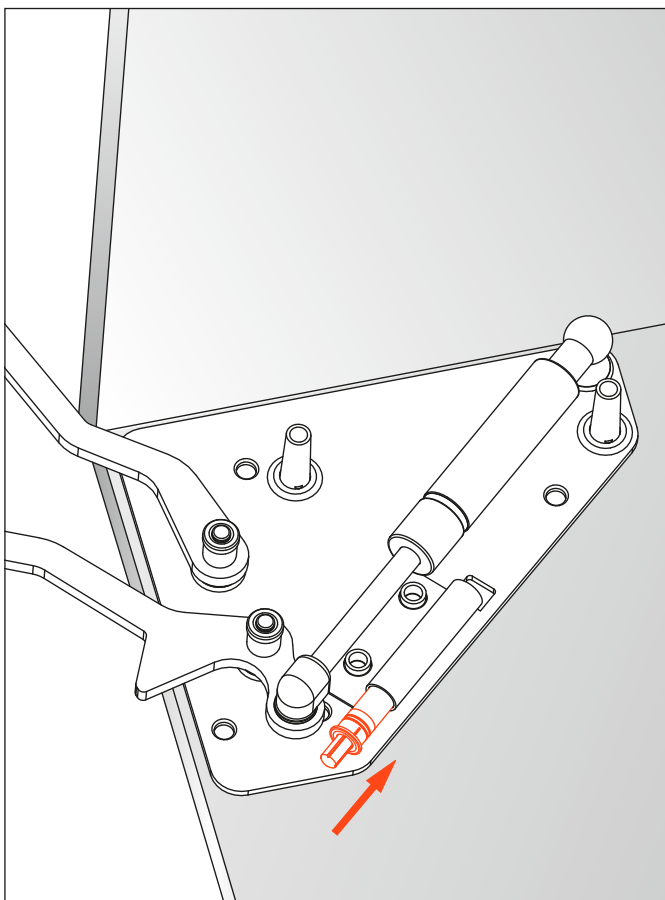

### Drilling pattern for wooden door and alu-framed door

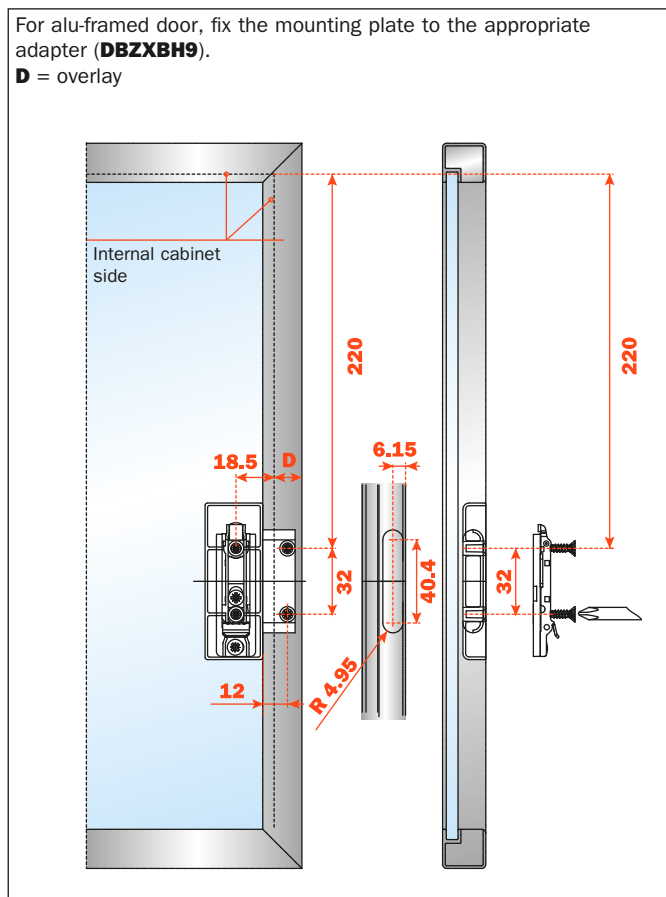
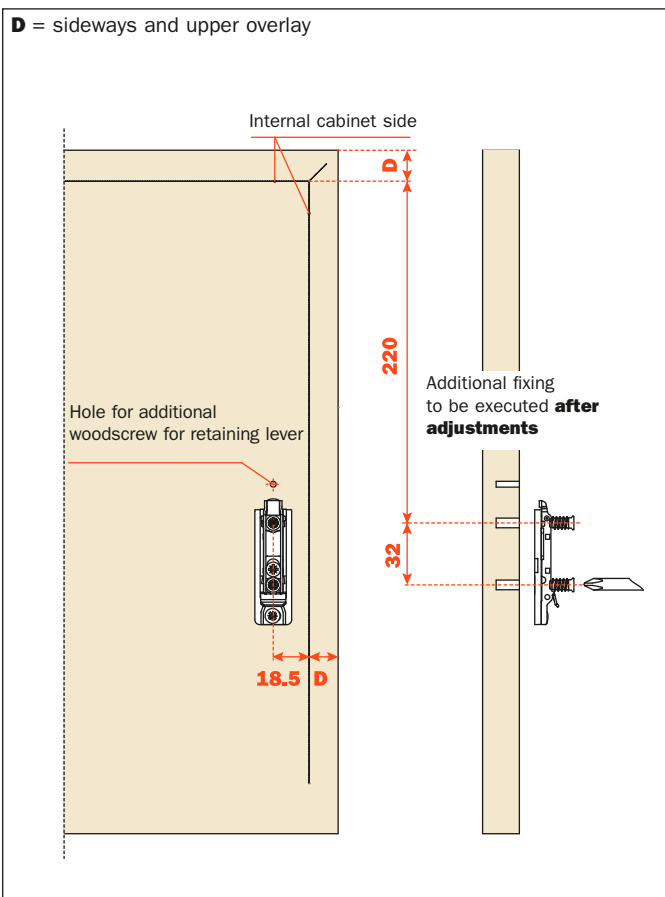

## Fitting the door to the cabinet

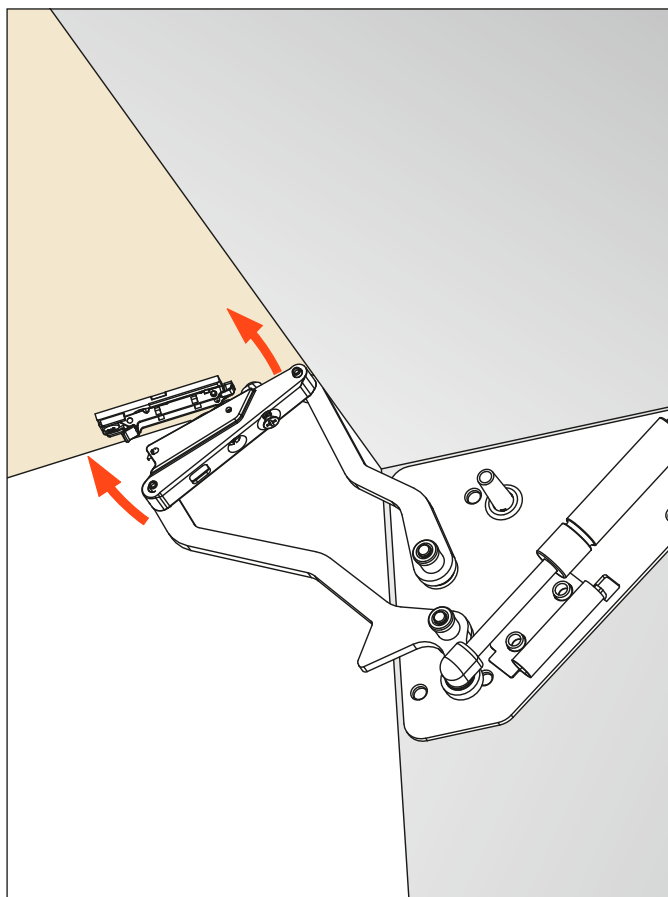

## Installing the cover

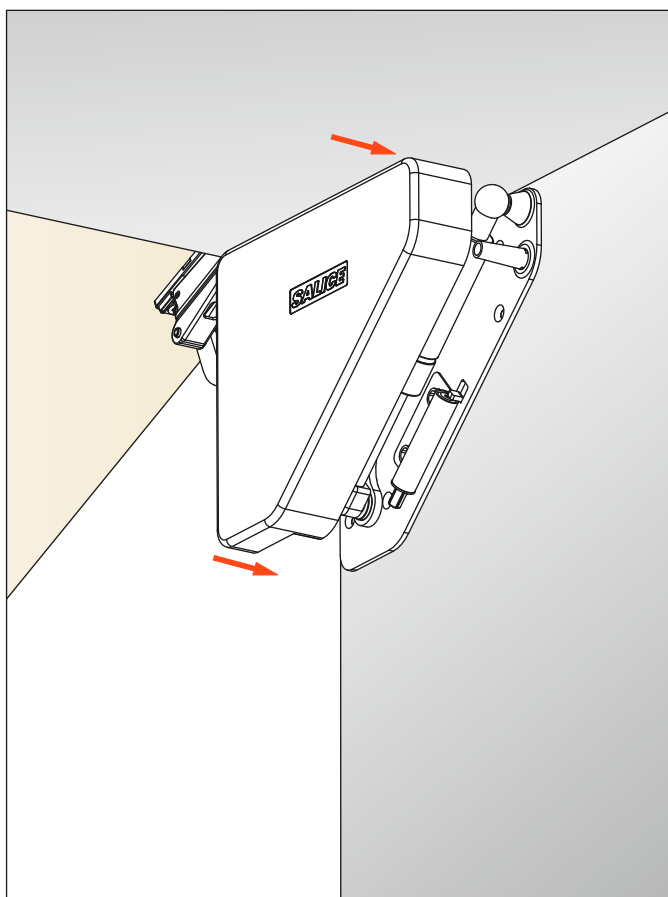



## Adjustments and additional fixing

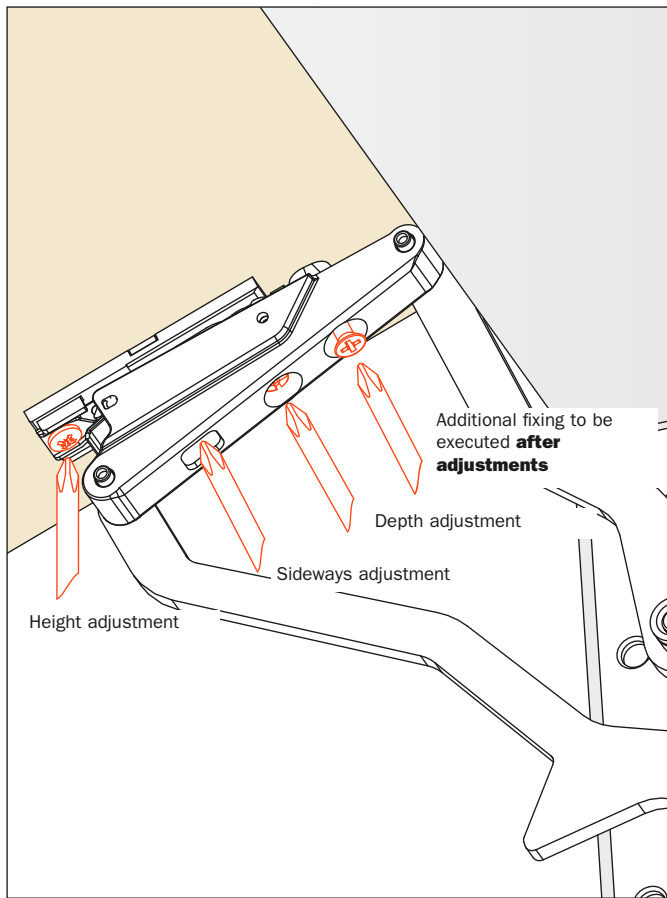

## Disassembly

- 1) Loosen the additional wood screw
- 2) then press firmly on the mounting plate lever
- 3) push the door

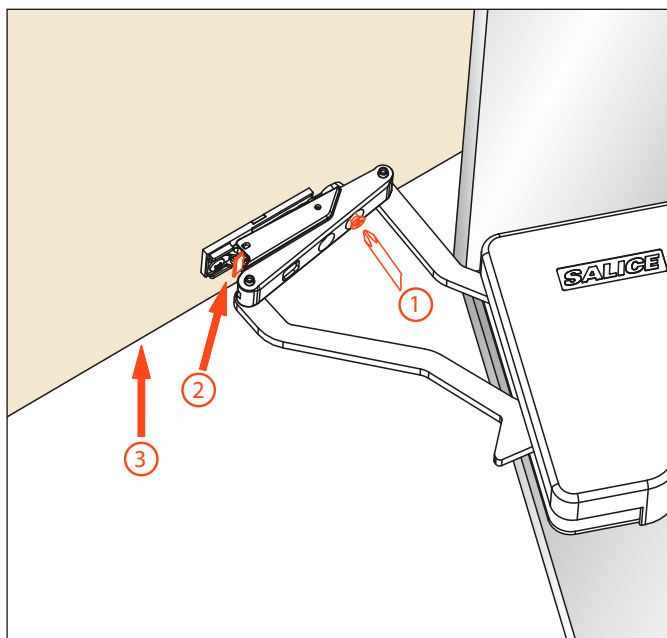

## Dimensions of the system

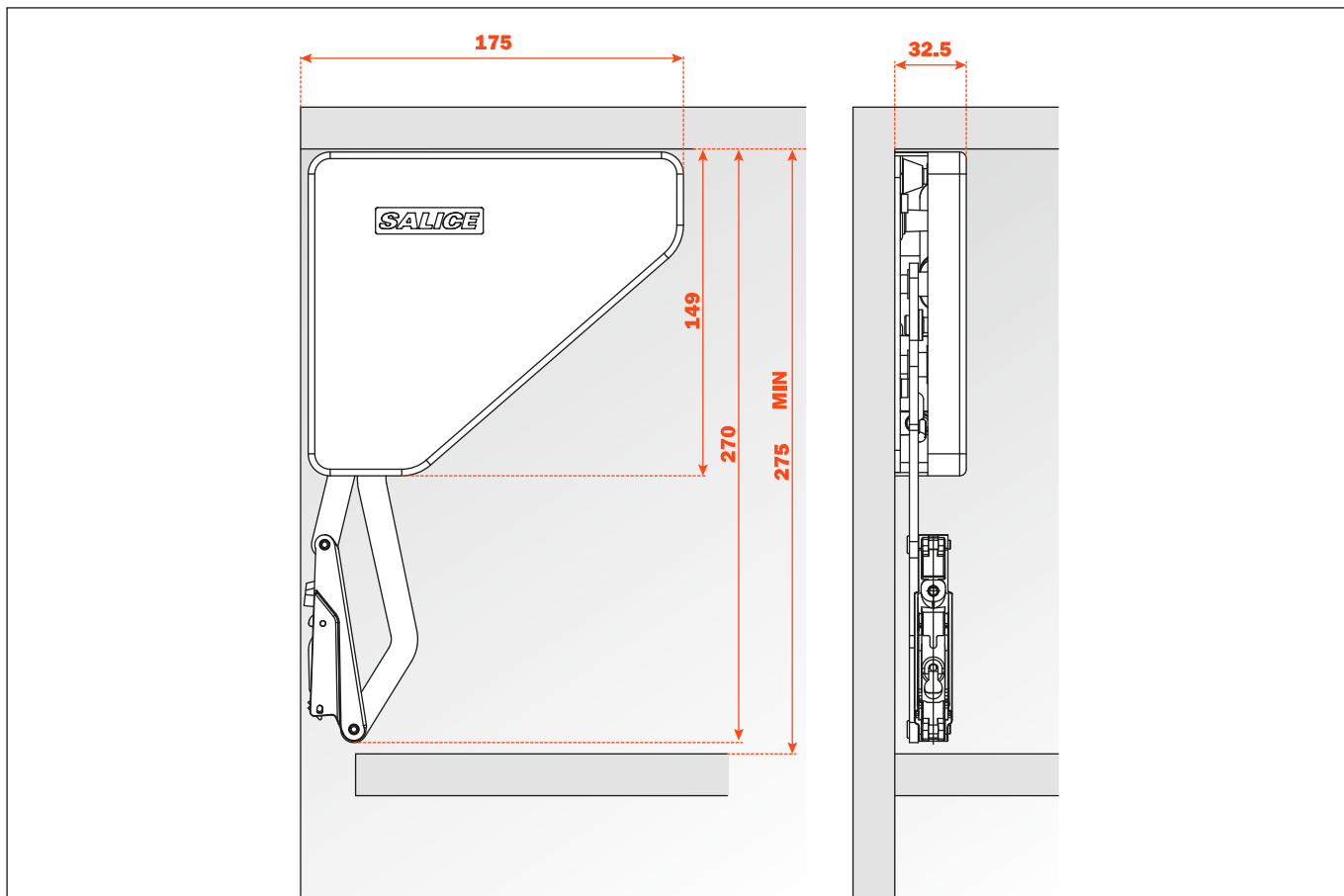

## Assembly scheme for cabinets over 1200 mm width



## Dimensions of the open door

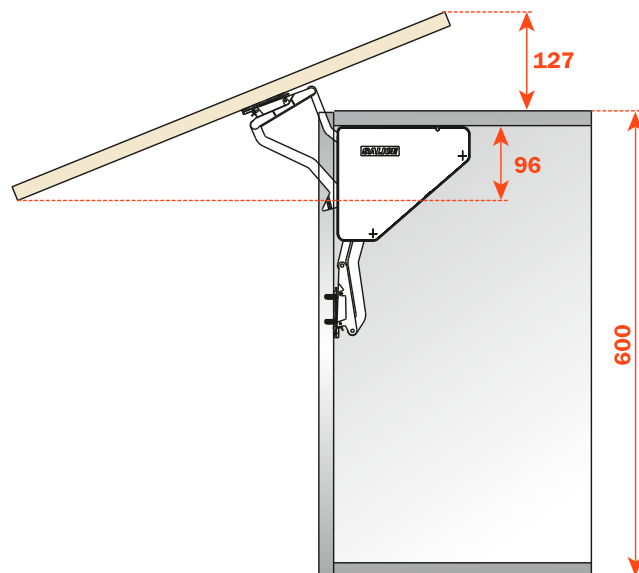
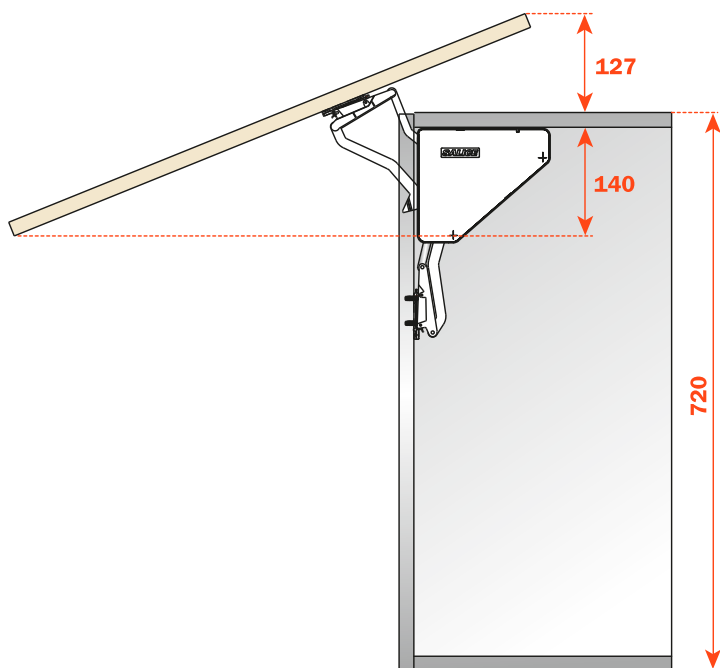
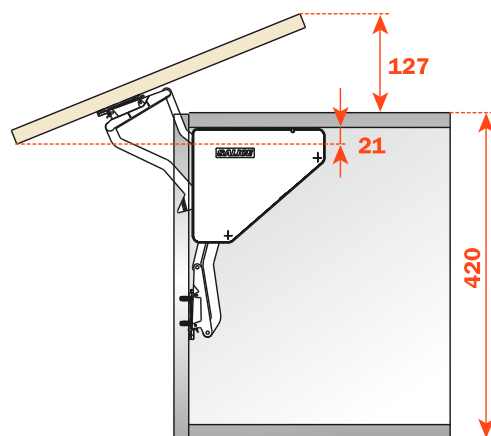
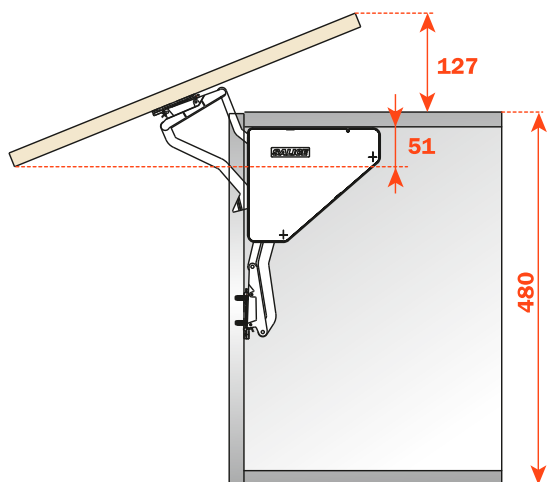

### Chart for FLMGSExxx pistons with single-operation door openin

Chart to define the exact strength of the pistons to be used in relationship with the dimensions and weight of the doors.

Cabinet width (mm)

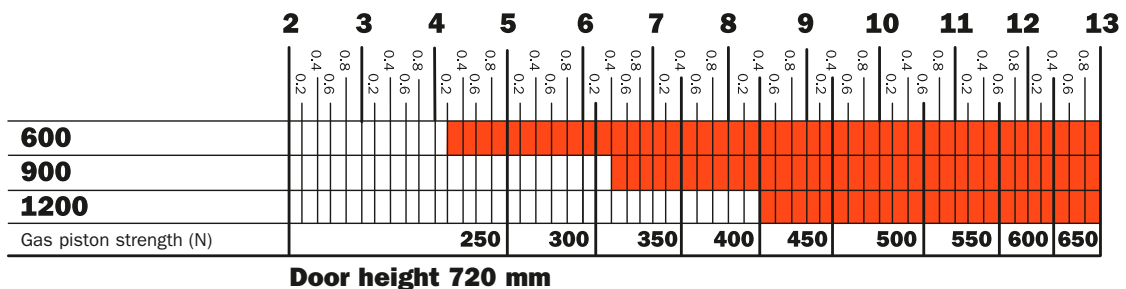
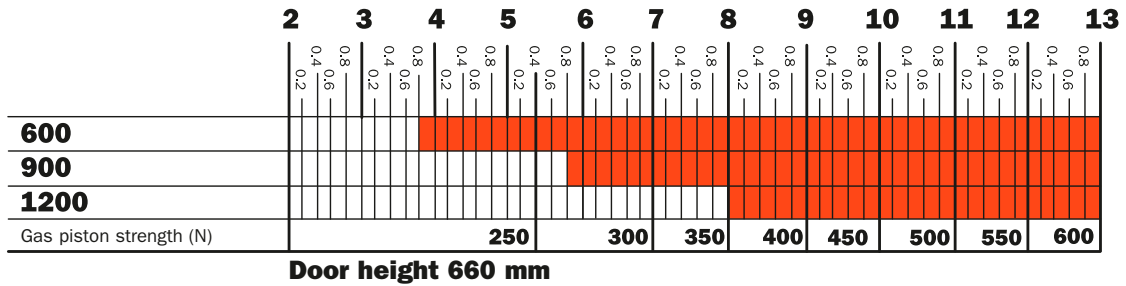
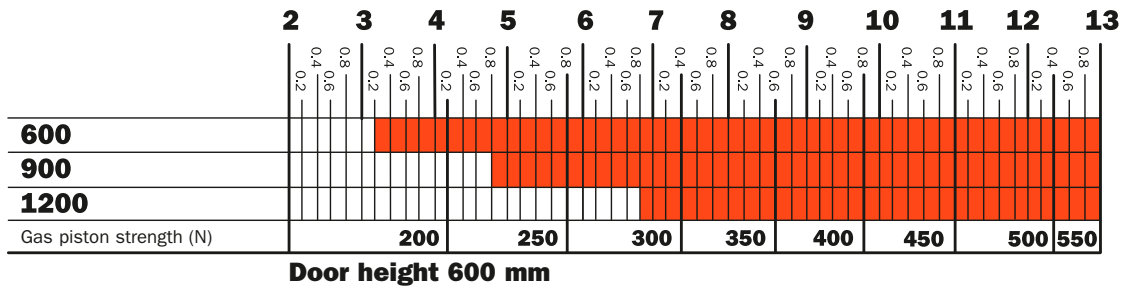
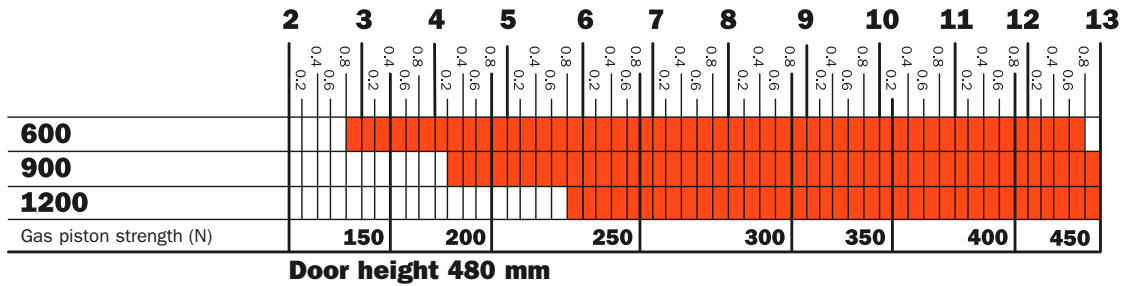
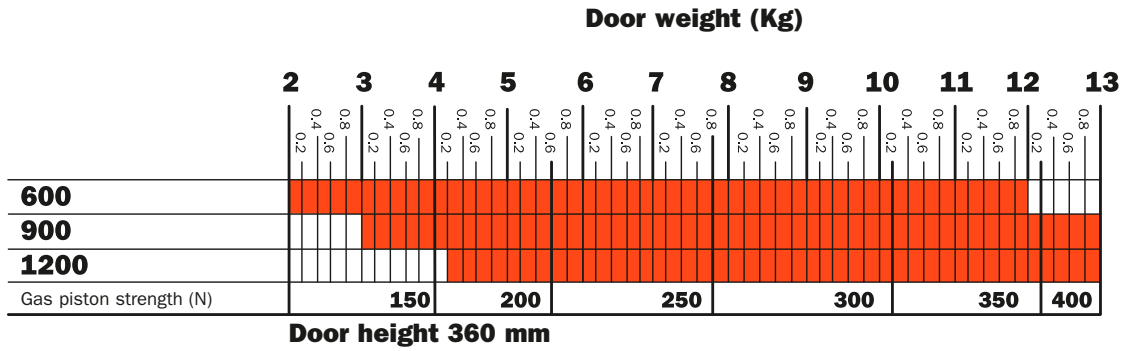

## Chart for FLMGRExxx pistons with progressive-operation door opening

Chart to define the exact strength of the pistons to be used in relationship with the dimensions and weight of the doors.

Cabinet width 600, 900 and 1200 mm

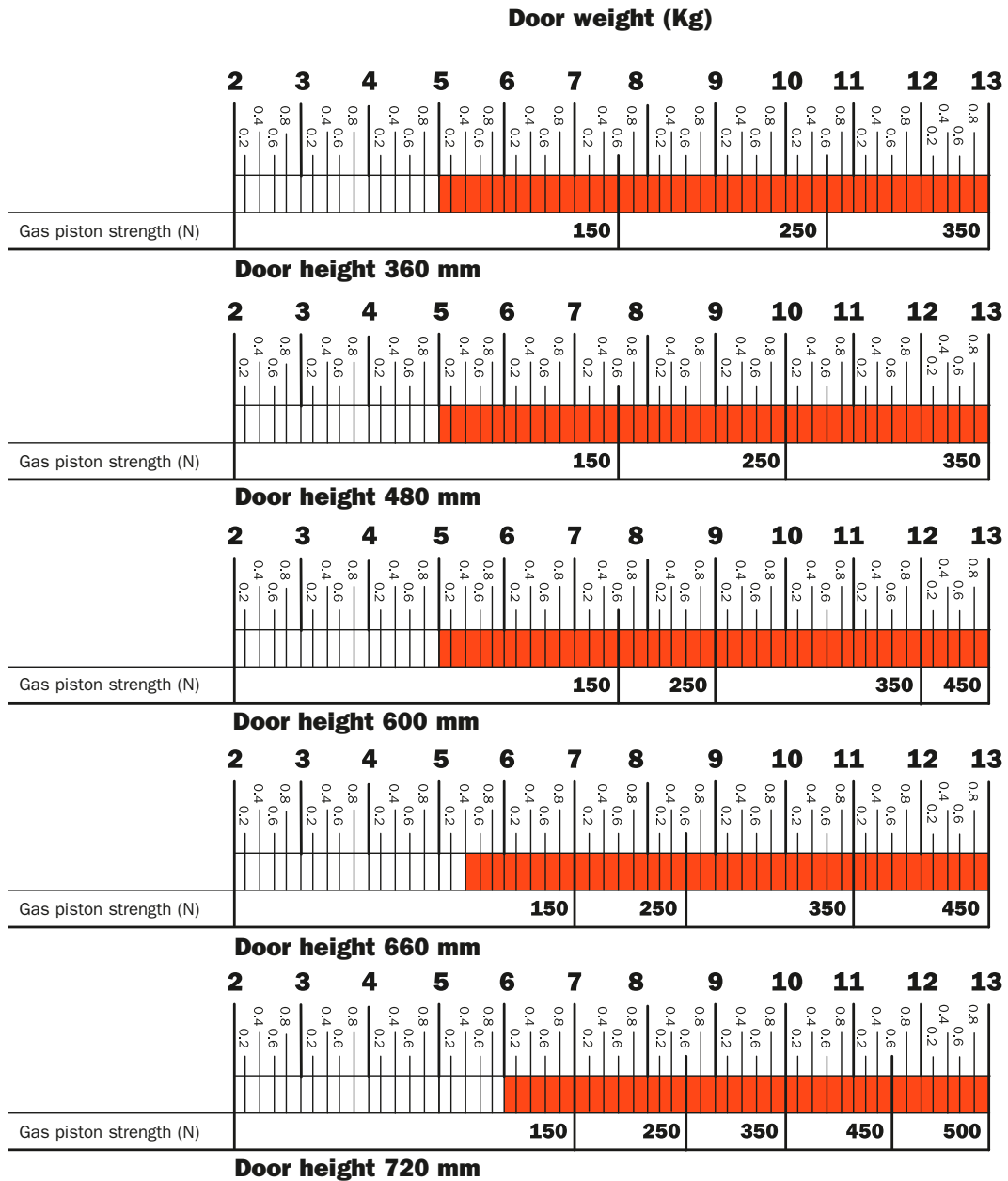

## Connecting fitting





# Connecting fitting

Simple nylon connecting fitting, knock-in.

- G98XA15** white
- G98XAG5** grey
- G98XA3V** black
- G98XAUV** brown colour.

### Packing

Boxes 1.200 pcs.  
Pallets 28.800 pcs.



### Drilling pattern

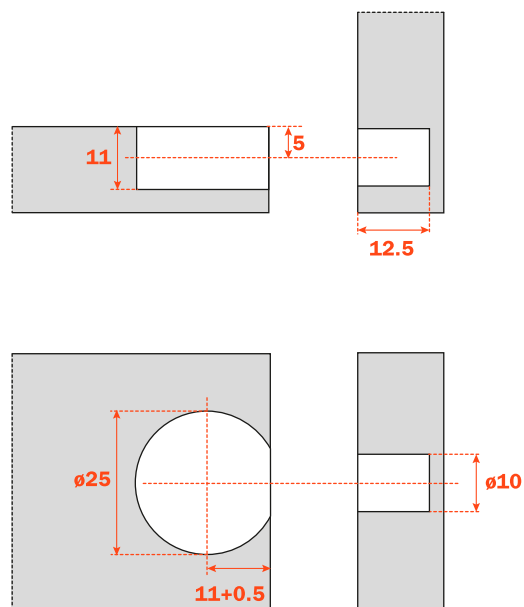

All versions of the connecting fittings are available in the following standard colours

### D98XAX3PE

Insertion tool for connecting fittings **G98X** and **G98Y**.



## Assembly

1  
Insert the connecting fitting in one of the two panels to be connected. Introduce the threaded part of the connecting fitting into the hole on the second panel, taking care that the lever is in the raised, open position.

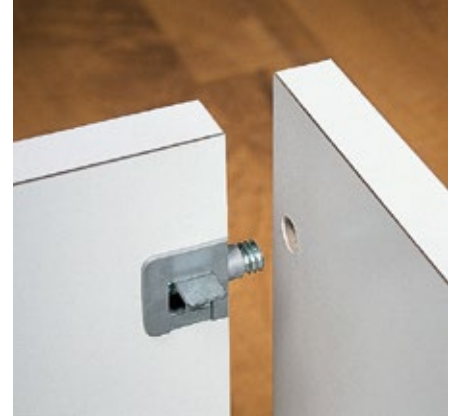
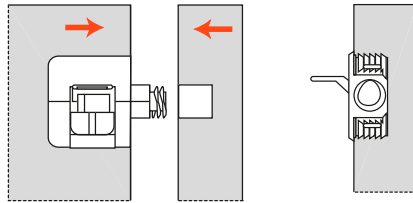

2  
Bring the two panels together and turn the lever all the way down.

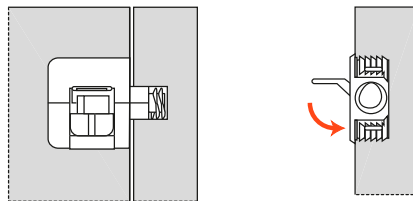

3  
While rotating, the threaded part pulls the two panels together, joining them in a secure way. The metal thread is driven firmly into the inner walls of the 10 mm hole.

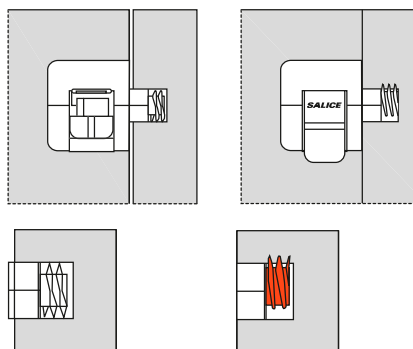

## Disassembly.

1  
Return the lever to the open position. Separate the two elements. Nothing remains inserted in the 10 mm hole.

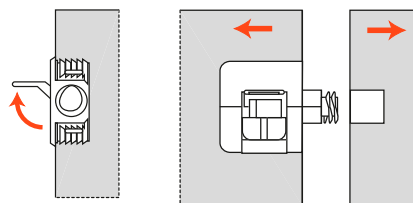



## Accessories



## Screw cover caps.

### S2BX83H9



Symmetrical steel screw cover cap, it can be personalised on request.

For all Series Silentia, 100, 200, 700, Logica, F, B, and 400 hinges.

### S2MX83H9



Symmetrical steel screw cover cap with embossed logo.

For all Series Silentia 100, 200, 700, Logica, F, B, and 400 hinges.

### S8XX83H9



Symmetrical steel screw cover cap, it can be personalised on request.

For Series Silentia 800 and 800 hinges.

### S8CX83H9



Symmetrical steel screw cover cap with embossed logo.

For Series Silentia 800 and 800 hinges.

### S2XX83A1



Symmetrical plastic screw cover cap, it can be personalised on request.

For all Series 100, 200, Logica, F and 400 hinges.

### S6XX83C1



**S6XX83C1**  
Plastic screw cover cap with symmetrical printed logo.  
For all Series 600 hinges.

**S6SX83C1 - S6DX83C1**  
Plastic screw cover cap with asymmetrical printed logo.  
For all Series 600 hinges.

### S9XX83H9



Steel symmetrical screw cover cap, it can be personalised on request.

For Series 900, Silentia Series 900, F hinges and complementary hinges Series 200 and 700.

### S9CX83H9



Symmetrical steel screw cover cap with embossed logo.

For Series 900, Silentia Series 900, F hinges and complementary hinges Series 200 and 700.

### S9XX83C1



Symmetrical plastic screw cover cap, it can be personalised on request.

For Series 900, Silentia Series 900, F hinges and complementary hinges Series 200 and 700.



## Flange cover caps

### S2XX85H9



Steel flange cover cap, it can be personalised on request.

For all Series Silentia, 100, 200, 300, 700, 800 and 900.

### S2CX85H9



Steel flange cover cap with embossed logo.

For all Series Silentia, 100, 200, 300, 700, 800 and 900.

## Spacers, gauge and fancy cover for Silentia hinges

# Silentia

### S2XF86



Spacer to reduce the drilling depth for 155° hinges.

**S2XF86BT** = 0.6 mm  
**S2XF86AT** = 1.2 mm  
**S2XF86KT** = 1.8 mm

### S2XX86



Spacer to reduce the drilling depth for 94°, 105° and 110° hinges.

**S2XX86BT** = 0.6 mm  
**S2XX86AT** = 1.2 mm  
**S2XX86KT** = 1.8 mm

### D\_A\_AC\_SN



Gauge to check the diameter and the depth of the drilling.

**D1A6AC3SN** = 12 mm  
**D2ABACGSN** = 15.5 mm  
**D7A6ACYSN** = 13.5 mm

### D1Z6HSK



Fancy cover for metal profiles hinges.



## Fancy covers for glass door hinge cup

**P2CTAX3**

Plastic, black



**P2CBAX3**

Plastic, black



**P2CTA13**

Plastic, lacquered black



**P2CBA13**

Plastic, lacquered black



**P2CTAX1**

Plastic, white



**P2CBAX1**

Plastic, white



**P2CTA08**

Plastic, bright gold effect



**P2CBA08**

Plastic, bright gold effect



**P2CTA0W**

Plastic, gold effect



**P2CBA0W**

Plastic, gold effect



**P2CTA06**

Plastic, bright chrome



**P2CBA06**

Plastic, bright chrome



---

**P2CTA09**

Plastic, silver effect

**P2CBA09**

Plastic, silver effect



---

**Spacers for Series 200, F and 600 hinges****S6A786XG**

Spacer for hinges with 26 mm diameter.



To be used to reduce the cup drilling depth by 1.5 mm.

**S2A786XG**

Spacer for hinges with 35 mm diameter.



To be used to reduce the cup drilling depth by 1.4 mm.

**SFA586XG**

Spacer for hinges with 40 mm diameter.



To be used to reduce the cup drilling depth by 1.5 mm.

## Stop devices

### S2AF37X3



Stop device

For 165° hinges,  
it limits opening at 120°.  
For 155° hinges,  
it limits opening at 125°.



### SBA237XG

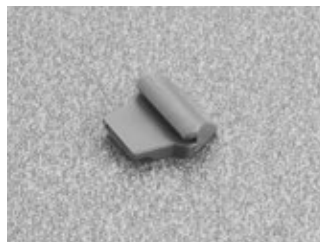

Stop device

For Series B hinges it limits  
opening at 90°.



### S2BF37XY



Stop device

For 165° hinges,  
it limits opening at 110°.  
For 155° hinges,  
it limits opening at 115°.



### S2A637XF



Stop device

For all hinges with 94° opening  
and 35 mm cup diameter, it limits  
opening at 86°.



### S2BH37XG

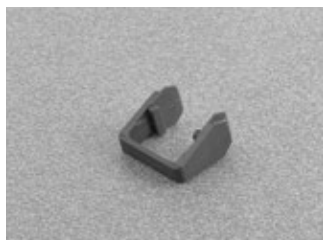

Stop device.

For hinge C2\_HA99, it limits  
opening at 110°.















## **ARTURO SALICE S.p.A.**

VIA PROVINCIALE NOVEDRATESE, 10  
22060 NOVEDRATE (COMO) ITALIA  
TEL. 031 790424  
FAX 031 791508  
info.salice@salice.com  
www.salice.com

### **DEUTSCHE SALICE GMBH**

RUDOLF DIESEL STR. 10  
POSTFACH 1154  
74382 NECKARWESTHEIM  
TEL. 07133 9807-0  
FAX. 07133 9807-16  
info.salice@deutschesalice.de  
www.deutschesalice.de

### **SALICE UK LTD.**

KINGFISHER WAY  
HINCHINGBROOKE BUSINESS PARK  
HUNTINGDON CAMBS PE 29 6FN  
TEL. 01480 413831  
FAX. 01480 451489  
info.salice@saliceuk.co.uk  
www.saliceuk.co.uk

### **DEUTSCHE SALICE GMBH**

VERKAUFSBÜRO NORD  
RINGSTRASSE 36/A30 CENTER  
32584 LÖHNE  
TEL. 05731 15608-0  
FAX. 05731 15608-10  
vknord@deutschesalice.de  
www.deutschesalice.de

### **SALICE AMERICA INC.**

2123 CROWN CENTRE DRIVE  
CHARLOTTE NC. 28227  
TEL. 704 8417810  
FAX. 704 8417808  
info.salice@saliceamerica.com  
www.saliceamerica.com

### **SALICE FRANCE S.A.R.L.**

ROUTE DE GOA ZAC LES 3 MOULINS  
06600 ANTIBES  
TEL. 0493 330069  
FAX. 0493 330141  
info.salice@salicefrance.com  
www.salicefrance.com

### **SALICE CANADA INC.**

4025 SLADEVIEW CRESCENT  
UNIT # 7-9  
MISSISSAUGA, ONTARIO L5L 5Y1  
TEL. 905 8208787  
FAX. 905 8207226  
info.salice@salicecanada.com  
www.salicecanada.com

### **SALICE ESPAÑA, S.L.U.**

CALLE COPÉRNICO, 11  
POLÍGONO INDUSTRIAL  
COLL DE LA MANYA  
08403 GRANOLLERS (BARCELONA)  
TEL. 938 46 88 61  
FAX 938 49 11 97  
info.salice@saliceespana.es  
www.saliceespana.es

**We reserve the right to change technical specifications without notice.**



