



Lapis
SALICE

Index



Lapis for thicker doors - 94° opening page 4

Lapis - 110° opening page 6

Lapis with Push system - 94° opening page 8



Plates page 10

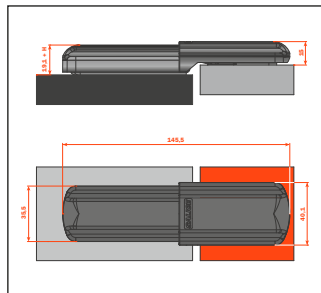

Hinge overall dimensions and sizes page 11



Assembly and disassembly instructions page 12



Finishes page 15



Technical information

Silentia hinges with cup integrated decelerating system and cover.

**Hinges for min. 18 mm thick doors.
15.5 mm deep cup.**

94° opening.
Possible drilling distance on the door (K): from 3 to 9 mm.

Adaptable only with longitudinal Domi snap-on mounting plates (BAP).

Space needed to open the door

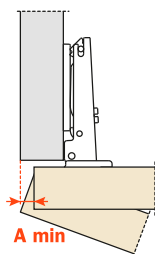

T=	19	20	21	22	23	24	25	26	27	28	29	30	31	32	33	34	35
K=3	A= 0.1	0.2	0.3	0.4	0.5	0.7	0.8	1.0	1.6	2.6	3.5	4.5	5.4	6.4	7.4	8.3	9.3
K=4	A= 0.1	0.2	0.3	0.4	0.5	0.7	0.8	1.0	1.2	1.9	2.8	3.8	4.7	5.7	6.6	7.6	8.6
K=5	A= 0.1	0.2	0.3	0.4	0.5	0.7	0.8	1.0	1.2	1.4	2.2	3.1	4.1	5.0	5.9	6.9	7.8
K=6	A= 0.1	0.2	0.3	0.4	0.5	0.6	0.8	1.0	1.2	1.4	1.7	2.6	3.5	4.4	5.3	6.2	7.2
K=7	A= 0.1	0.2	0.3	0.4	0.5	0.6	0.8	1.0	1.1	1.3	1.6	2.1	3.0	3.8	4.7	5.6	6.5
K=8	A= 0.1	0.2	0.3	0.4	0.5	0.6	0.8	0.9	1.1	1.3	1.6	1.8	2.5	3.3	4.2	5.1	6.0
K=9	A= 0.1	0.2	0.3	0.4	0.5	0.6	0.8	0.9	1.1	1.3	1.5	1.8	2.1	2.9	3.7	4.6	5.4

K	3	4	5	6	7	8	9
L=	0.0	0.0	0.0	0.0	0.0	0.3	1.3

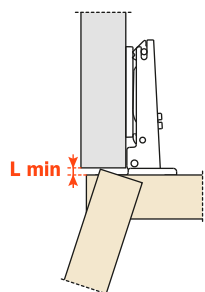

The above values are calculated on the assumption that the doors have square edges. They are reduced if the doors have radiussed edges.

Projection of the door

Projection of the door from the cabinet side at the max. opening. The figures are based on a straight arm hinge, H=0 mm thickness of mounting plate and K value = 3 mm.

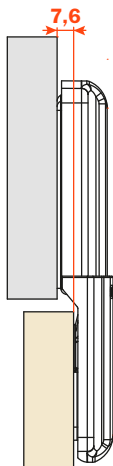

“C” value

With this formula you can obtain the max. thickness of the moulded door that can be opened without touching adjacent carcass sides, doors or walls, whilst bearing in mind the above L-K-T values.

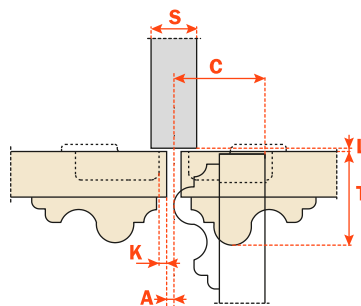

Packing

Boxes 300 pcs.
Pallets 7.200 pcs.

Use these formulas to determine the type of hinge arm, the drilling distance "K" and the height of the mounting plate "H" which is necessary to solve each application problem.

Arm 0

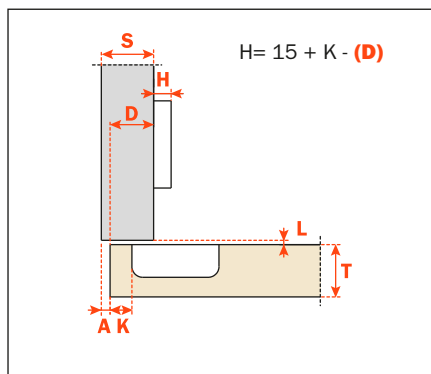

C21BAD9

Arm 9

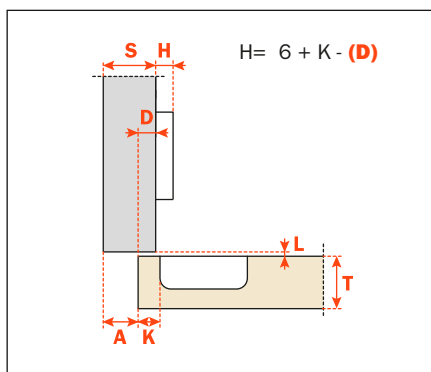

C21BGD9

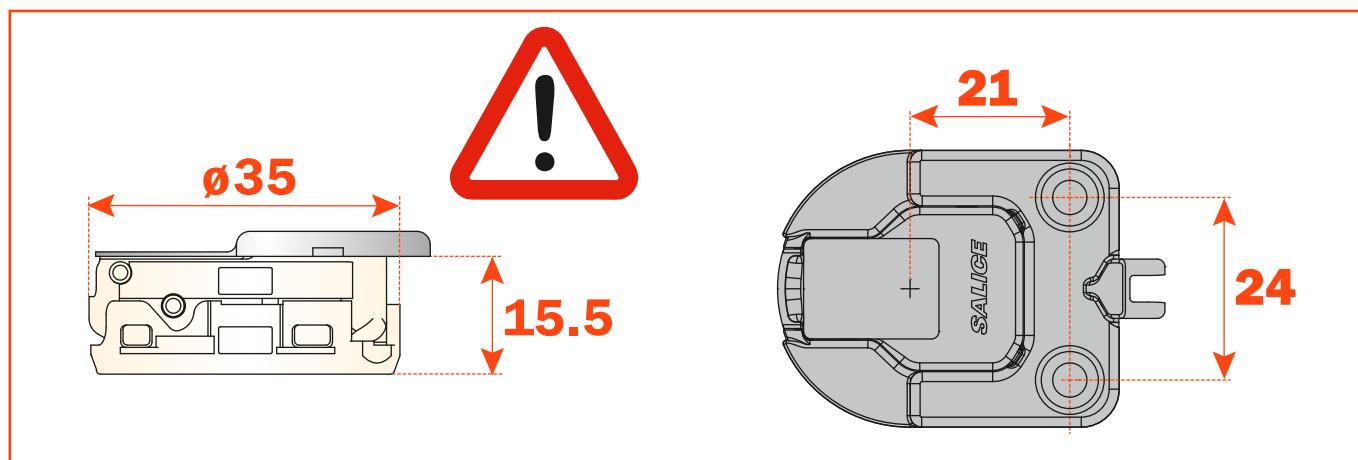



Technical information

Silentia hinges with cup integrated decelerating system and cover.

**Hinges for min. 16 mm thick doors.
13.5 mm deep cup.**

110° opening.
Possible drilling distance on the door (K): from 3 to 6 mm.

Adaptable only with longitudinal Domi snap-on mounting plates (BAP).

Space needed to open the door

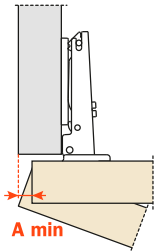

	T=	16	17	18	19	20	21	22	23	24	25	26
K=3	A=	0.7	0.9	1.1	1.3	1.6	1.9	2.2	2.6	3.2	4.4	5.7
K=4	A=	0.6	0.8	1.1	1.3	1.6	1.8	2.2	2.5	2.9	3.4	4.7
K=5	A=	0.6	0.8	1.0	1.3	1.5	1.8	2.1	2.4	2.8	3.2	3.7
K=6	A=	0.6	0.8	1.0	1.2	1.5	1.8	2.1	2.4	2.7	3.1	3.6

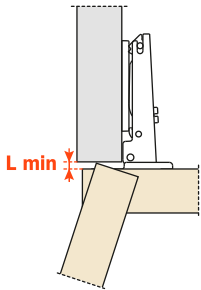

	T=	16	17	18	19	20	21	22	23	24	25	26
K=3	L=	0.0	0.0	0.0	0.0	0.0	0.0	0.0	0.2	0.4	0.6	0.9
K=4	L=	0.0	0.0	0.0	0.3	0.5	0.7	0.9	1.1	1.4	1.6	1.8
K=5	L=	0.6	0.8	1.0	1.2	1.5	1.7	1.9	2.1	2.4	2.6	2.8
K=6	L=	1.5	1.8	2.0	2.2	2.4	2.7	2.9	3.1	3.3	3.6	3.8

The above values are calculated on the assumption that the doors have square edges. They are reduced if the doors have radiussed edges.

Projection of the door

Projection of the door from the cabinet side at the max. opening. The figures are based on a straight arm hinge, H=0 mm thickness of mounting plate and K value = 3 mm.

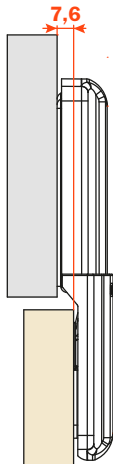

“C” value

With this formula you can obtain the max. thickness of the moulded door that can be opened without touching adjacent carcass sides, doors or walls, whilst bearing in mind the above L-K-T values.

$C = 22.5 + K + A$

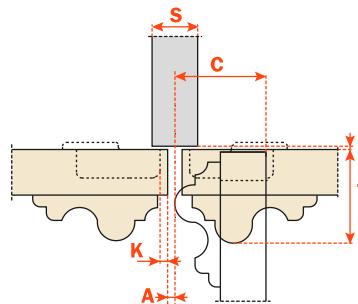

Packing

Boxes 300 pcs.
Pallets 7.200 pcs.

Use these formulas to determine the type of hinge arm, the drilling distance "K" and the height of the mounting plate "H" which is necessary to solve each application problem.

Arm 0

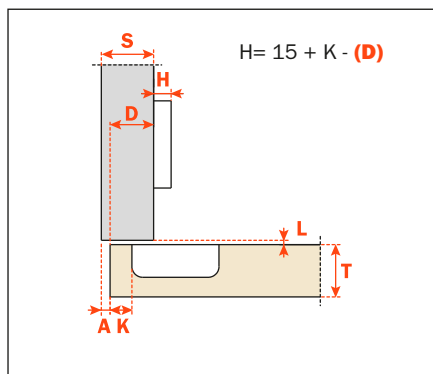

C716AD9

Arm 9

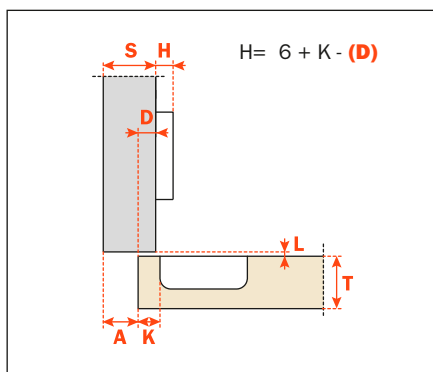

C716GD9

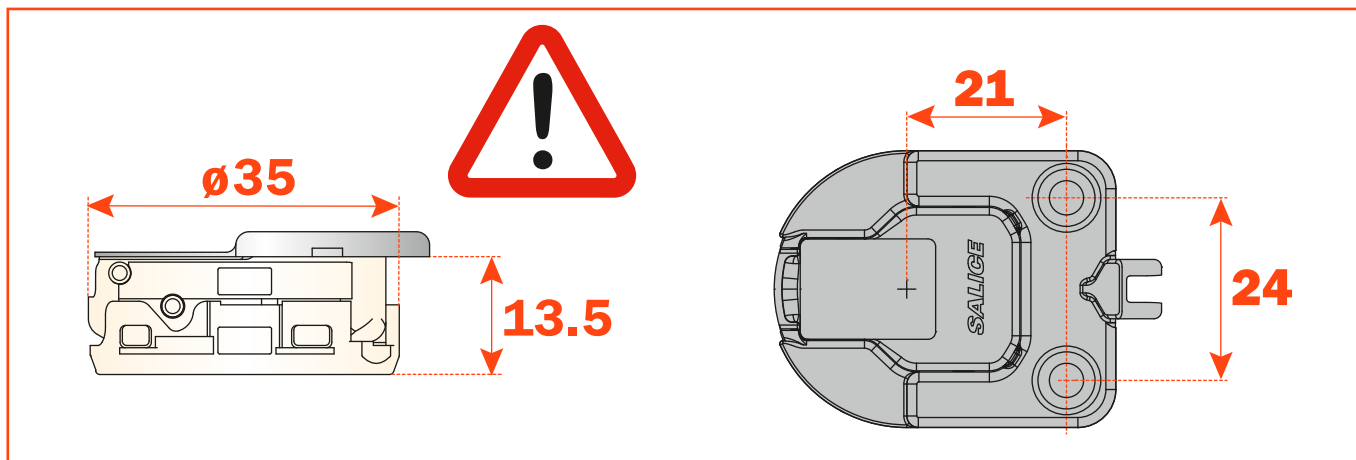

Lapis - Push - Series 200 hinges - For thicker doors - 94° opening



Technical information

Push hinges are equipped with a special spring that acts to open the door independently of the release device.

For thick doors up to 35 mm, with special profiles.
15.5 mm deep metal cup.
94° opening.

Possible drilling distance on the door (K): from 3 to 9 mm.

Adaptable only with longitudinal Domi snap-on mounting plates (BAP).

Space needed to open the door

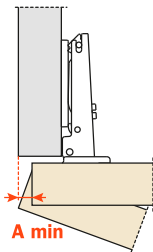

	T=	19	20	21	22	23	24	25	26	27	28	29	30	31	32	33	34	35
K=3	A=	0.1	0.2	0.3	0.4	0.5	0.7	0.8	1.0	1.6	2.6	3.5	4.5	5.4	6.4	7.4	8.3	9.3
K=4	A=	0.1	0.2	0.3	0.4	0.5	0.7	0.8	1.0	1.2	1.9	2.8	3.8	4.7	5.7	6.6	7.6	8.6
K=5	A=	0.1	0.2	0.3	0.4	0.5	0.7	0.8	1.0	1.2	1.4	2.2	3.1	4.1	5.0	5.9	6.9	7.8
K=6	A=	0.1	0.2	0.3	0.4	0.5	0.6	0.8	1.0	1.2	1.4	1.7	2.6	3.5	4.4	5.3	6.2	7.2
K=7	A=	0.1	0.2	0.3	0.4	0.5	0.6	0.8	1.0	1.1	1.3	1.6	2.1	3.0	3.8	4.7	5.6	6.5
K=8	A=	0.1	0.2	0.3	0.4	0.5	0.6	0.8	0.9	1.1	1.3	1.6	1.8	2.5	3.3	4.2	5.1	6.0
K=9	A=	0.1	0.2	0.3	0.4	0.5	0.6	0.8	0.9	1.1	1.3	1.5	1.8	2.1	2.9	3.7	4.6	5.4

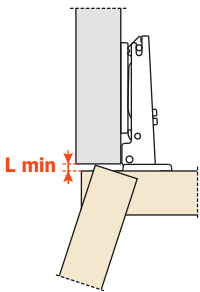

K=	3	4	5	6	7	8	9
L=	0.0	0.0	0.0	0.0	0.0	0.3	1.3

The above values are calculated on the assumption that the doors have square edges. They are reduced if the doors have radiussed edges.

Projection of the door

Projection of the door from the cabinet side at the max. opening. The figures are based on a straight arm hinge, H=0 mm thickness of mounting plate and K value = 3 mm.

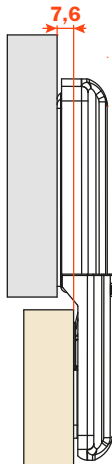

“C” value

With this formula you can obtain the max. thickness of the moulded door that can be opened without touching adjacent carcass sides, doors or walls, whilst bearing in mind the above L-K-T values.

$$C = 23 + K + A$$

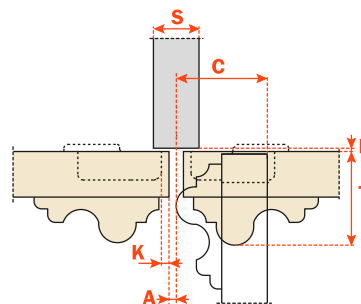

Packing

Boxes 300 pcs.
Pallets 7.200 pcs.

Use these formulas to determine the type of hinge arm, the drilling distance “K” and the height of the mounting plate “H” which is necessary to solve each application problem.

Arm 0

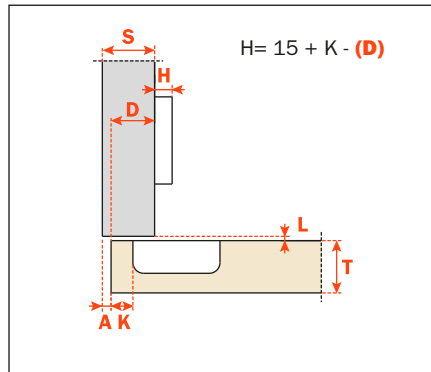

C21VA99

Arm 9

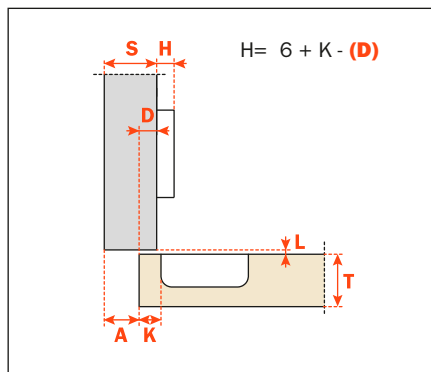

C21VG99

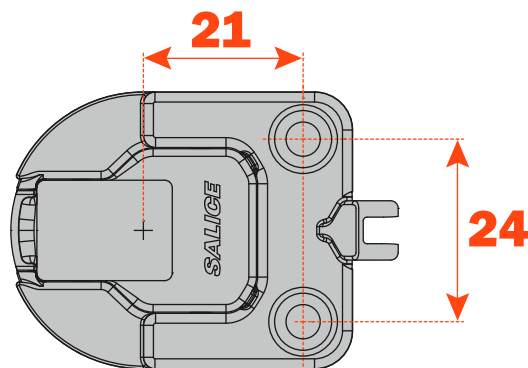

For the complete range of release devices and retaining catches consult Salice general catalogue.

Domi snap-on mounting plates

Packing

Boxes 300 pcs.
Pallets 7.200 pcs.

- 21+32 mm drilling.
- Depth and height adjustment by cam.

BAP3R



Die-cast mounting plates.
Fixing: wood screw.

B 3.5 DIN 7983.

H= 0 1 2 3 4 5 6

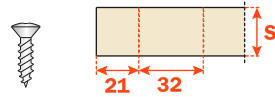

BAPGR



Die-cast mounting plates.
Fixing: Euro screw.
Drilling $\varnothing 5 \times 11$.

H= 0 1 2 3 4 5 6

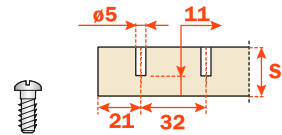

BAPMR



Die-cast mounting plates.
Fixing: expanding dowel.
Drilling $\varnothing 10 \times 11.5$ mm.

H= 0 1 2 3 4 5 6

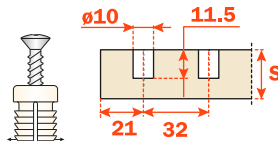

BAP7R

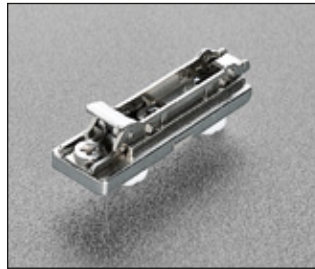

Die-cast mounting plates.
Fixing: knock-in dowel.
Drilling $\varnothing 10 \times 11.5$ mm.

H= 0 1 2 3 4 5 6

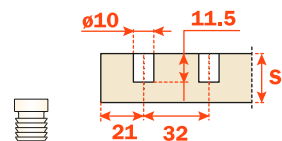

Use mounting plates with 6 mm maximum height

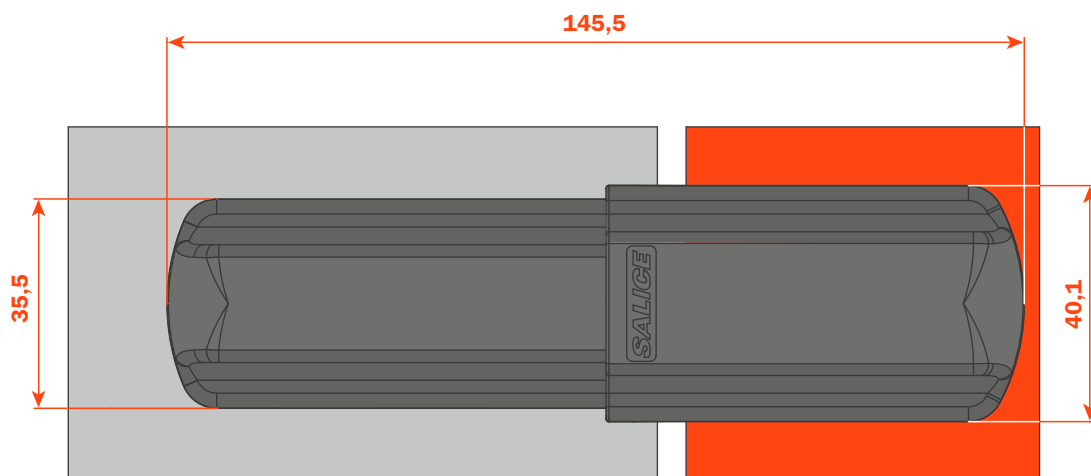

Lapis hinge - 0 arm - 0 mounting plate

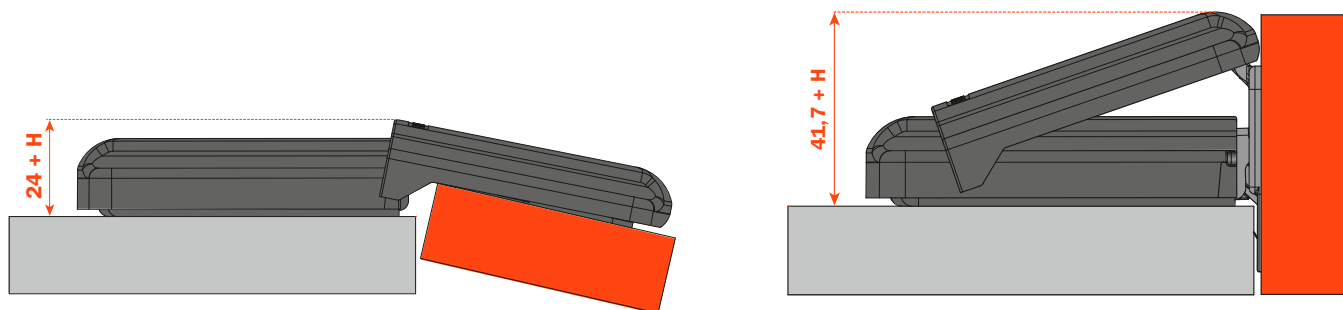

Lapis hinge - 9 arm - 0 mounting plate

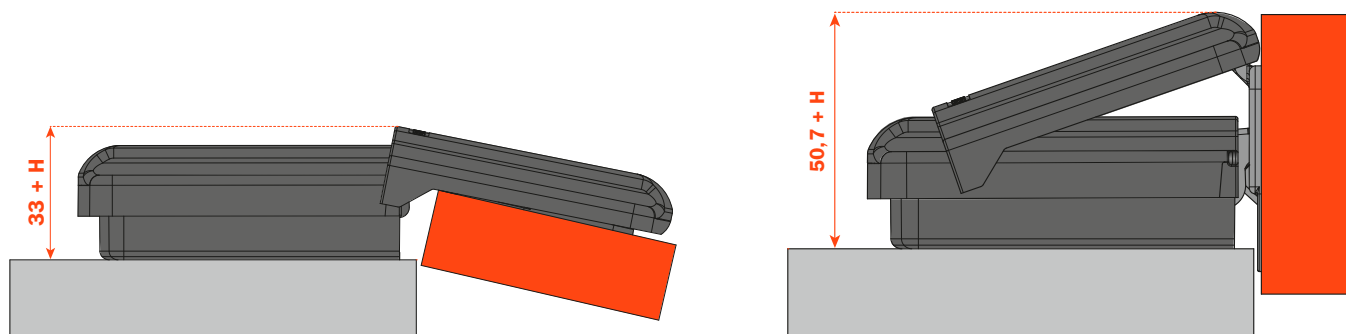

Assembly instructions

After fixing the mounting plate, attach the skirt.

Attached skirt.



Clip the hinge onto the mounting plate.

ATTACHMENT OF THE HINGE ARM COVER



Clip the cover onto the hinge arm.

Press to clip the cover.



ATTACHMENT OF THE DOOR SIDE COVER

Lift the carrier.

Clip the cover onto the carrier.



Half-close the door to ensure that the covers are engaged correctly.



Disassembly instructions

Half-close the door and lift the cover.



Open the door and push the cover firmly in the direction indicated.



Remove the cabinet side cover.



Unclip the hinge from the mounting plate.



Remove the skirt.



P7A0A09
SATIN CHROME

Lapis cabinet side - Arm 0

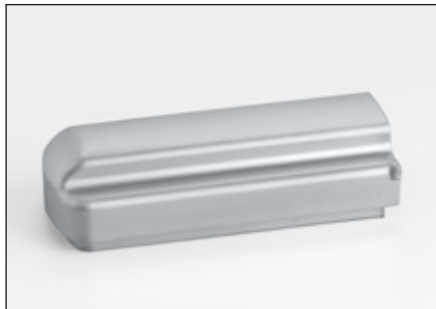

P7A9A09
SATIN CHROME

Lapis cabinet side - Arm 9

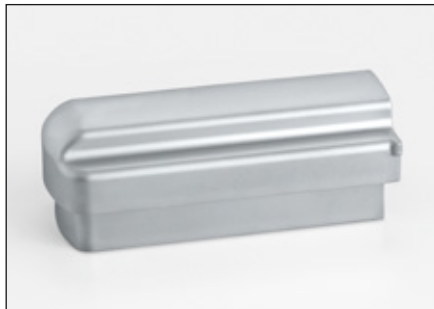

P7SXA09SN
SATIN CHROME

Lapis door side



P7A0A10
SATIN METAL BLACK

Lapis cabinet side - Arm 0

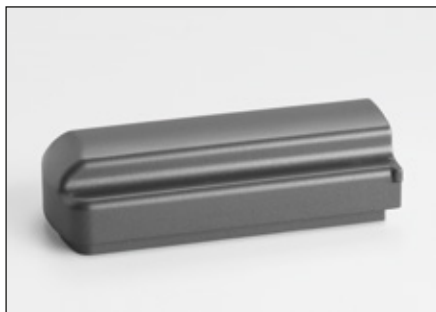

P7A9A10
SATIN METAL BLACK

Lapis cabinet side - Arm 9

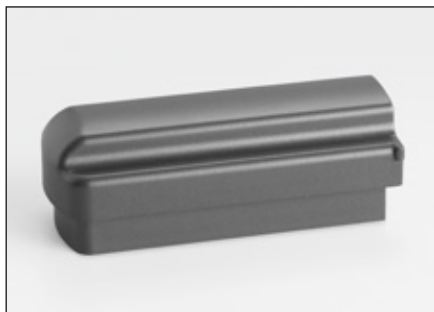

P7SXA10SN
SATIN METAL BLACK

Lapis door side

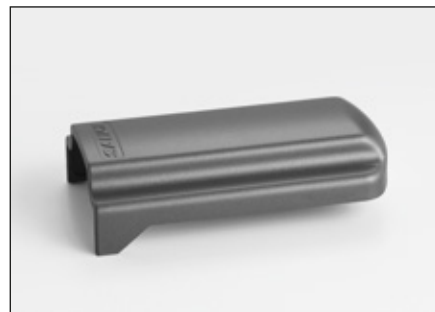

P7A0A1W
SATIN GOLD

Lapis cabinet side - Arm 0



P7A9A1W
SATIN GOLD

Lapis cabinet side - Arm 9



P7SXA1WSN
SATIN GOLD

Lapis door side



P7A0A0C
CHAMPAGNE

Lapis cabinet side - Arm 0



P7A9A0C
CHAMPAGNE

Lapis cabinet side - Arm 9



P7SXA0CSN
CHAMPAGNE

Lapis door side



P7A0A06
GLOSSY CHROME

Lapis cabinet side - Arm 0



P7A9A06
GLOSSY CHROME

Lapis cabinet side - Arm 9

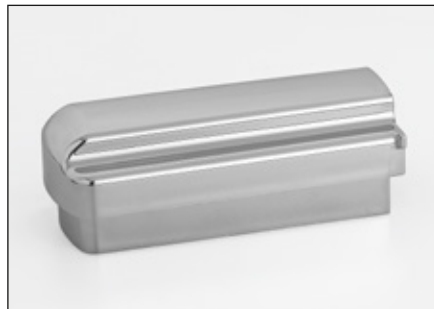

P7SXA06SN
GLOSSY CHROME

Lapis door side

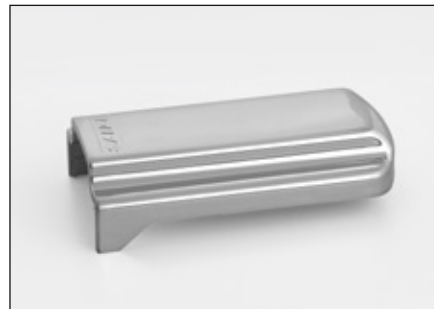

P7A0A0N
GLOSSY METAL BLACK

Lapis cabinet side - Arm 0



P7A9A0N
GLOSSY METAL BLACK

Lapis cabinet side - Arm 9



P7SXA0NSN
GLOSSY METAL BLACK

Lapis door side



P7A0A0I
STAINLESS STEEL

Lapis cabinet side - Arm 0



P7A9A0I
STAINLESS STEEL

Lapis cabinet side - Arm 9



P7SXA0ISN
STAINLESS STEEL

Lapis door side



P7A0A05
GRAPHITE

Lapis cabinet side - Arm 0



P7A9A05
GRAPHITE

Lapis cabinet side - Arm 9



P7SXA05SN
GRAPHITE

Lapis door side

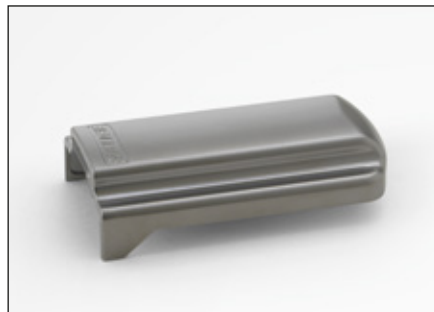

P7A0A08
GLOSSY GOLD

Lapis cabinet side - Arm 0



P7A9A08
GLOSSY GOLD

Lapis cabinet side - Arm 9

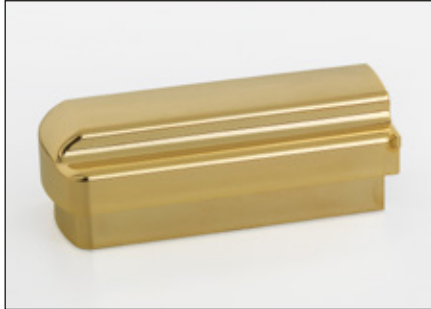

P7SXA08SN
GLOSSY GOLD

Lapis door side



P7A0A07
OLD BRASS

Lapis cabinet side - Arm 0



P7A9A07
OLD BRASS

Lapis cabinet side - Arm 9



P7SXA07SN
OLD BRASS

Lapis door side



P7A0AA3
BLACK

Lapis cabinet side - Arm 0

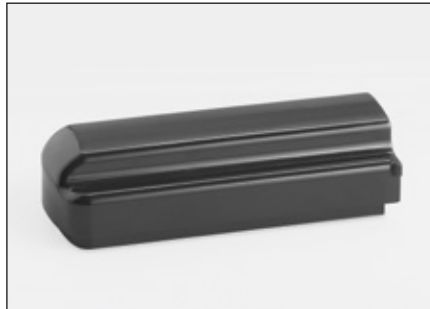

P7A9AA3
BLACK

Lapis cabinet side - Arm 9



P7SXAA3SN
BLACK

Lapis door side

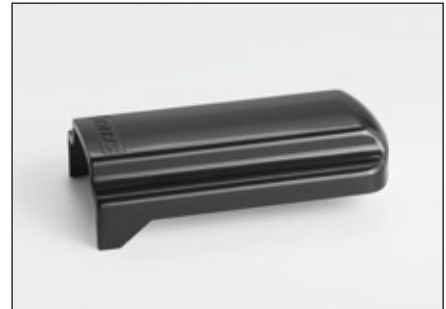

P7A0A11
MATT WHITE

Lapis cabinet side - Arm 0



P7A9A11
MATT WHITE

Lapis cabinet side - Arm 9

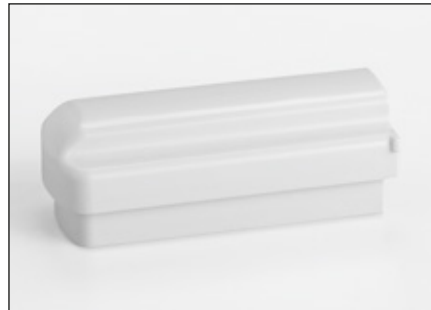

P7SXA11SN
MATT WHITE

Lapis door side



SALICE AMERICA Inc.

2123 CROWN CENTRE DRIVE
USA - CHARLOTTE, NC 28227
TEL. 1-800-222-9652/704-841-7810
FAX 704-841-7808
info.salice@saliceamerica.com
www.saliceamerica.com

Ed 04 - 06/2015

We reserve all rights to this catalogue under copyright law. It shall not be permissible to duplicate this catalogue in any form either in whole or in part without our written consent. The technical specifications in this catalogue as photographs and drawings are not binding. We assume no liability for any misprints or errors that might occur in this catalogue.

We reserve the right to change technical specifications without notice.
Lapis design: Arch. Giulio Manzoni