



WIND
SALICE

USA CDN

WIND



The Wind lift system is characterized by compactness and elegant design.

Its movement is smooth and perfectly controlled. Wind is small and unobtrusive, enabling the maximum utilization of cabinet internal space. Suitable for Kitchen cabinets, living room or bedroom furniture and office furniture.

In the kitchen environment, Wind has strong functional appeal - a compact adjustable lift system that takes up a minimum of valuable storage space.

Aesthetics also play a key role with Wind's small size and streamlined shape adding significantly to the overall appeal of the cabinets to which it is installed.

Wind is available in a range of attractive finishes designed to complement the vast range of cabinet applications that it can be used for.

Wind Lift system is a simple program that covers a large variety of door sizes.





Technical information

Flap door lift system fixed to the cabinet sides.

Drilling of the door $\varnothing 35$.
 13 mm deep cup.
 85° opening with stop device (premounted).
 94° opening without stop device.
 Minimum door height 220mm / 8-5/8"
 Maximum door height 610mm / 24"
 Possible drilling distance on the door (K): from 3 to 7 mm.

Drilling pattern - Dimensions Frameless

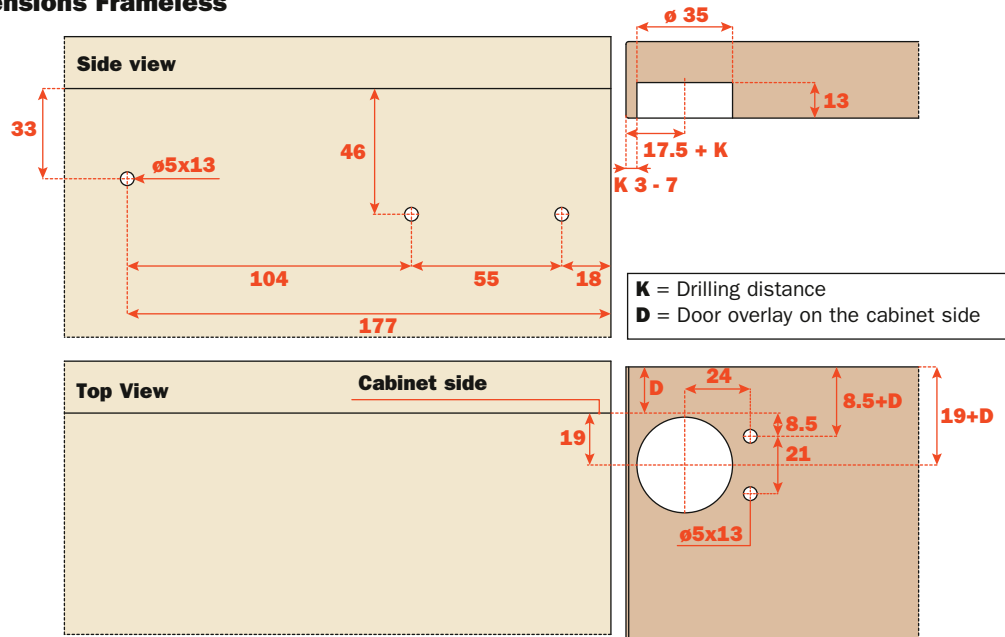

Space needed to open the door

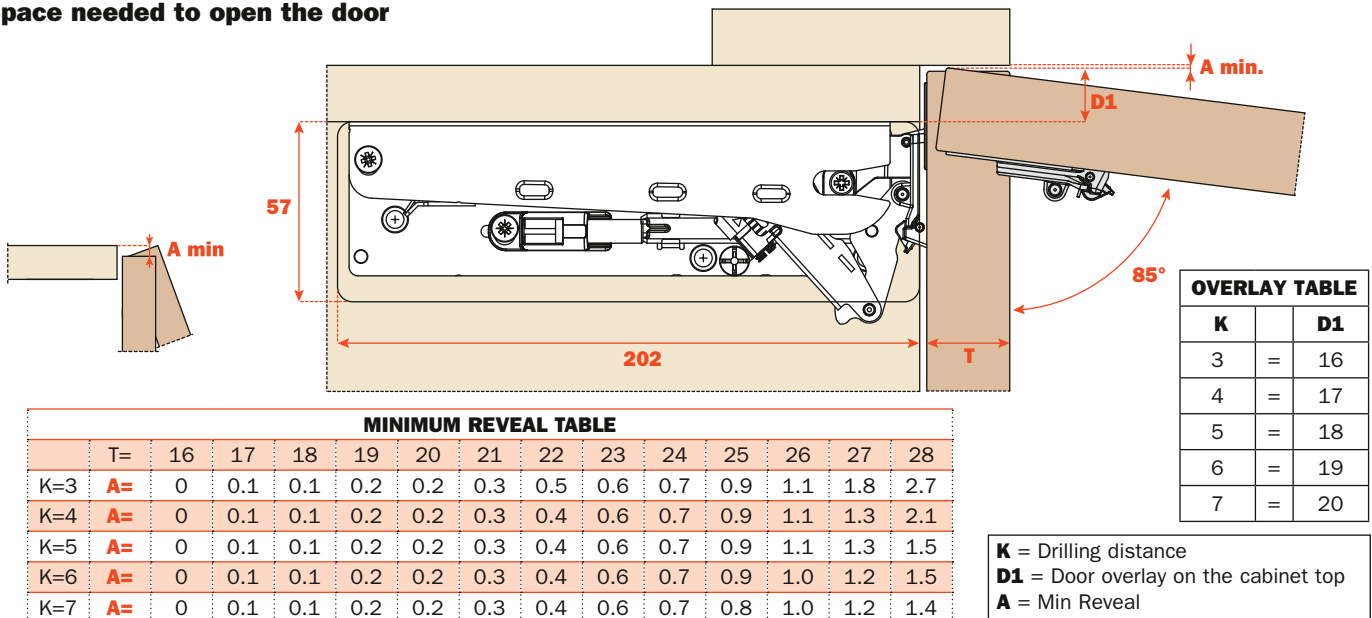

Drilling pattern - Dimensions - Frame

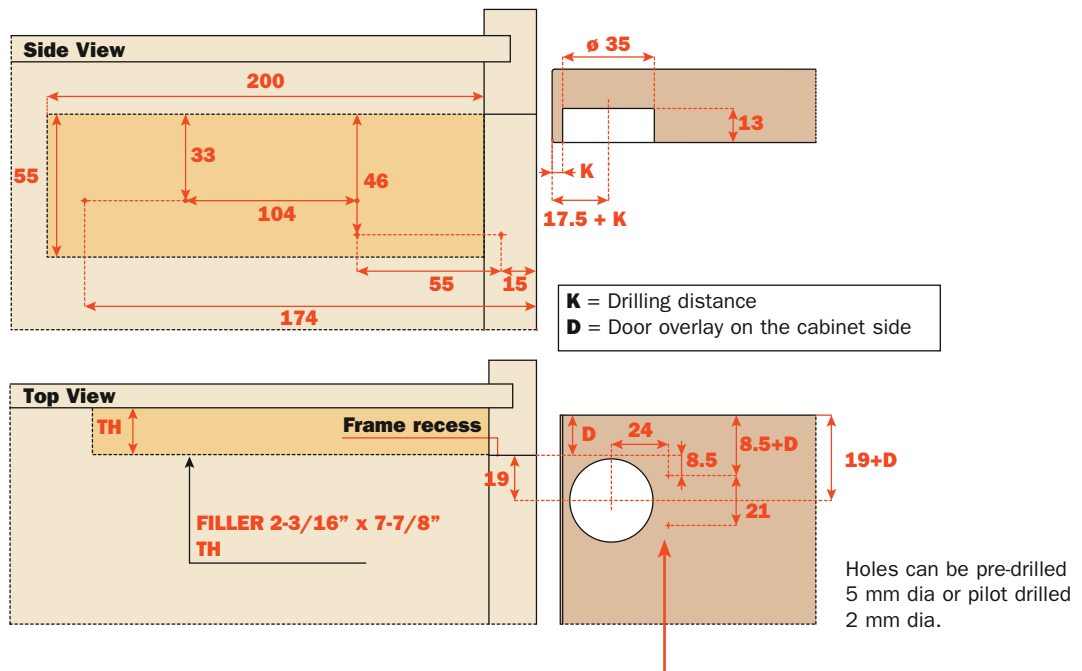

Space needed to open the door

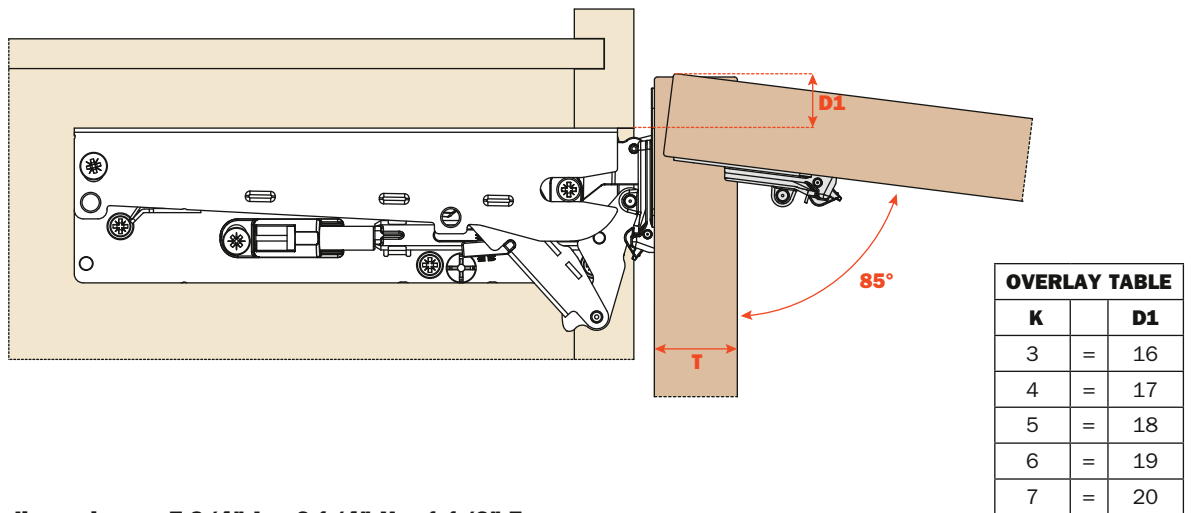

Wind "Footprint" dimensions= 7-3/4" L x 2-1/4" H x 1-1/2" T

K = Drilling distance
D1 = Door overlay on the cabinet top

Attaching the base to the cabinet sides

Use 5mm x 13mm system screws or #7 x 5/8" wood screws.

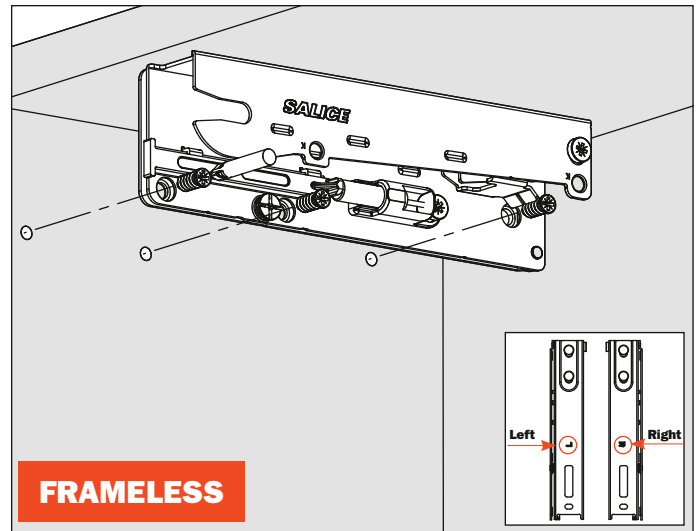
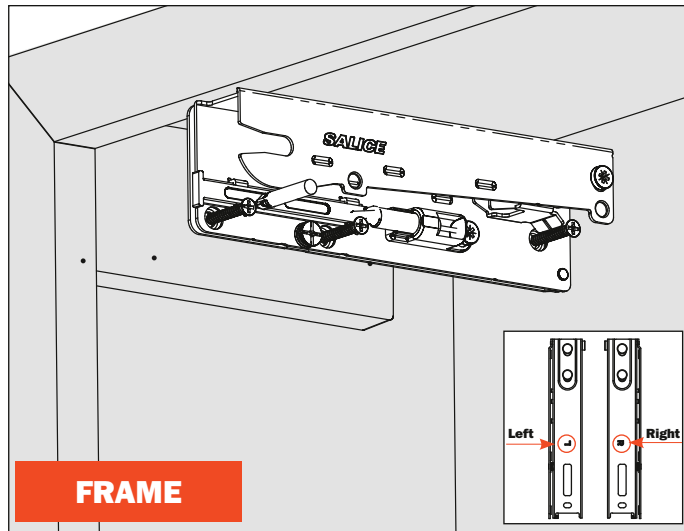

Installing the cups to the door

Use 5mm x 13mm system screws or #7 x 5/8" wood screws.

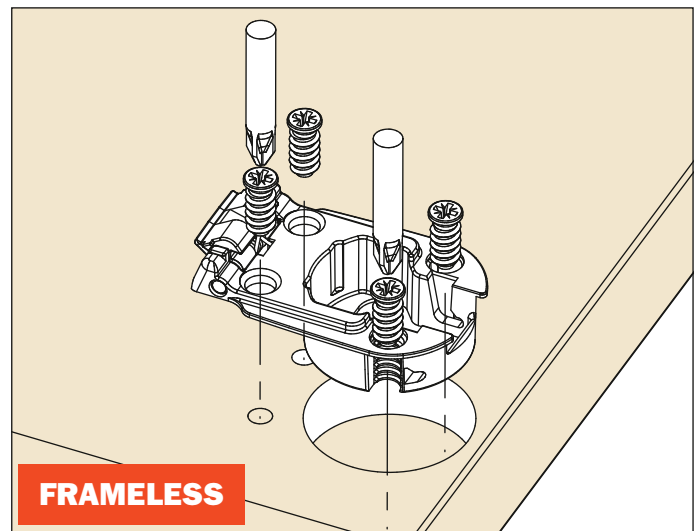
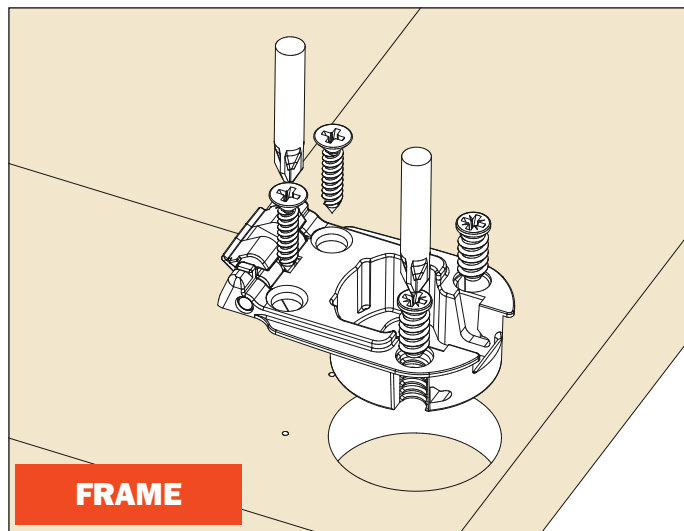

Connecting the lift mechanism to the cups

This operation is tool free.

Note:
LH lift mechanism must be installed in LH base,
RH lift mechanism must be installed in RH base.

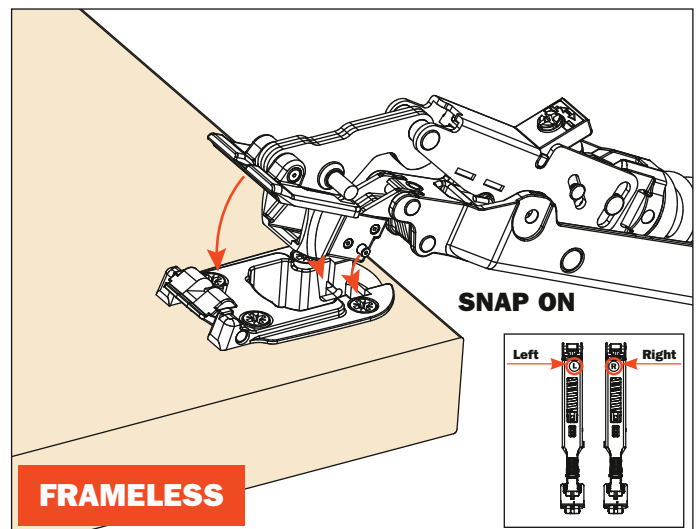
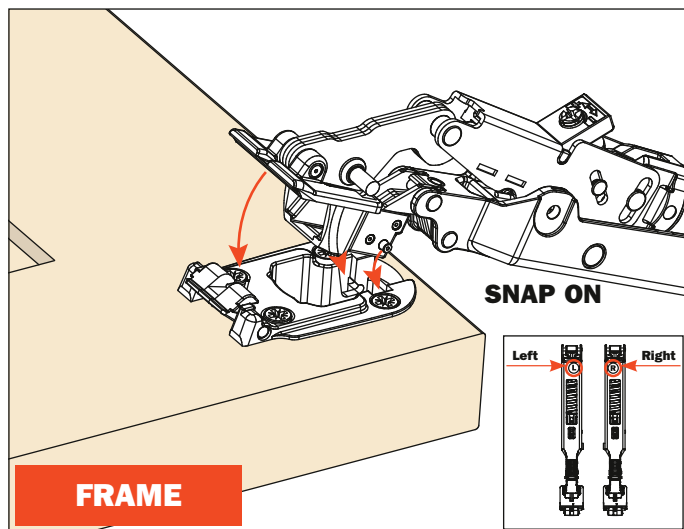

Connecting the lift system to the base

This operation is tool free.

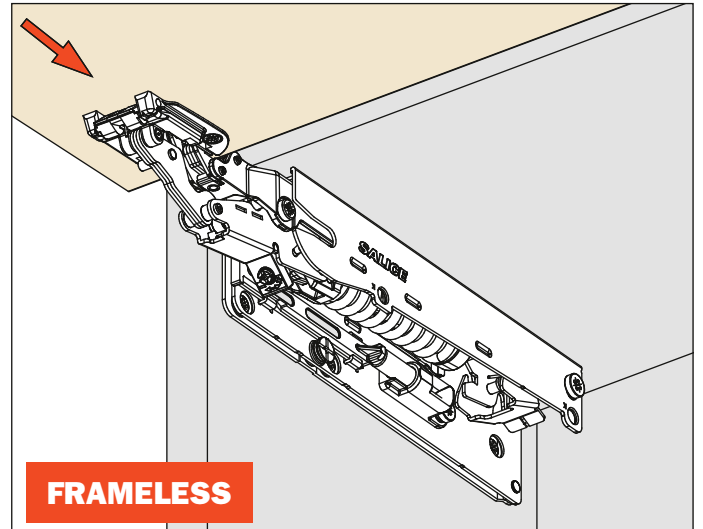
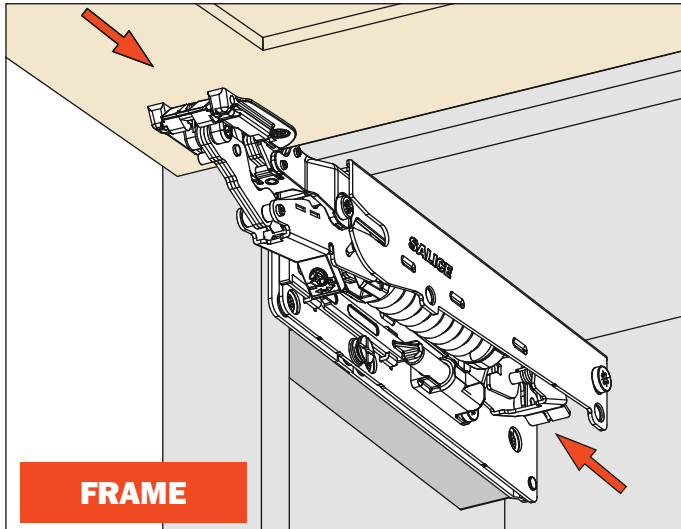

Installing the covers

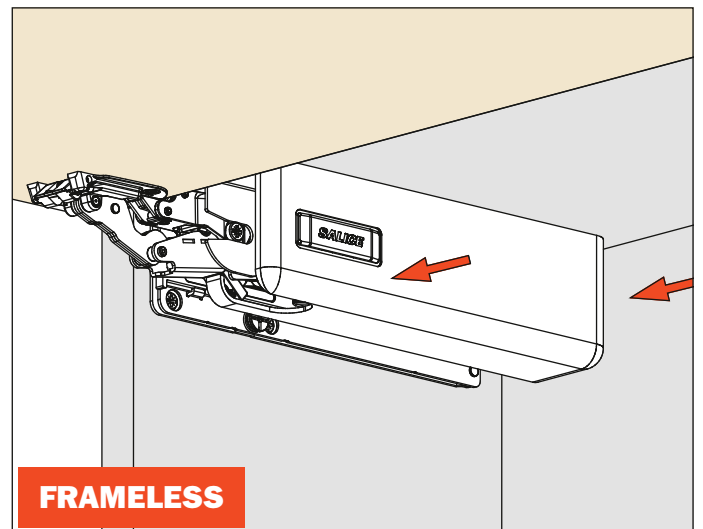
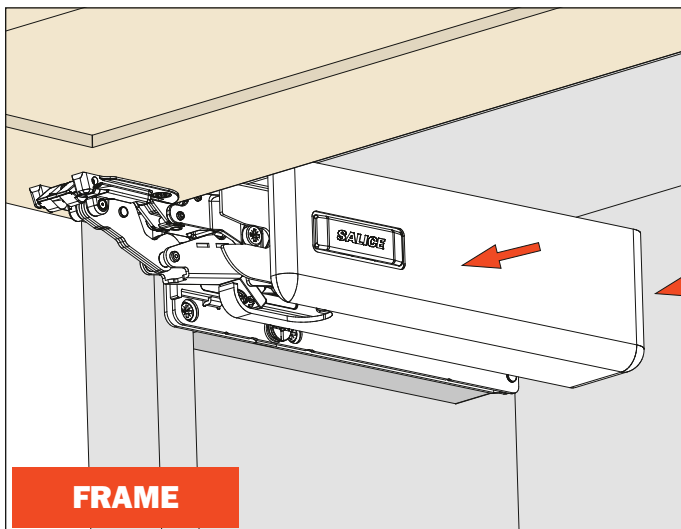



WARNING ! Security cable ties.

Remove the cable ties only at the end of the assembly.
Use the instructions and the QR Code attached to the systems.



Adjustments.

- 1 - adjustment of the spring strength.
- 2 - adjustment of the decelerating effect.
- 3 - removal of the angle reduction clip.
- 4 - height adjustment of the door from - 2 to +2.
- 5 - side adjustment of the door from - 2 to +2.
- 6 - depth adjustment of the door from - 1 to +3.

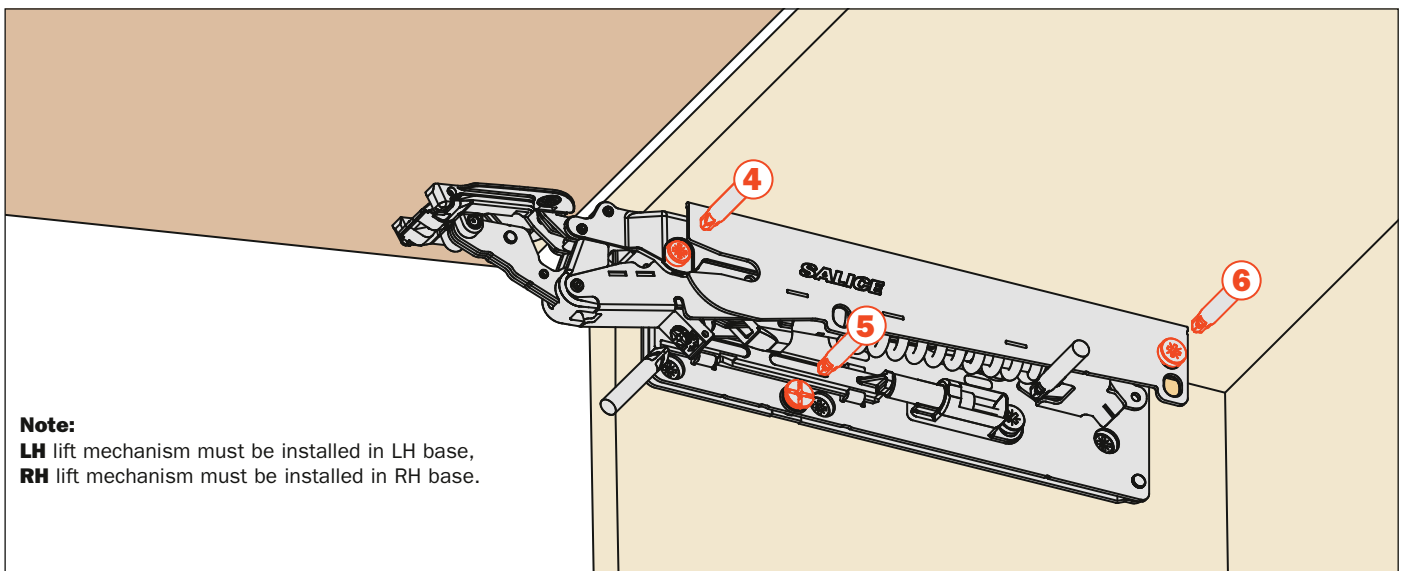
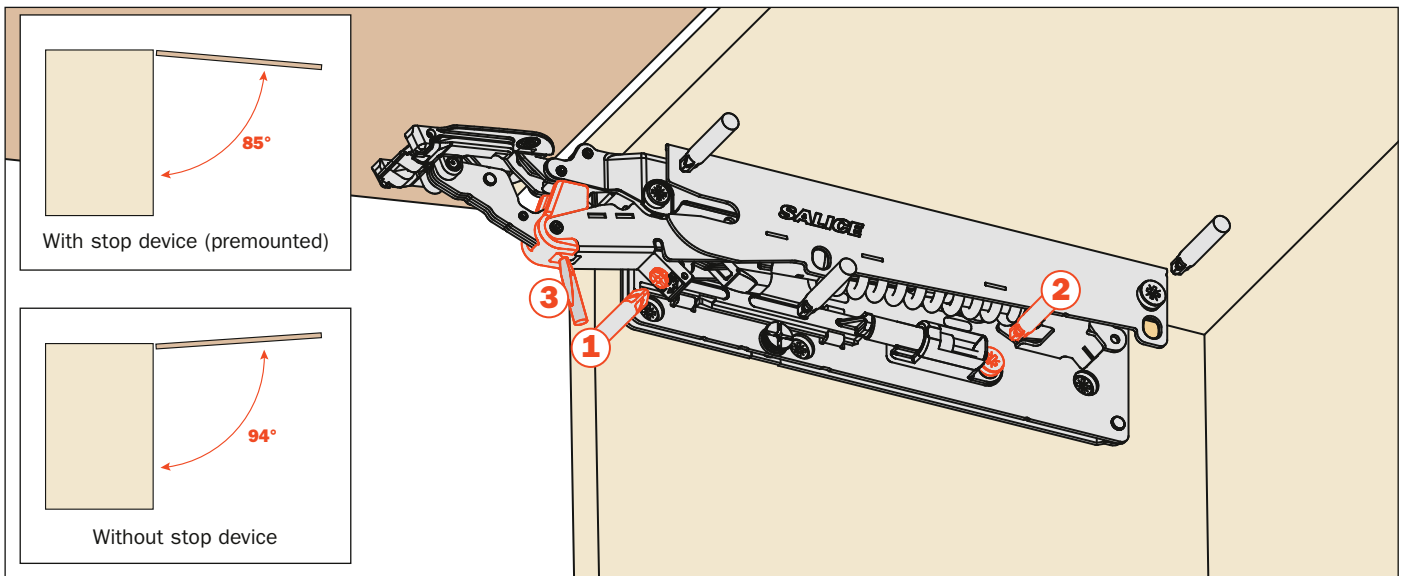

Removal of the covers

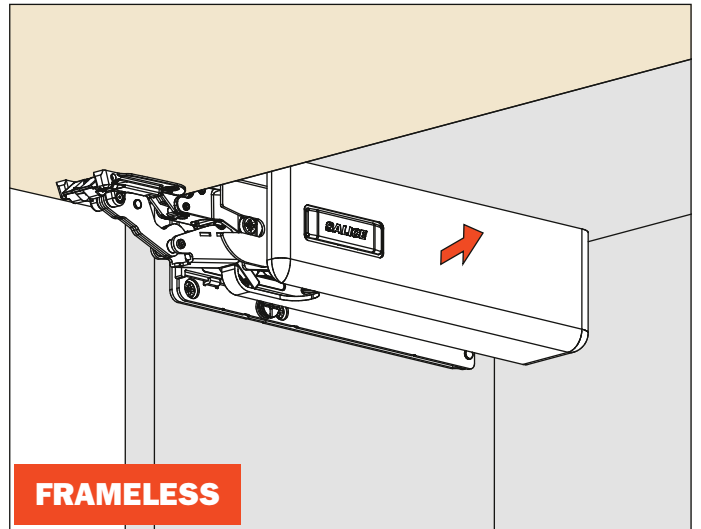
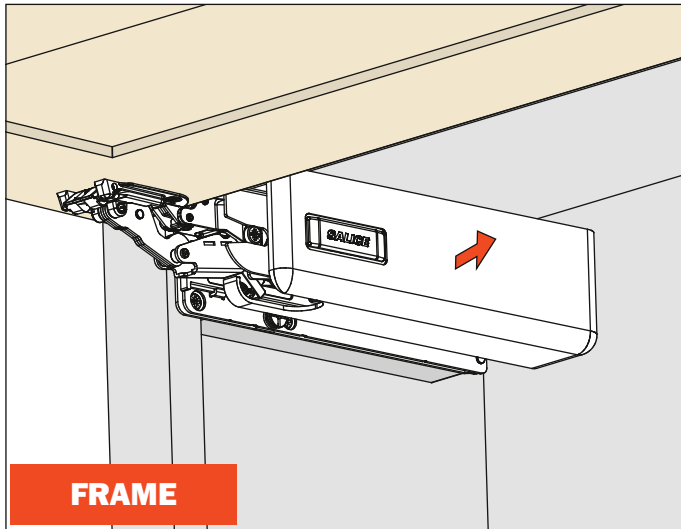

Disassembly of the system

Press the back lever and remove the lift mechanism. This operation is tool free.

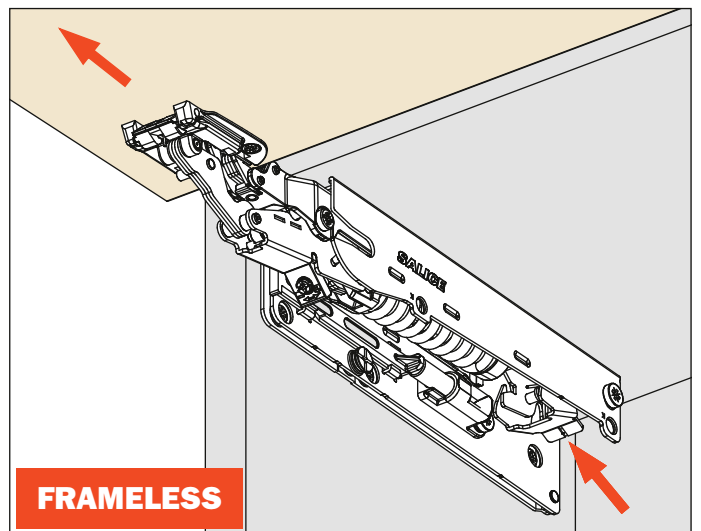
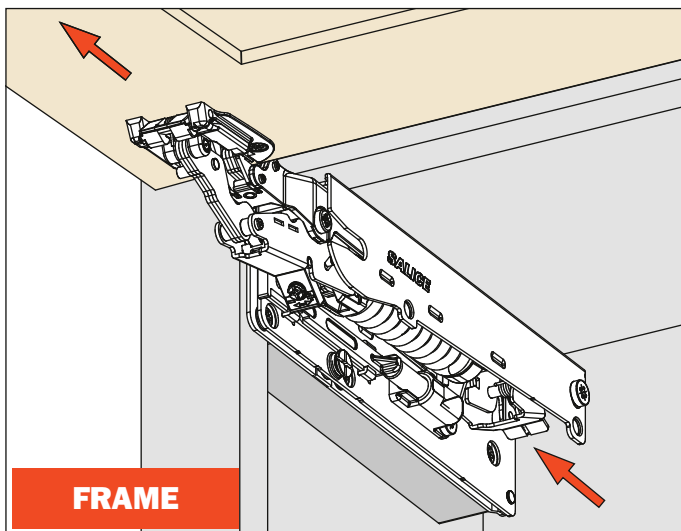

Remove the lift mechanism from the cups (door)

Disconnecting the system from the cups. This operation is tool free.

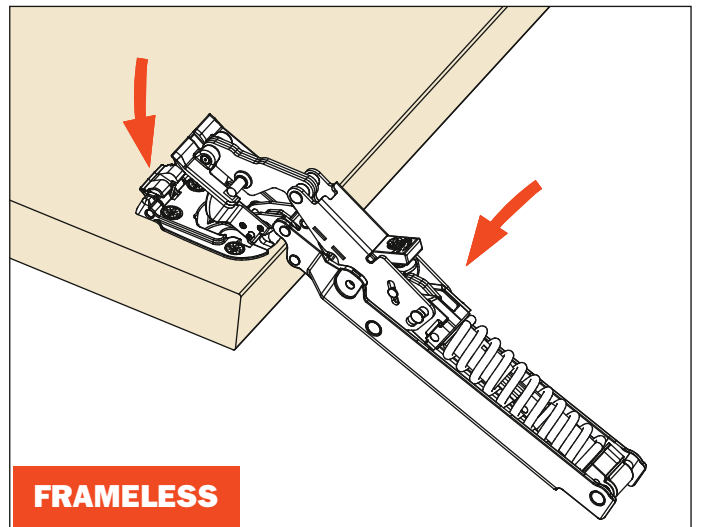
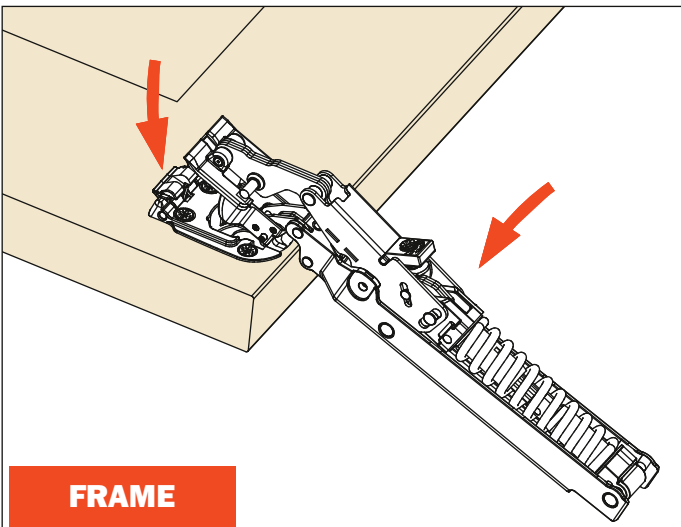

Wind - Optional top mount bracket



Technical information

Bracket to be attached to the top of the cabinet for use with:

- angled cabinets
- wide or heavier doors
- 5 piece doors

Note: When using the top mount bracket, the overlay is reduced by 3mm. Refer to the overlay chart below.

Drilling pattern.

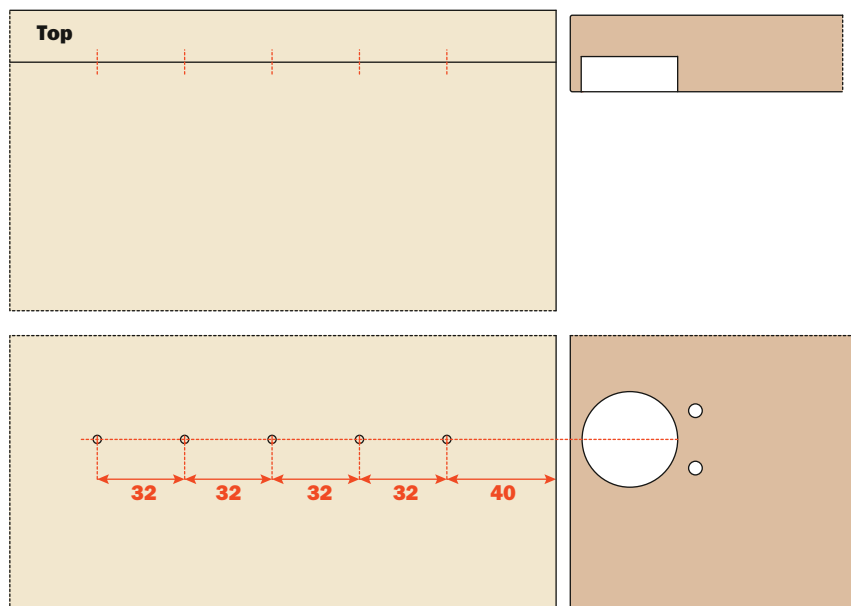

Space needed to open the door.

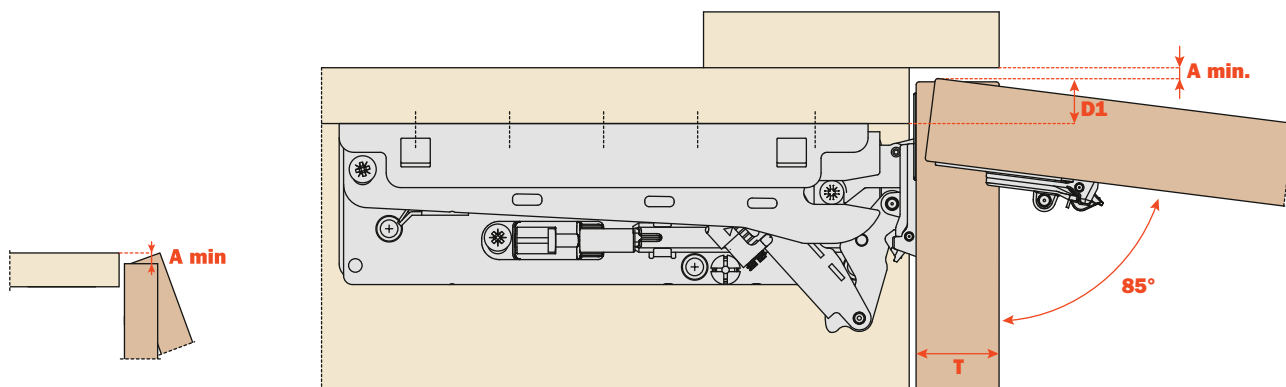

K		D1
3	=	13
4	=	14
5	=	15
6	=	16
7	=	17

	T=	16	17	18	19	20	21	22	23	24	25	26	27	28
K=3	A = min	0	0.1	0.1	0.2	0.2	0.3	0.5	0.6	0.7	0.9	1.1	1.8	2.7
K=4	A = min	0	0.1	0.1	0.2	0.2	0.3	0.4	0.6	0.7	0.9	1.1	1.3	2.1
K=5	A = min	0	0.1	0.1	0.2	0.2	0.3	0.4	0.6	0.7	0.9	1.1	1.3	1.5
K=6	A = min	0	0.1	0.1	0.2	0.2	0.3	0.4	0.6	0.7	0.9	1.0	1.2	1.5
K=7	A = min	0	0.1	0.1	0.2	0.2	0.3	0.4	0.6	0.7	0.8	1.0	1.2	1.4

Assembly instructions for the brackets

Attaching the brackets to the top of the cabinet.

Attach with five #8 x 5/8" wood screws provided

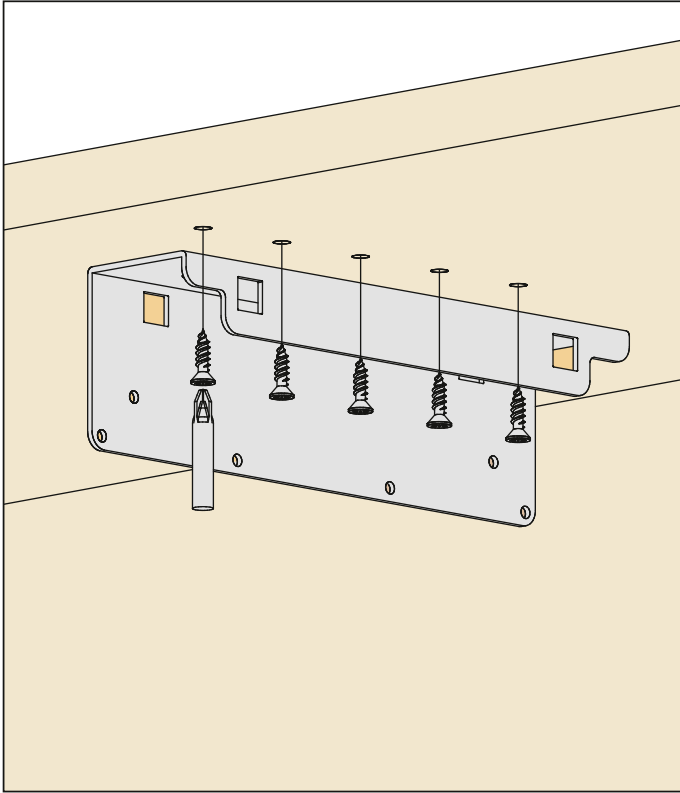

Attaching the base to the top bracket.

Attach with the 3 machine screws provided.

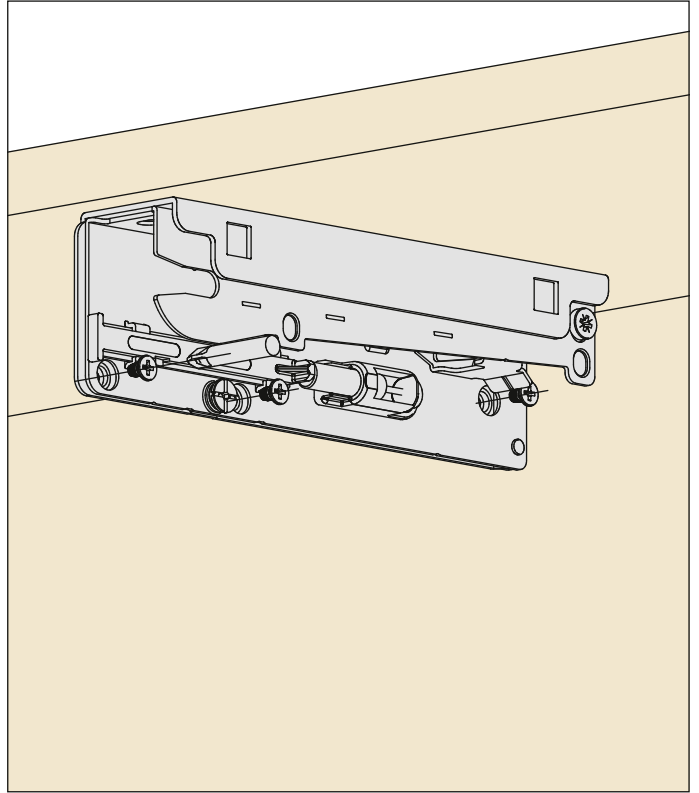

Connecting the lift system to the base.

This operation is tool free.

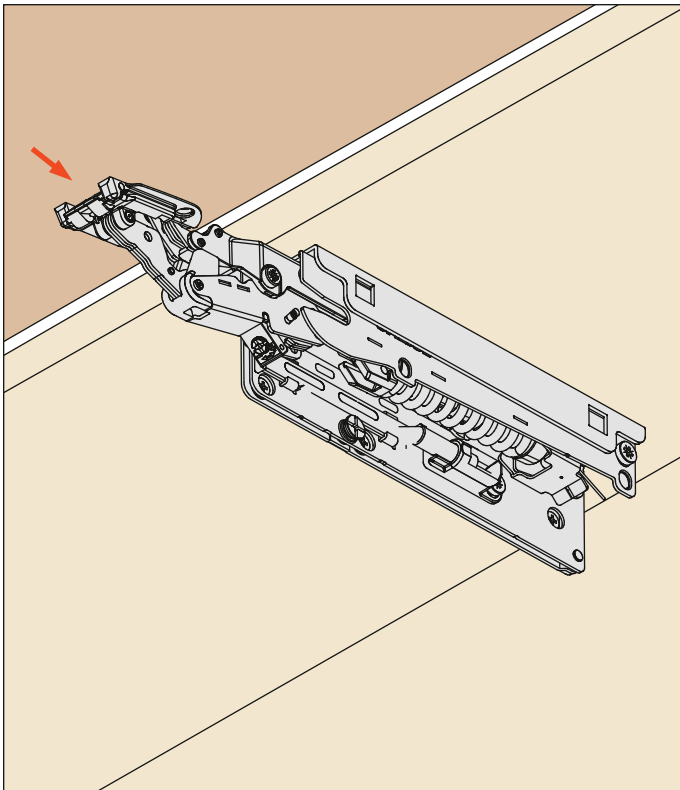

Installing the covers.

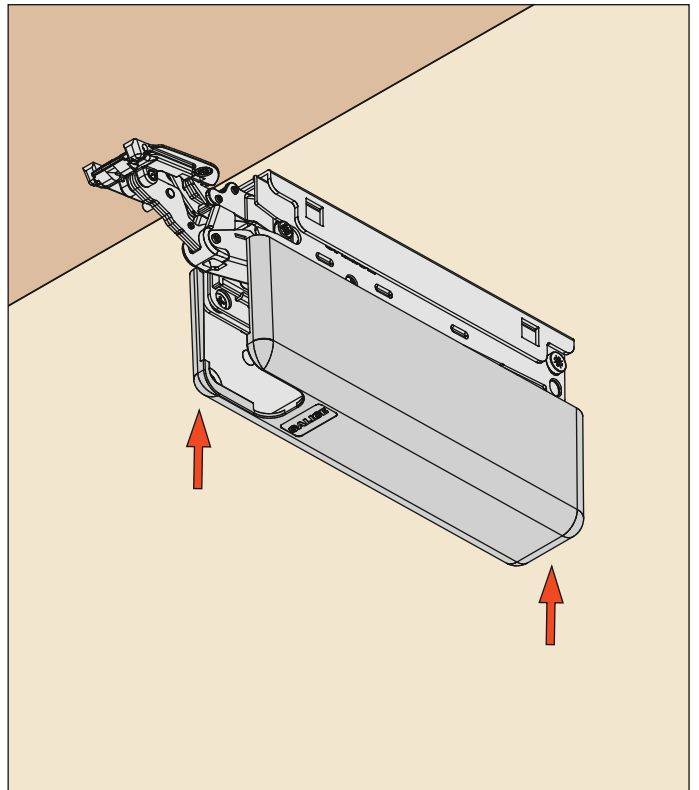

Wind - Disassembly instructions for the top mount brackets

Removal of the covers.

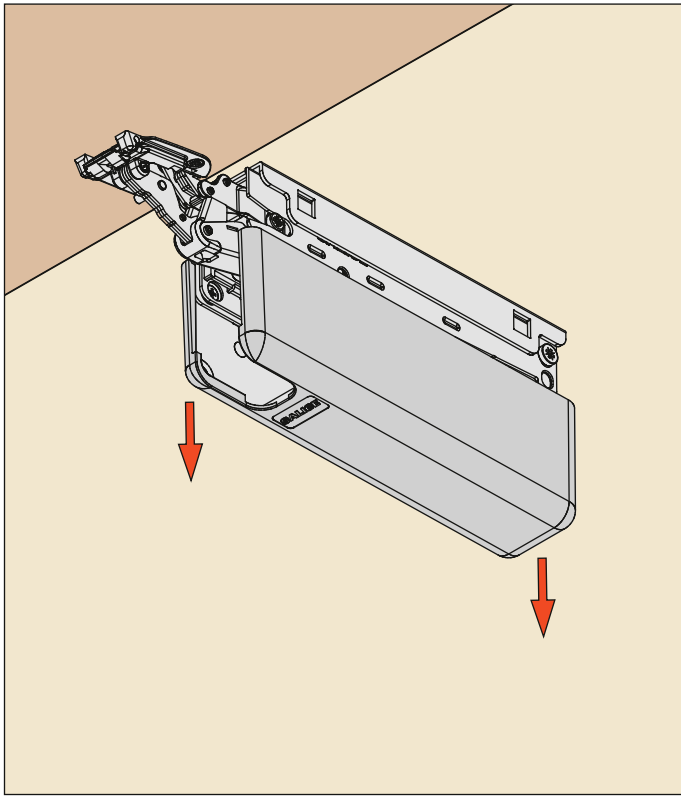

Remove the base from the bracket.

Disassembly of the system.

Press the back lever and remove the lift system.
This operation is tool free.

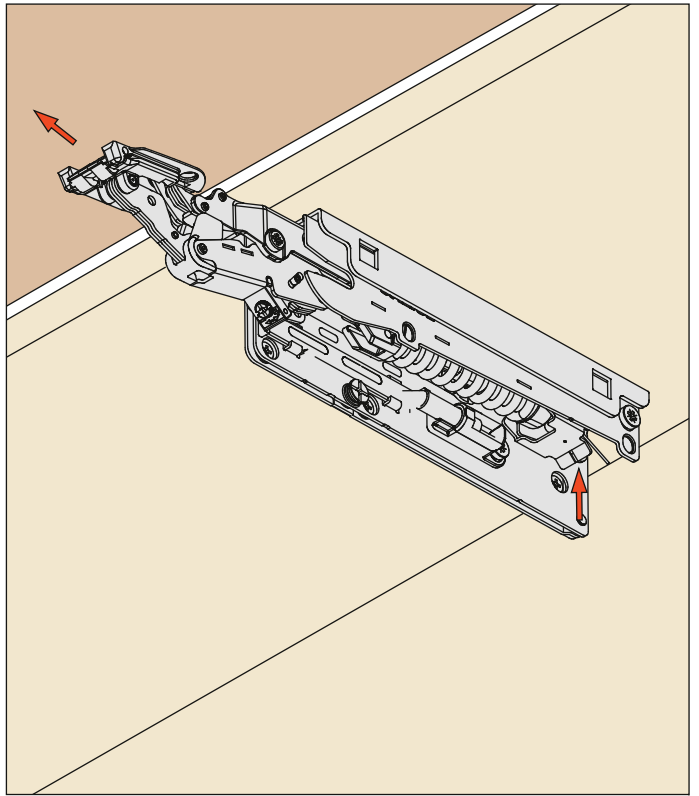

Remove the screws and the bracket.

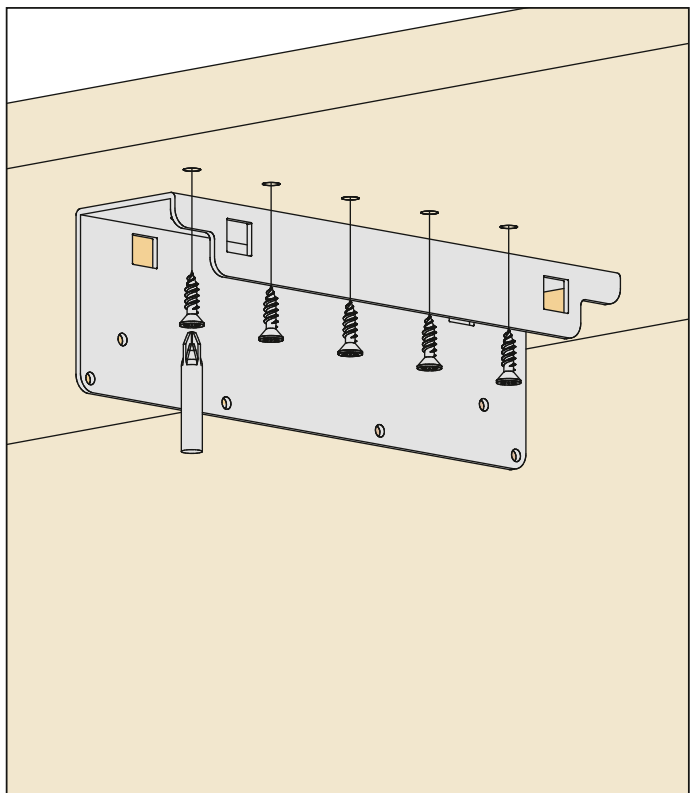
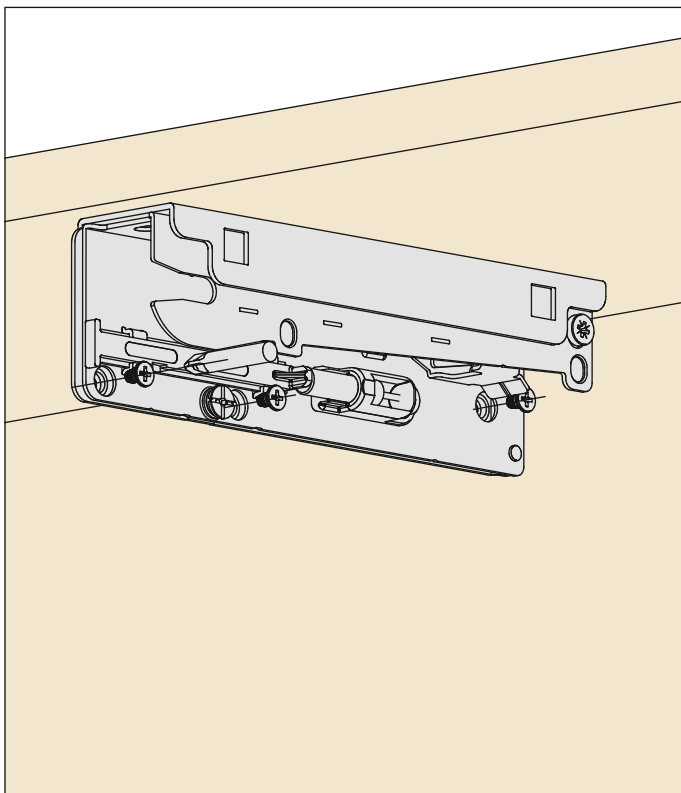

Top mount bracket applications

**For cabinets that require a third system. For wide cabinet applications without a center partition.
The maximum door width for two Wind is 1200mm/48"**

Note: Wind can be used on doors that are larger or heavier by adding additional Wind lifts to the cabinet and door. This can be done by installing a center partition and adding additional Wind lifts or by utilizing the Top Mount Brackets with additional Wind lifts. For all applications requiring more than two Wind lifts, check the Wind charts on pages 19 & 20. Please consult with your local sales representative or contact technical service.

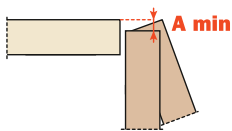
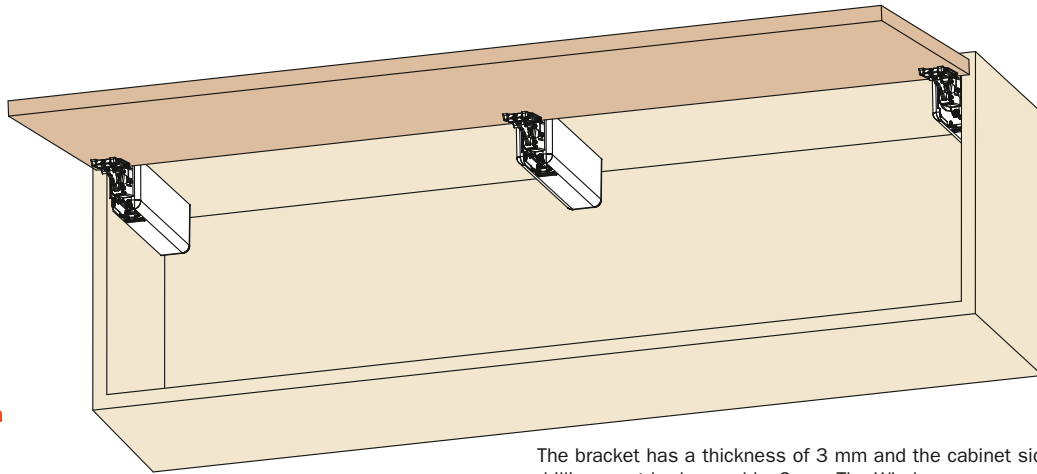

The bracket has a thickness of 3 mm and the cabinet side drilling must be lowered by 3mm. The Wind covers are adjustable and can be positioned to cover the 3mm space at the top.

K		D1
3	=	13
4	=	14
5	=	15
6	=	16
7	=	17

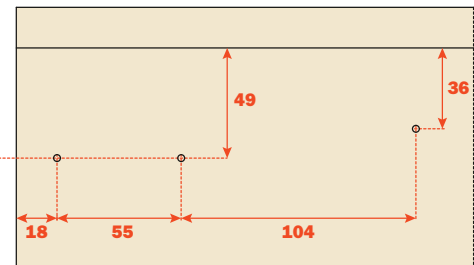
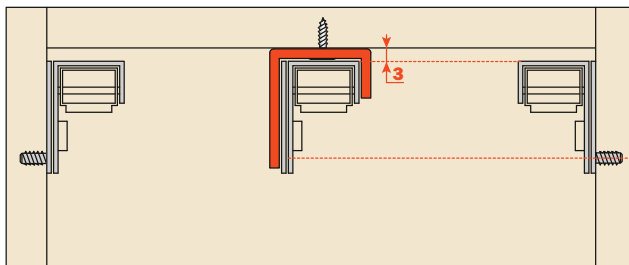

For angled cabinets.

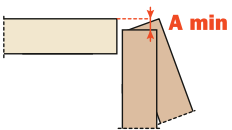
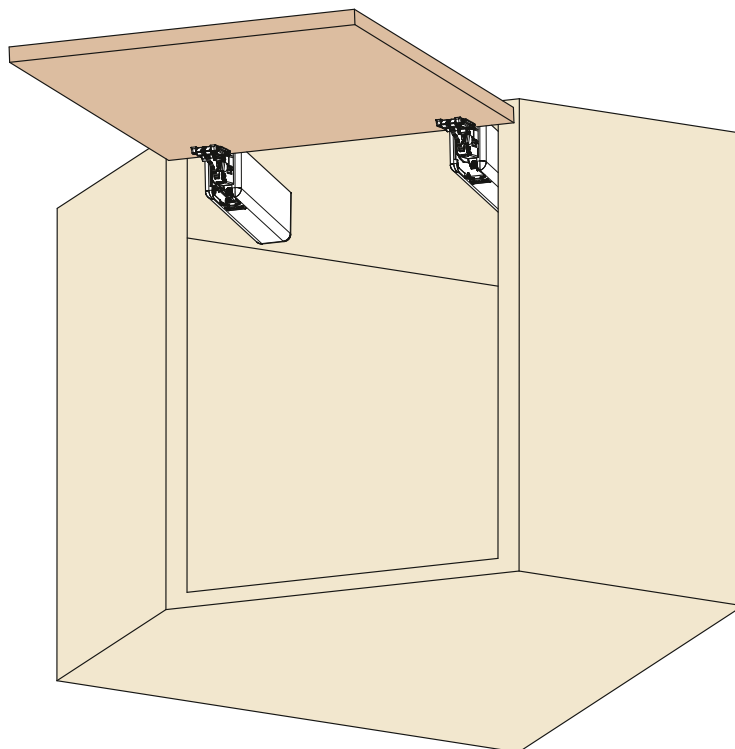

K		D1
3	=	13
4	=	14
5	=	15
6	=	16
7	=	17

Wind - Cover finishes for the cabinet base

SRXA78A1SNXX_

White
Nickel-plated cover cap



SRXA78AQSXXX_

Glossy white
Nickel-plated cover cap



SRXA78AMSXXX_

Gray
Nickel-plated cover cap



SRXA78AISXXX_

Stainless steel
Nickel-plated cover cap



SRXA78A0SNXX_

Satin metal black
Titanium cover cap



SRXA78ANSXXX_

Glossy metal black
Titanium cover cap



SRXA78ACSXXX_

Champagne
Nickel-plated cover cap



Cover finishes for the Top mount bracket

SRUA78A1SNXXI

White



SRUA78AQSXXI

Glossy white



SRUA78AMSXXI

Gray



SRUA78AISXXI

Stainless steel



SRUA78A0SNXXI

Satin metal black



SRUA78ANSXXI

Glossy metal black





SRUA78ACSNXXI

Champagne

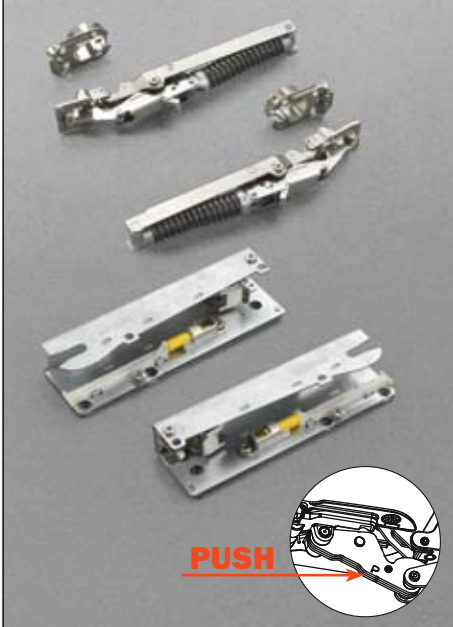

KIT PACKAGING	PART NUMBER	PACKAGING
	<p style="text-align: center;">SOFT CLOSE FRAKFEX SN9 SPRING FORCE ↑</p> <p style="text-align: center;">See page 18 and 19 for the appropriate spring package letter</p>	<p>One box contains:</p> <ul style="list-style-type: none"> 2 hinge cups • 1 Right hand lift mechanism 1 Left hand lift mechanism • 1 Right hand cabinet base 1 Left hand cabinet base • <p>Includes 5mm x 13mm system screws</p> <p>Note : #7 x 5/8" wood screws can also be used</p>
	<p style="text-align: center;">PUSH OPENING FRAKFEP SN9 SPRING FORCE ↑</p> <p style="text-align: center;">See page 18 and 19 for the appropriate spring package letter</p>	

INDUSTRIAL PACKAGING	PART NUMBER	PACKAGING
	<p style="text-align: center;">SOFT CLOSE FRAKINX SN9 SPRING FORCE ↑</p>	<p>One box contains:</p> <ul style="list-style-type: none"> 18 Hinge cups • 9 Right hand lift mechanisms 9 Left hand lift mechanisms • 9 Right hand cabinet bases 9 Left hand cabinet bases • <p>Includes 5mm x 13mm system screws</p> <p>Note : #7 x 5/8" wood screws can also be used</p>
	<p style="text-align: center;">PUSH OPENING FRAKINP SN9 SPRING FORCE ↑</p>	

COVERS	PART NUMBER	PACKAGING
	<p style="text-align: center;">KIT PACKAGING SRXA78A SNXXF COVER COLOR ↑</p> <p style="text-align: center;">See page 14 for the appropriate cover number</p>	<p>One box contains:</p> <ul style="list-style-type: none"> 1 Right hand cover 1 Left hand cover Includes cover caps <p>Note: can be personalized</p>
	<p style="text-align: center;">INDUSTRIAL PACKAGING SRXA78A SNXXI COVER COLOR ↑</p> <p style="text-align: center;">See page 14 for the appropriate cover number</p>	<p>One box contains:</p> <ul style="list-style-type: none"> 9 Right hand covers 9 Left hand covers Includes cover caps <p>Note: can be personalized</p>

KIT-SET PACKING BRACKET AND COVER	PART NUMBER	PACKAGING
	<p style="text-align: center;">FRAUFEXSN_</p> <p style="text-align: center;">  COLOR OF THE COVER </p>	<p>1 carton contains:</p> <ul style="list-style-type: none"> 2 brackets · 2 covers for the brackets · <p>Wood screws to install the bracket and machine screws to attach the base are included.</p>

INDUSTRIAL PACKAGING TOP MOUNT BRACKET	PART NUMBER	PACKAGING
	<p style="text-align: center;">FRAUINXXX5</p>	<p>1 carton contains:</p> <ul style="list-style-type: none"> 18 brackets · <p>Wood screws to install the bracket and machine screws to attach the base are included.</p>

INDUSTRIAL PACKAGING COVER FOR THE BRACKET	PART NUMBER	PACKAGING
	<p style="text-align: center;">SRUA78A_SNXXI</p> <p style="text-align: center;">  COLOR OF THE COVER </p>	<p>1 carton contains:</p> <ul style="list-style-type: none"> 18 covers for the brackets

Wind - Charts and Spring force identification

Use the charts to determine the correct lift mechanism based on the door height and the door weight. When calculating the door weight you must include the weight of the decorative hardware. **The maximum door width for two Wind lifts is 1200mm/48".**

Note: Wind can be used on doors that are larger or heavier by adding additional Wind lifts to the cabinet and door. This can be done by installing a center partition and adding additional Wind lifts or by utilizing the Top Mount Brackets with additional Wind lifts.

For all applications requiring more than two Wind lifts, check the Wind charts on pages 19 & 20. Please consult with your local sales representative or contact technical service.

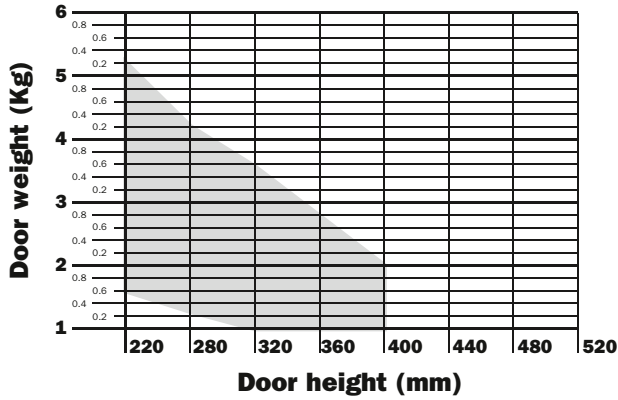

Min door height - 8-5/8"
Max door height - 15-3/4"

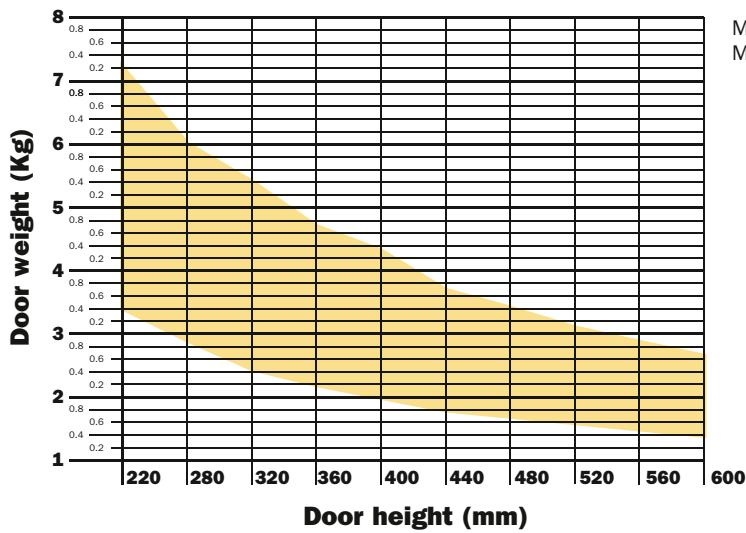
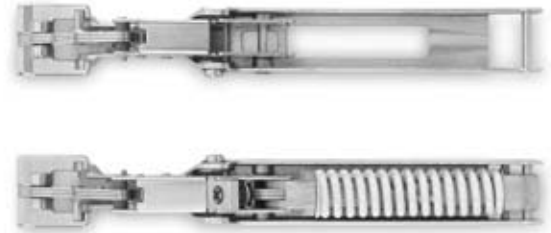
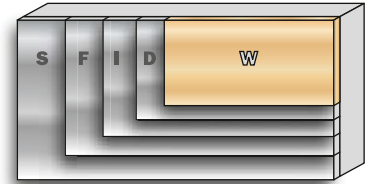

Min door height - 8-5/8"
Max door height - 24"

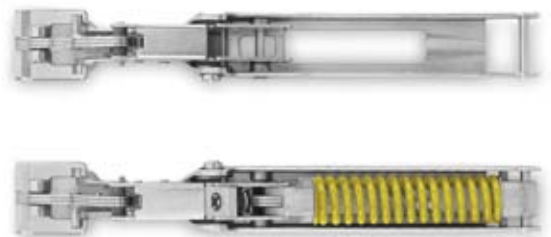
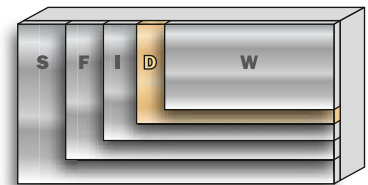

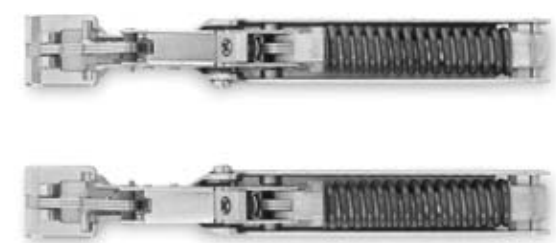
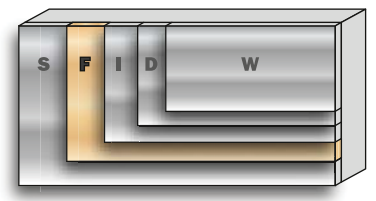
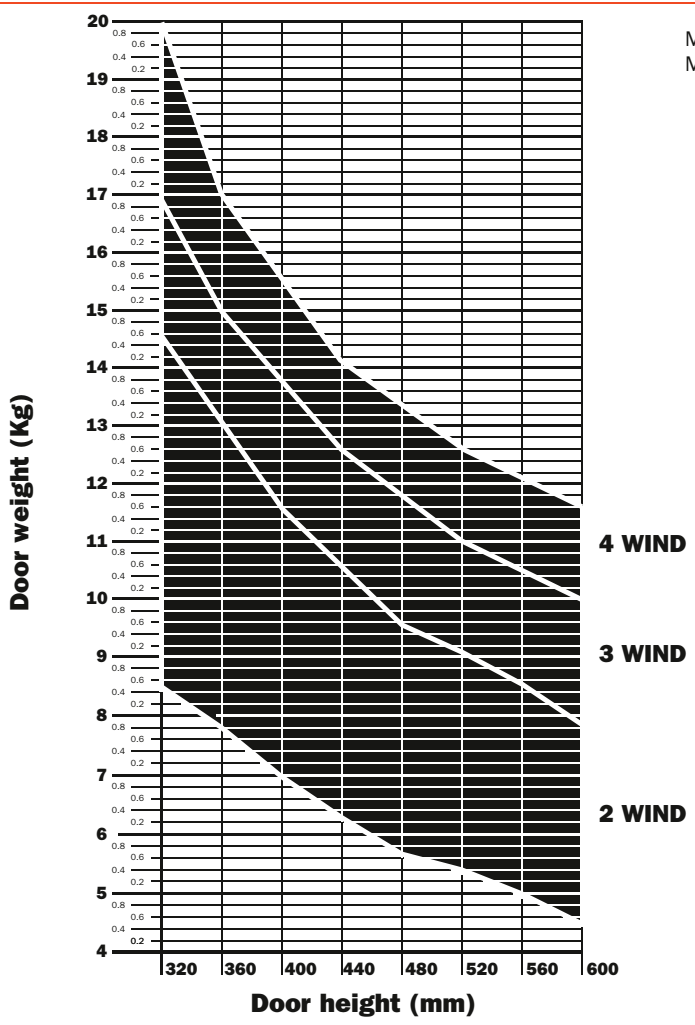
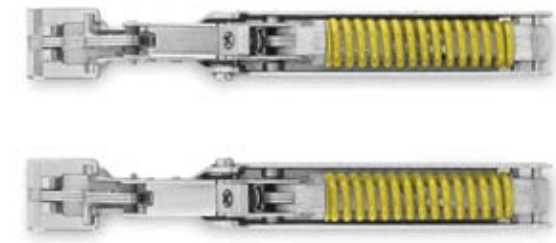
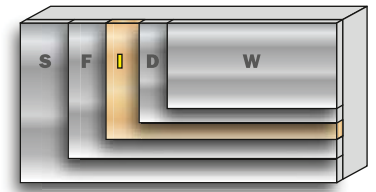
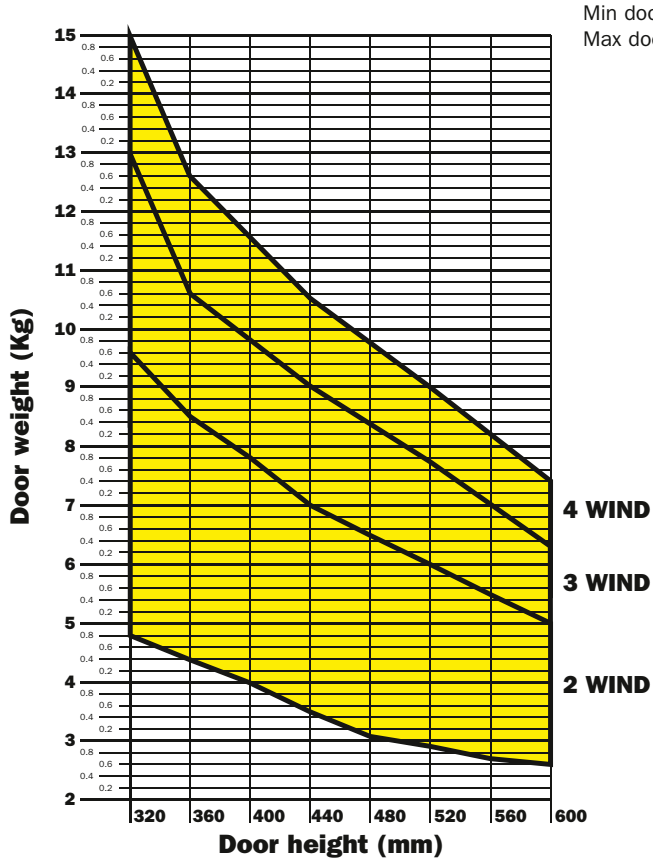

Wind - Charts and Spring force identification

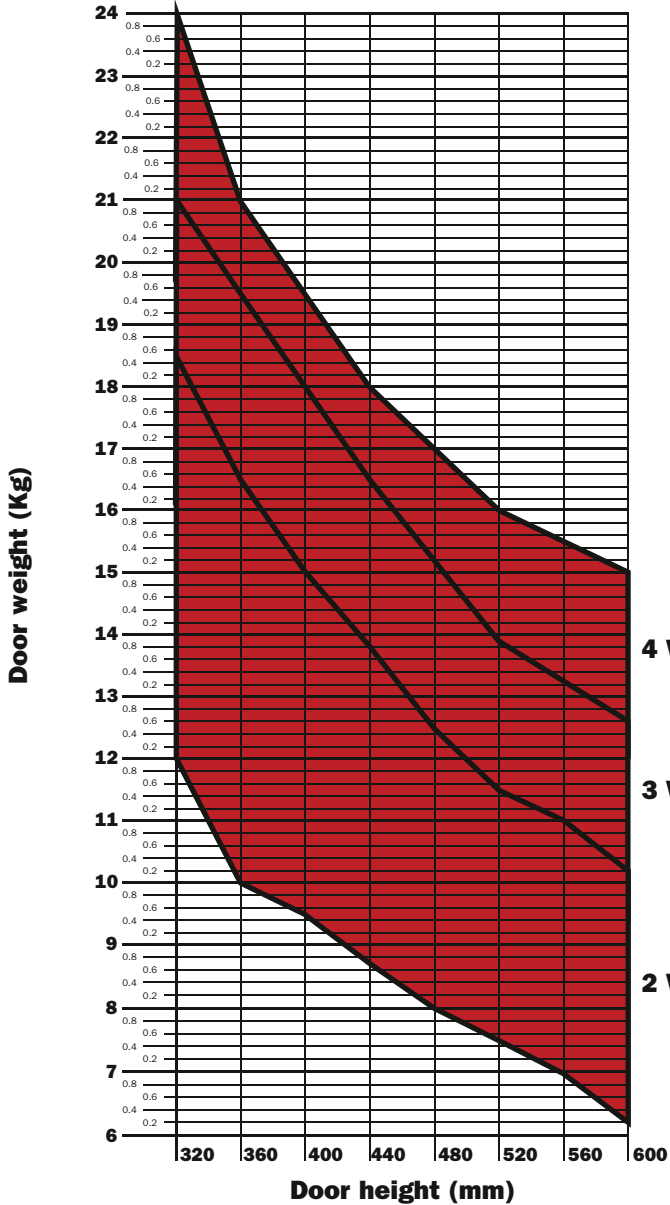

Min door height - 12-9/16"
 Max door height - 24"

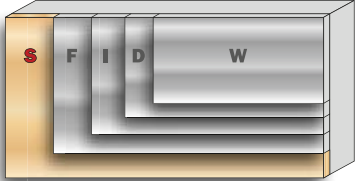

4 WIND

3 WIND

2 WIND

Magnetic Push



Magnetic Push - Release device and retaining catches

DPMSNB - beige



DPMSNG - gray



Release device.
ø 10 mm, 40 mm length.

Packing

Box 250 pieces
Carton 1.500 pieces

DPASNB - beige



DPASNG - gray



Magnetic device to be used to increase the magnetic holding strength. It must always be used together with the DPM. The suggested position of the DPM is the point of pressure on the door. The DPA can be positioned at any point along the opening edge of the door.
ø 10 mm, 40 mm length.

Packing

Box 250 pieces
Carton 1.500 pieces

DP39XXG



Adjustable magnetic catch. Inserted into the door.
ø 15 mm

Packing

Box 250 pieces

DP28SN9



Retaining catch to be inserted with pin.
ø 11.5 mm surface.

Packing

Box 250 pieces

DP38XX91



Retaining catch with adhesive.
20x14 mm surface.

Packing

Box 250 pieces

Release device application

Release / Magnetic device to be inserted

Drill a hole \varnothing 10 mm and min. 40 mm depth in the top, the side or the bottom panel of the cabinet.
Insert the release device into the hole.

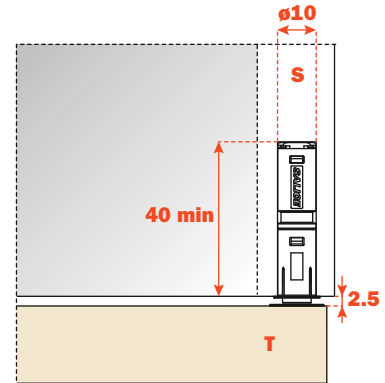

Adjustable magnetic catch

The adjustable catch DP39 is itself magnetic and together with the magnetism of the release device DPM considerably increases the holding strength (30%) of the door against the cabinet side, thus avoiding accidental opening.

For the installation it is necessary to drill a hole \varnothing 15 mm and 11 mm depth in the door.

Depth adjustment from +2.5mm / - 0.5mm

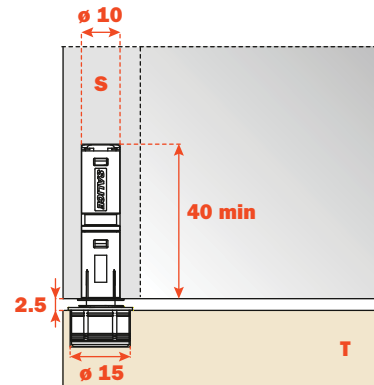

Retaining catch to be inserted

Apply the retaining catch to the magnetic release device.
Close the door.
The point of the retaining catch will show where to insert it.
Reopen the door and press the retaining catch.

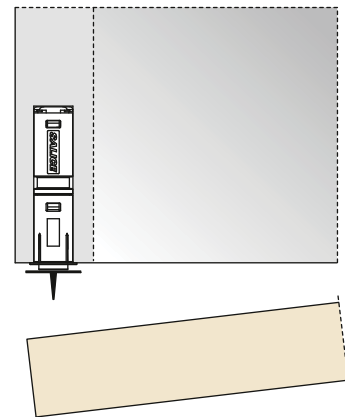

Retaining catch with adhesive strip

Apply the retaining catch to the magnetic release device. Remove the protective strip from the adhesive. Close the door and the retaining catch is positioned on the door.
Reopen the door and apply a firm pressure to the retaining catch to ensure a correct installation.

ATTENTION:

For a correct application and to ensure optimal endurance, we suggest these guidelines are followed:

- 1 - clean and degrease the door surface where the retaining catch is to be installed;
- 2 - remove the protective strip from the adhesive;
- 3 - place the retaining catch in position, in a place that is at room temperature $\geq 10^{\circ}$ (50°F) and apply a firm pressure for 10-15 seconds.

After few seconds from the installation the retaining catch is suitable for the use.
After 24h the max. hold is attained.

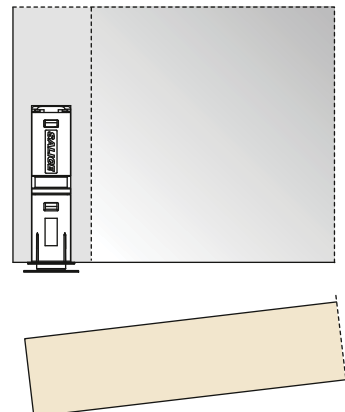

FRAME

Where to apply the Push devices

For cabinet heights 406mm - 610mm (16" - 24")

1 Push device

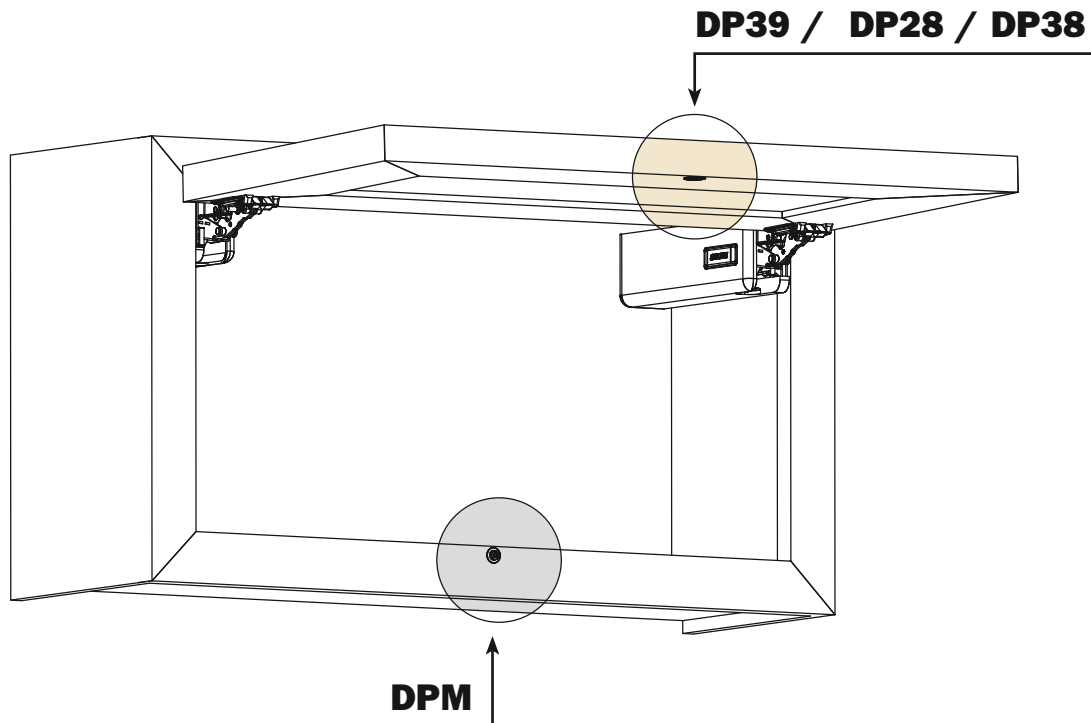

For cabinet heights 220mm - 406mm (8-5/8" - 16")

2 Push devices

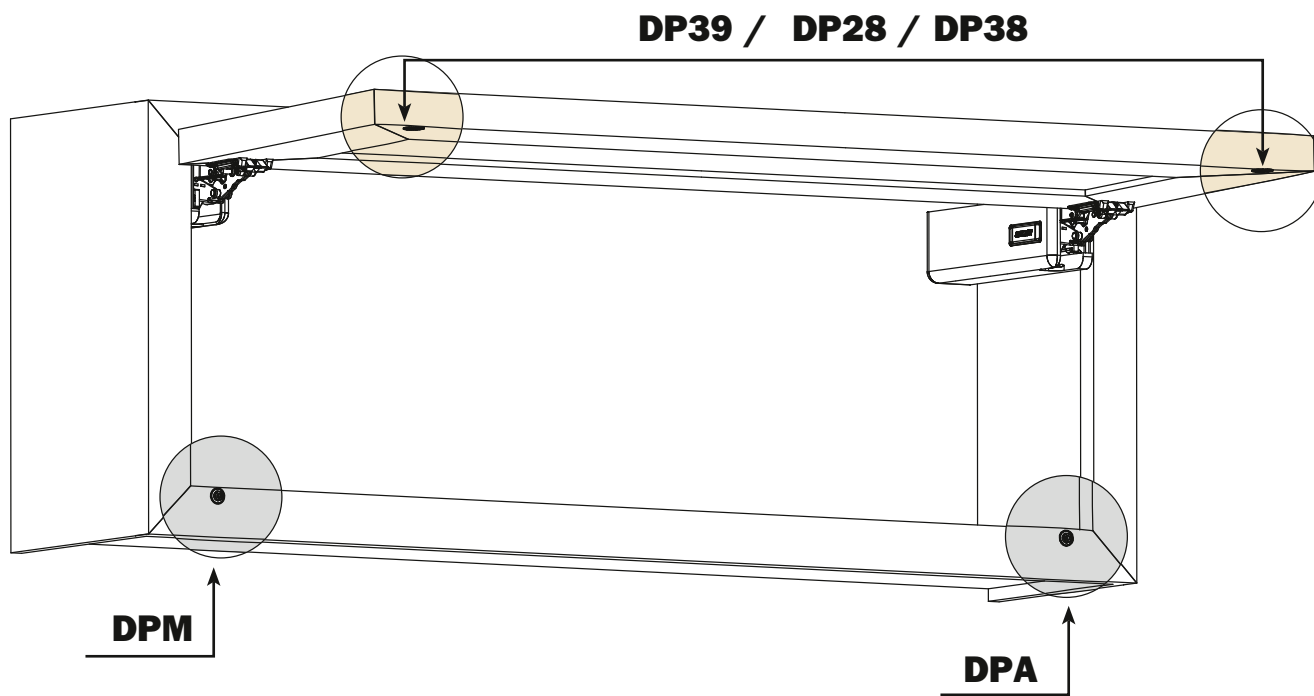

FRAMELESS

Where to apply the Push devices

For cabinet heights 406mm - 610mm (16" - 24")
1 Push device

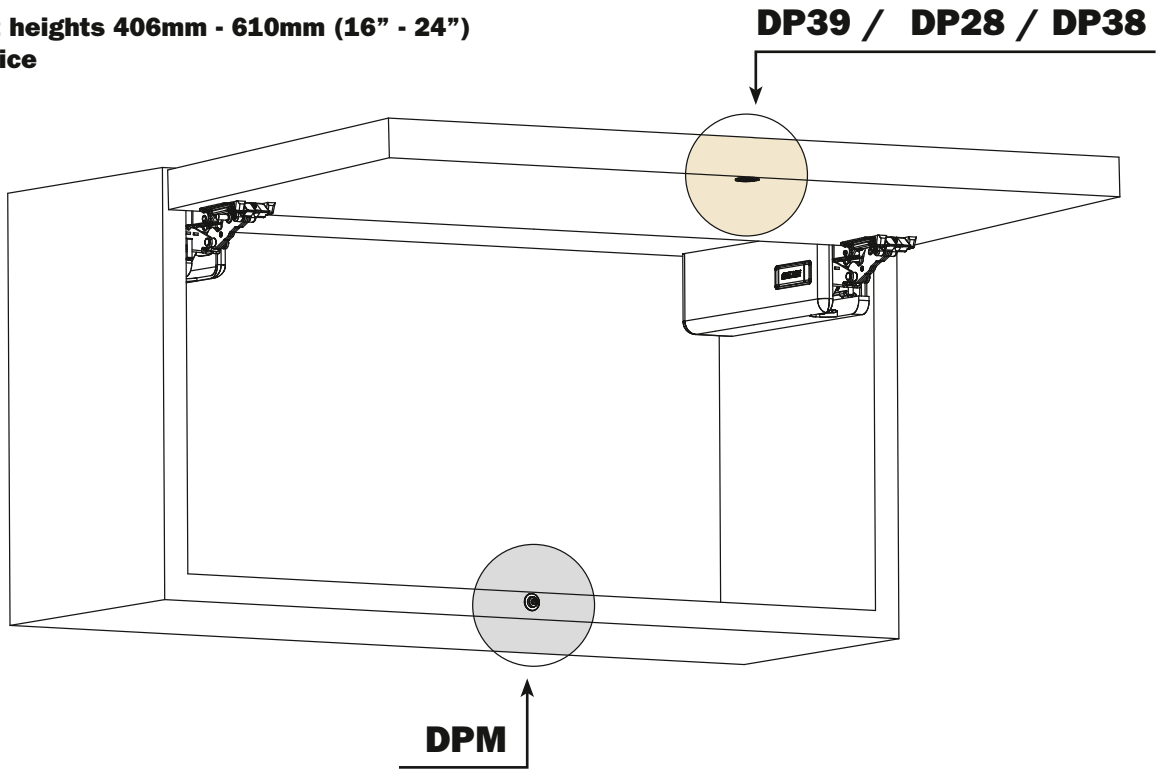

For cabinet heights 220mm - 406mm (8-5/8" - 16")

2 Push devices

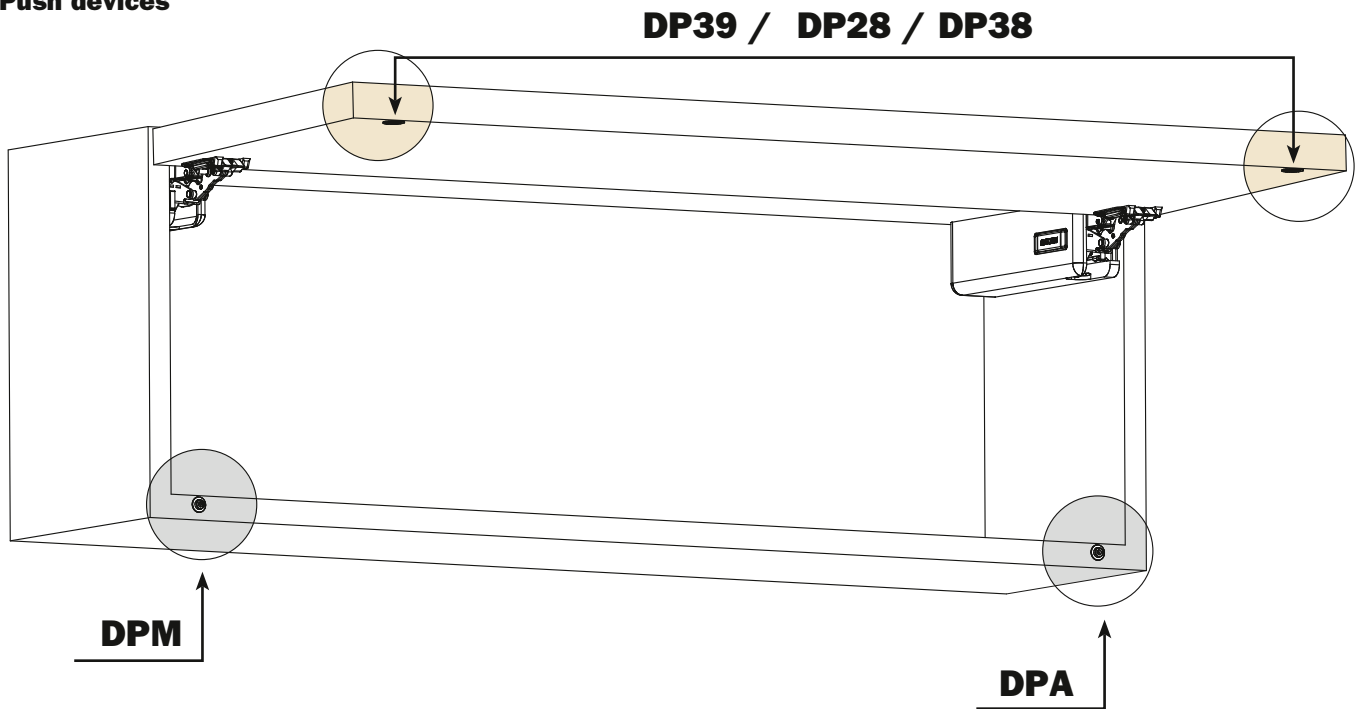

SALICE AMERICA INC.

2123 CROWN CENTRE DRIVE
CHARLOTTE NC. 28227
TEL. 1-800-222-9652
704 8417810
FAX 704 8417808
info.salice@saliceamerica.com
www.saliceamerica.com

SALICE CANADA INC.

4025 SLADEVIEW CRESCENT
UNIT # 7-9
MISSISSAUGA, ONTARIO L5L 5Y1
TEL. 905 8208787
FAX 905 8207226
info.salice@salicecanada.com
www.salicecanada.com



Digital contents:

- **Technical pamphlet in Pdf format**
- **Presentation in Pdf format**
- **Video**

**We reserve the right to change the technical specifications.
Se reserva el derecho de modificar las especificaciones técnicas.**